

„MERCOR S.A.” - Mercor Headquarters
ul. Grzegorza z Sanoka 2
80-408 Gdańsk
tel. +48 58 341 42 45
merc@merc.com.pl

Mercor Tecresa
C/ Margarita Salas nº 6
28919 Leganés (Madrid)
+34 91 428 22 60
+34 91 428 22 62
info@mercortecresa.com

Mercor - Dunamenti Tűzvédelem Zrt.
Nemeskéri Kiss Miklós utca 39
2131 Göd
+36 30 919-0542
godcenter@dunamenti.hu

Mercor-Proof LLC
Krasina 2
123056 Moscow
+7 495 669 05 24
+7 903 743 14 72
info@mercproof.ru

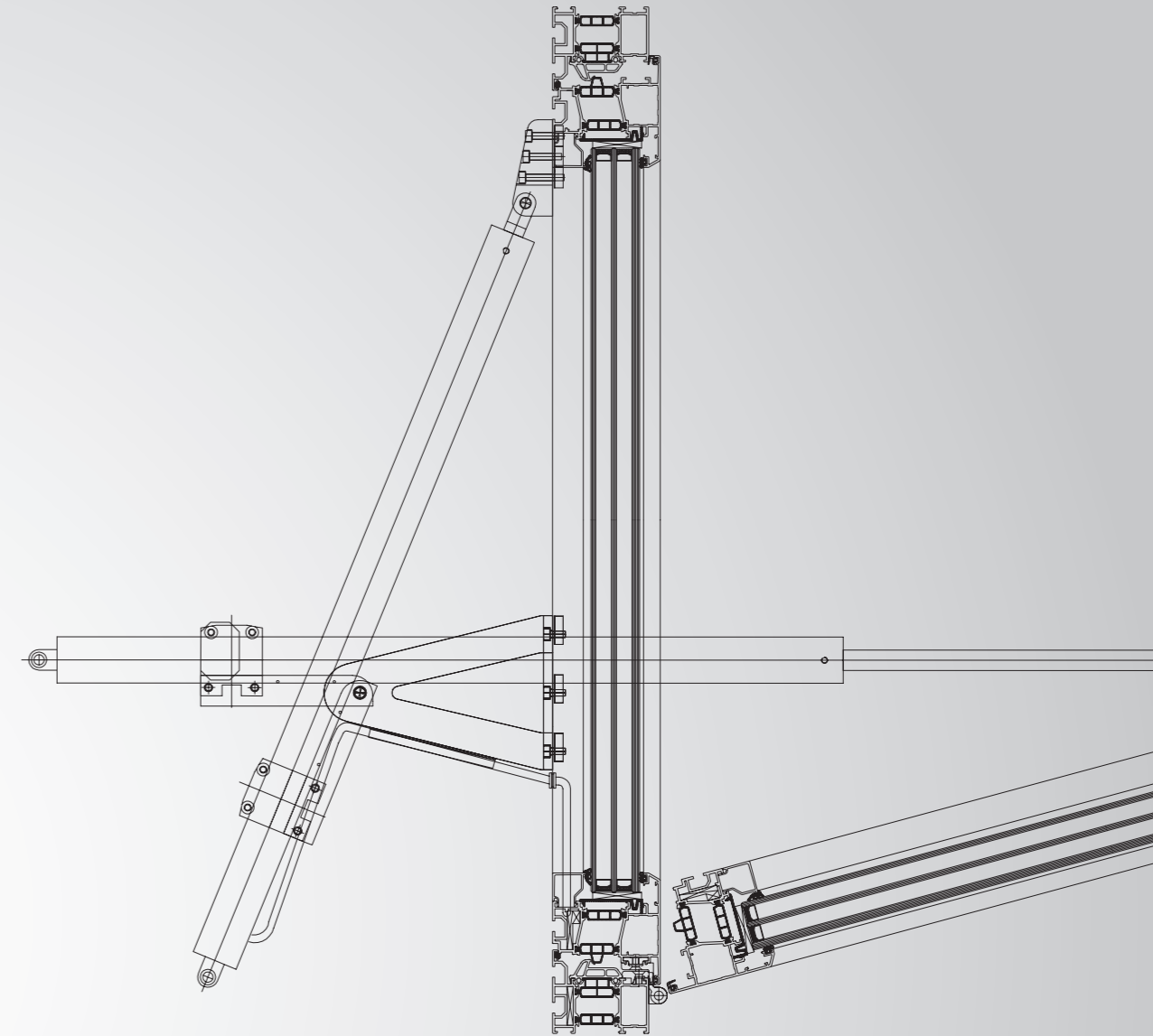
Mercor Fire Protection Systems s.c. S.R.L. Romania
Drum Centura Chitila - Mogosoia, no 3, floor 4
Oras Chitila, Ilfov RO-077045
+40 371 324 182
+40 372 877 070
romania@merc.com.pl

Mercor Ukraina sp. z o.o.
Jaroslawa Mądrego 9B
79016 Lwów
+380 32 240 34 47
+380 32 240 34 07
info@merc.com.ua

Mercor Slovakia
Galvaniho 7/D
821 04 Bratislava
Tel. +421 2 2062 0040
merc@slovakia.sk

Mercor Czech Republic s.r.o.
ul. Zemědělská 5295/6
722 00 Ostrava-Třebovice
tel: +420 597 317 665
e-mail: merc@czech.cz

www.merc.com.pl



TECHNICAL CATALOGUE

WINDOW SMOKE EXHAUST SYSTEMS

mcr OSO Therm 75

Technical Catalogue 2020

Dear Customers,

We are pleased to present you the Technical Catalogue of smoke exhaust systems for the mcr OSO THERM 75 Window Smoke Exhaust System introduced into our offer quite recently. This publication presents the possibilities of this innovative product. The new offering is a combination of our thirty years' experience on the gravitational smoke removal market and specialist knowledge of European experts in the window profile industry.

We believe that the form of presenting our product range will facilitate finding the necessary information about the individual solutions, the included equipment, as well as details on the particular elements of the mcr OSO THERM 75 system.

Every product shipped from "MERCOR" S.A. factories to the customers is meticulously checked in accordance with the highest quality management standards and undergoes a series of approval tests. We are proud to deliver safety through our business.

Contact us today.

MERCOR S.A. Team - Export Department

The electronic version of the Technical Catalogue is available at www.mercor.com.pl



WINDOW SMOKE EXHAUST SYSTEMS

Smoke exhaust, heat removal and roof lighting systems
Technical Catalogue 2020

"MERCOR" S.A. with its registered office in Gdansk reserves the right to introduce any changes to this Technical Catalogue 2020 at any time and without giving any reason. At the same time, the introduction of the changes does not require (at any stage) notifying the users of the Technical Catalogue 2020.

"MERCOR" S.A. reserves that the materials contained in the Technical Catalogue 2020 do not constitute a commercial offer within the meaning of Article 66 of the Civil Code.

Graphic design and computer typesetting:
"MERCOR" S.A. - Gravitational Smoke Removal Department Team

©2020 MERCOR Gdańsk

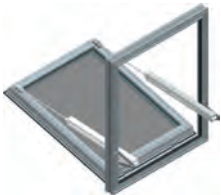

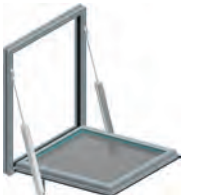
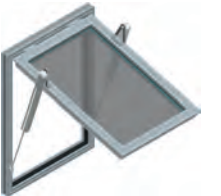
table of contents

| Item. | Product | Page No. |
|-------------------------|---|-----------------|
| mcr OSO THERM 75 | | |
| 1. | mcr OSO THERM 75 5 EXHAUST WINDOWS | 5 |
| 1.1. | outward-opening smoke exhaust windows | 6 |
| 1.1.1. | description of standard | 6 |
| 1.1.2. | non-standard options | 6 |
| 1.1.3. | types of outward-opening smoke exhaust windows | 7 |
| 1.1.4. | technical drawings of smoke exhaust windows | 10 |
| 1.1.5. | technical specification | 14 |
| 1.1.6. | technical specification - application of electro-lock in windows with spindle actuators | 40 |
| 1.2. | inward-opening smoke exhaust windows | 41 |
| 1.2.1. | description of standard | 41 |
| 1.2.2. | non-standard options | 41 |
| 1.2.3. | types of inward-opening smoke exhaust windows | 42 |
| 1.2.4. | technical drawings of smoke exhaust windows | 45 |
| 1.2.5. | technical specification | 49 |
| 1.2.6. | technical specification - application of electro-lock in windows with spindle actuators | 72 |
| 2. | ELECTRIC CONTROL SYSTEM FOR SMOKE EXHAUST WINDOWS | 73 |
| 2.1. | 24V- spindle electric actuators | 74 |
| 2.1.1. | type G spindle electric actuators | 74 |
| 2.1.2. | type S spindle electric actuators | 76 |
| 2.2. | 24V- / 48V- electric chain actuators | 78 |
| 2.2.1. | type KR10B (24V-) electric chain actuators | 78 |
| 2.2.2. | type HCV (24V- / 48V-) electric chain actuators | 79 |
| 2.3. | type HCVA (~230 V-) electric chain actuators | 80 |
| 3. | INSTALLATION OF SMOKE EXHAUST WINDOW | 81 |



1. smoke exhaust windows

Smoke exhaust windows are part of the smoke exhausting system designed to remove fumes, fire gases and heat energy outside the building. They may also serve aeration and daily ventilation function, and thanks to their design, patented technical solutions and finishing, they are part of the building's architecture.

| PARAMETERS | | OUTWARD-OPENING WINDOWS | | INWARD-OPENING WINDOWS | |
|------------------------|--|--|--|---|---|
| | | BOTTOM HUNG | TOP-HUNG | BOTTOM HUNG | TOP-HUNG |
| | |  |  |  |  |
| PRODUCT CLASSIFICATION | Certificate of constancy of performance 1396-CPR-0128 (according to EN 12101-2:2003) | <ul style="list-style-type: none"> - Re1000 - operational reliability during 1000 cycles of opening and closing to smoke exhaust position, and 10 000 cycles to ventilation position (double function window) - WL1000 / WL1250 / WL1500 - operational certainty of window under wind stress equivalent to 1500 Pa, 1200 Pa or 1000 Pa (depending on type, size and accessories), - T(00) - resistance of windows to low temperature 0°C - B300 - resistance of windows to high temperature 300°C - SLO - operational certainty of vents under snow load 0 N/m² | | | |
| | Opening angle | 10° - 90° | | | |
| CONTROL | Electric 24V - (smoke exhausting and daily ventilation) | • | • | • | • |
| | Electric 48V - (smoke exhausting and daily ventilation) | • | • | • | • |
| | Electric 230V - (daily ventilation) | • | • | • | • |
| GLAZING | Triple glass 4/18/4/18/4 Ug=0,5 W/(m ² K) | • | • | • | • |
| | Triple safety glass 4/18/4/18/33.1 Ug=0,5 W/(m ² K) | • | • | • | • |
| | Double safety glass 4/16/33.1 Ug= 1,1 W/(m ² K) | • | • | • | • |
| | Sandwich panel (ALU-PIR-ALU) Ug=0,66 W/(m ² K) | • | • | • | • |

1.1. outward-opening smoke exhaust windows

1.1.1. description of the standard

- classification according to the Certificate of Constancy of Performance No 1396-CPR-0128 (according to EN 12101-2:2003)
- outward-opening smoke exhaust windows for installation in facades as individual smoke exhaust and daily ventilation devices or integrated into post and beam facade systems available on the market
- size range of outward-opening smoke exhaust windows in horizontal arrangement 800x800 mm ÷ 2700x1300 mm, in vertical arrangement 800x800 mm ÷ 1600x2200 mm
- smoke exhaust windows made of custom-designed multi-chamber aluminium profiles with polyamide thermal breaks
- profile width: frame 75 mm and leaf 84 mm
- system of grooves in the profile of the leaf and frame with a covering profile allows to route cables and easily install actuator consoles
- leaf glazing: triple glass 4/18/4/18/4 (heat transfer coefficient $U_g=0.5W / (m^2K)$), triple safety glass 4/18/4/18/33.1 ($U_g=0.5W / (m^2K)$), double glass 4/16/33.1 ($U_g=1.1W / (m^2K)$) or sandwich panel (ALU-PIR-ALU) ($U_g=0.66W / (m^2K)$)
- windows joined with each other by means of vertical or horizontal connection sets
- leaf opening angle $10^\circ \div 90^\circ$ (depending on the size of the window and type of control used)
- exhaust or daily ventilation control: 24 V- / 48 V- power supply (G / S spindle actuators, KR10B / HCV chain actuators) or 230 V~ (HCVA chain actuators)
- use of an electro-lock with interface for the selected dimensional range of smoke exhaust windows with spindle actuators (see page 40 for table of dimensions with electro-lock)

1.1.2. non-standard options

- possibility of making intermediate dimensions of smoke exhaust windows between the values given in the table on pages 15-39; the active aerodynamic area value for these dimensions is calculated by linear interpolation method
- possibility of painting profiles any RAL standard colour; structural or wood imitation colour
- possibility of making bi-colour windows
- glazing beads available in rectangular or rounded versions
- decorative bars referring to the style of old architecture as well as a modern element of architecture:
 - stuck on - glued to the glazing unit both inside and outside
 - internal - placed inside the glazing unit
- glazing bars - dividing the glass into many smaller formats

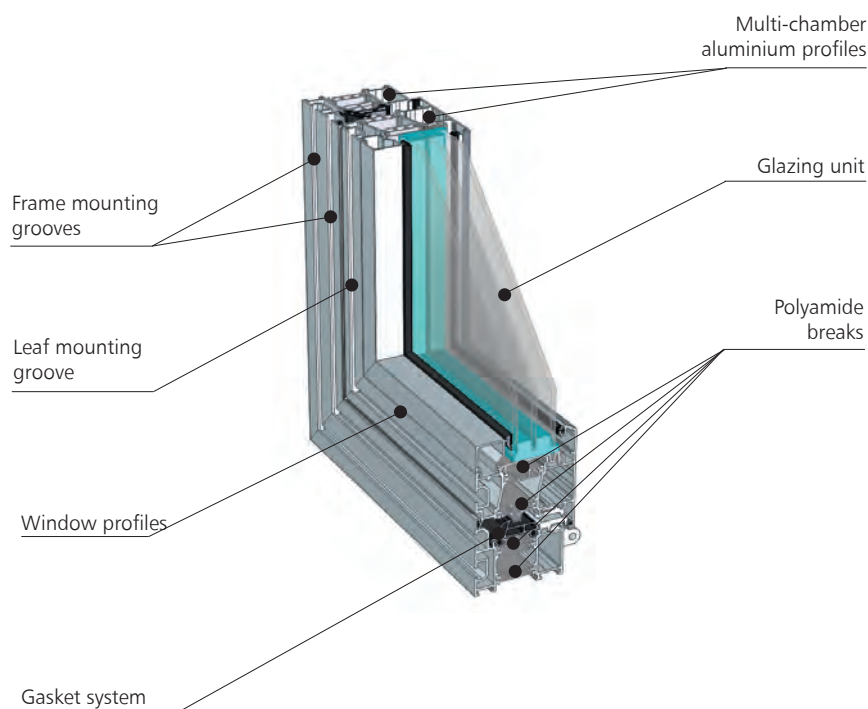


Fig. 1 – Cross-section through the profile of an outward-opening smoke exhaust window

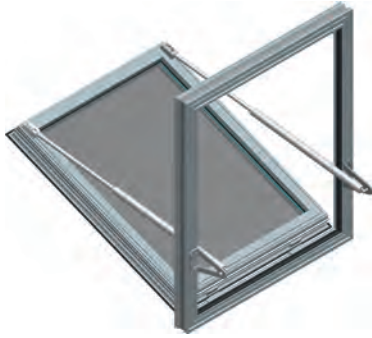
1.1.3. types of outward-opening smoke exhaust windows**bottom hung outward-opening windows**

Fig. 2 - mcr OSO THERM 75 smoke exhaust window with two S spindle actuators



Fig. 3 - mcr OSO THERM 75 smoke exhaust window with two G spindle actuators



Fig. 4 - mcr OSO THERM 75 smoke exhaust window with KR10B / HCV chain actuator



Fig. 5 - mcr OSO THERM 75 smoke exhaust window with two S spindle actuators with shifted pivot point



Fig. 6 - mcr OSO THERM 75 smoke exhaust window with two G spindle actuators with shifted pivot point



Fig. 7 - mcr OSO THERM 75 smoke exhaust window with two KR10B / HCV chain actuators

top-hung outward-opening windows

Fig. 8 - mcr OSO THERM 75 smoke exhaust window with two S spindle actuators



Fig. 9 - mcr OSO THERM 75 smoke exhaust window with two G spindle actuators

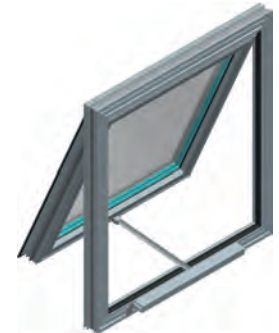


Fig. 10 - mcr OSO THERM 75 smoke exhaust window with KR10B / HCV chain actuator

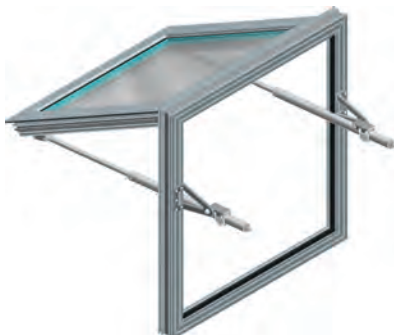


Fig. 11 - mcr OSO THERM 75 smoke exhaust window with two S spindle actuators with shifted pivot point

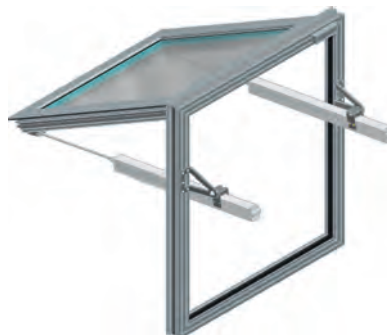


Fig. 12 - mcr OSO THERM 75 smoke exhaust window with two G spindle actuators with shifted pivot point



Fig. 13 - mcr OSO THERM 75 smoke exhaust window with two KR10B / HCV chain actuators

1.1.3.1. design of outward-opening smoke exhaust window with spindle actuators

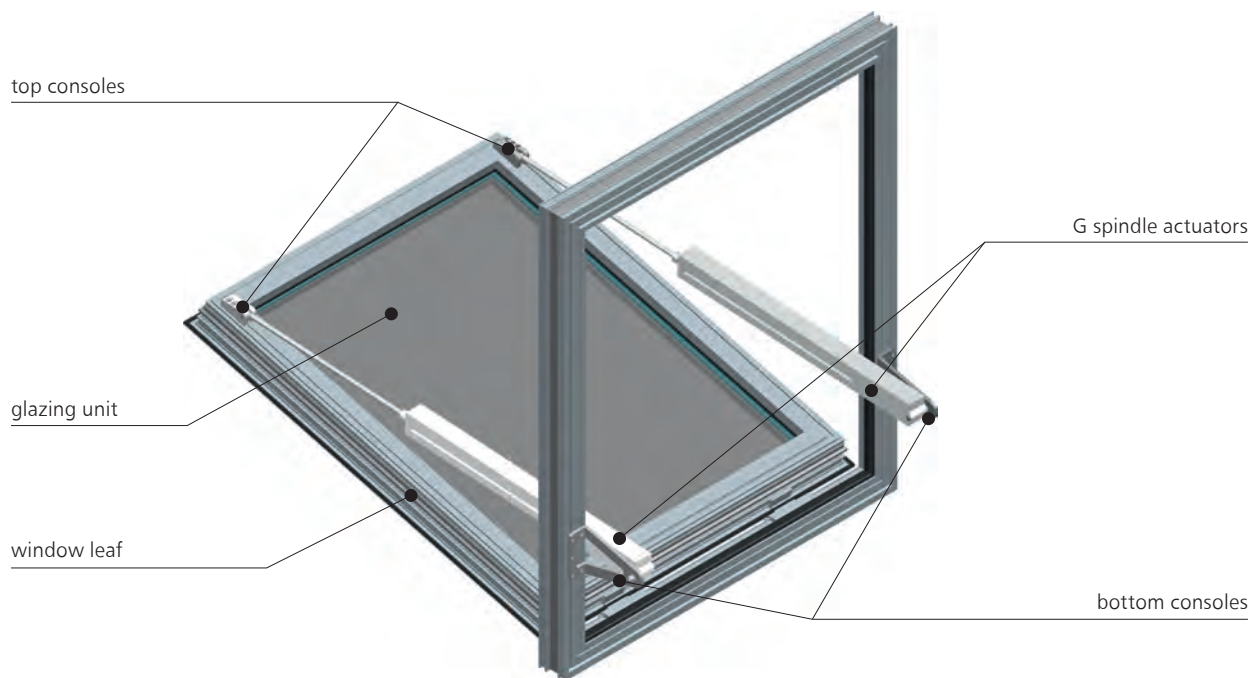


Fig.14 - mcr OSO THERM 75 smoke exhaust window opening outwards by means of two G spindle actuators

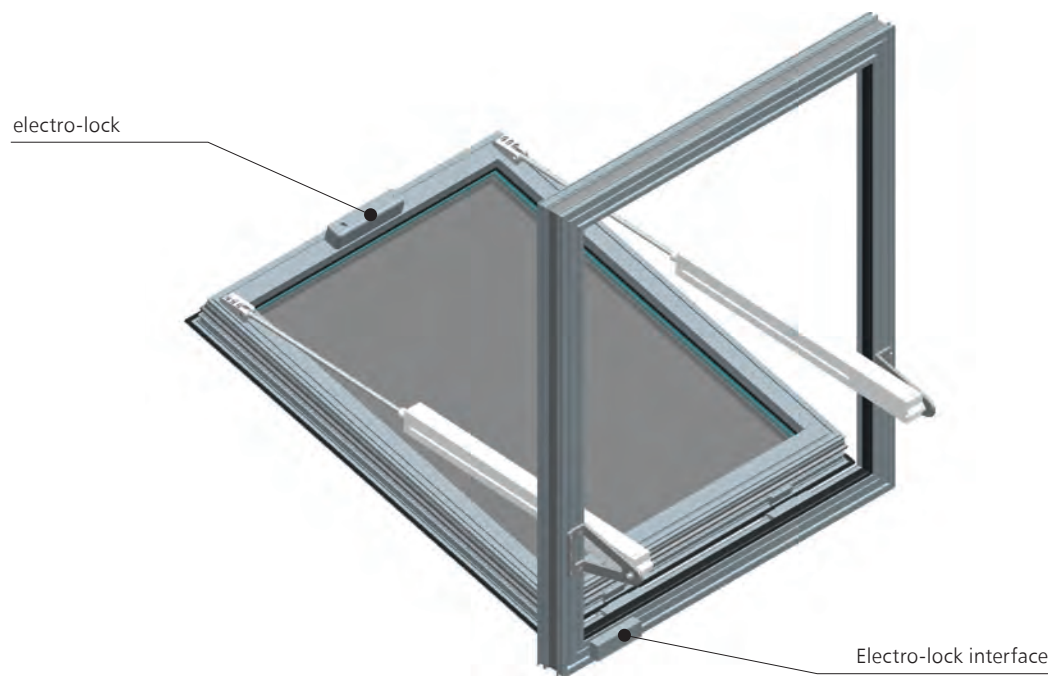


Fig.15 - mcr OSO THERM 75 smoke exhaust window opening outwards by means of two G spindle actuators with electro-lock and interface

1.1.3.2. design of outward-opening smoke exhaust window with chain actuators

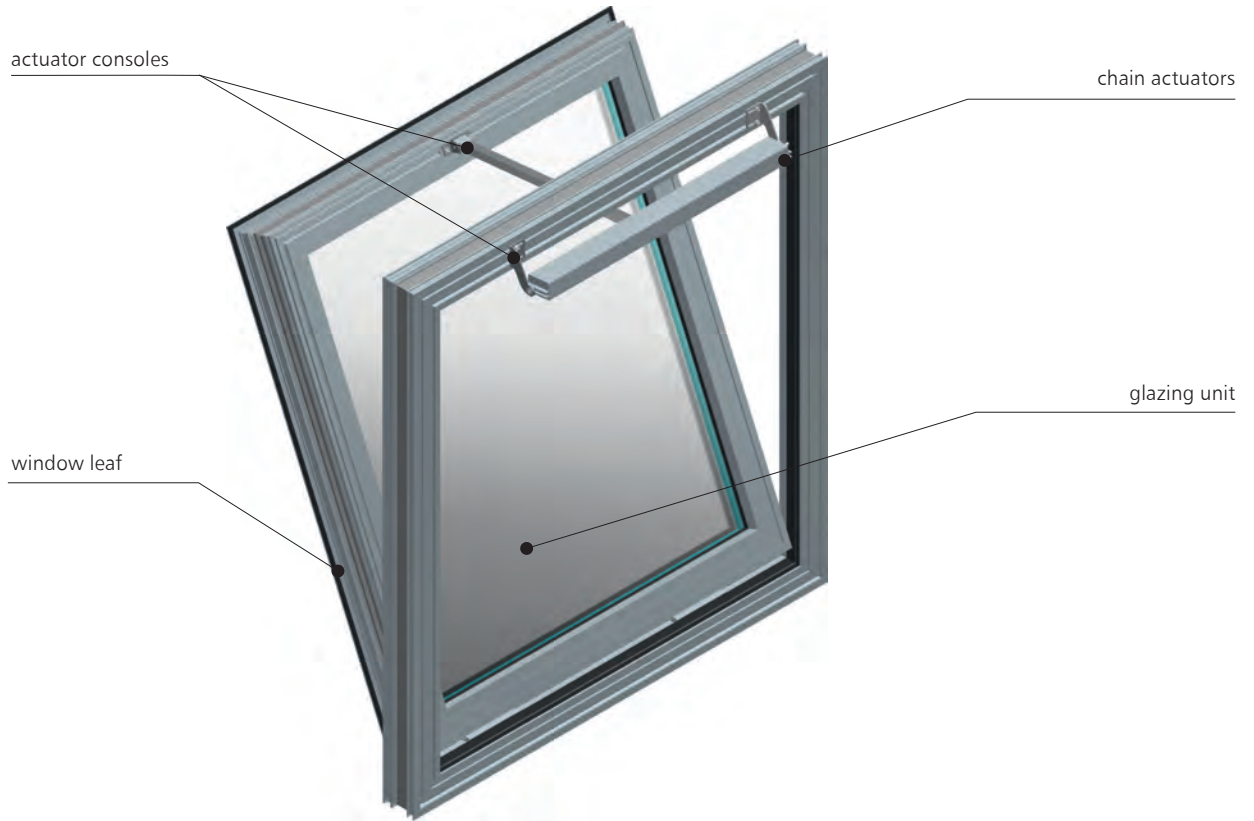


Fig. 16 - mcr OSO THERM 75 smoke exhaust window opening outwards by means of single chain actuator

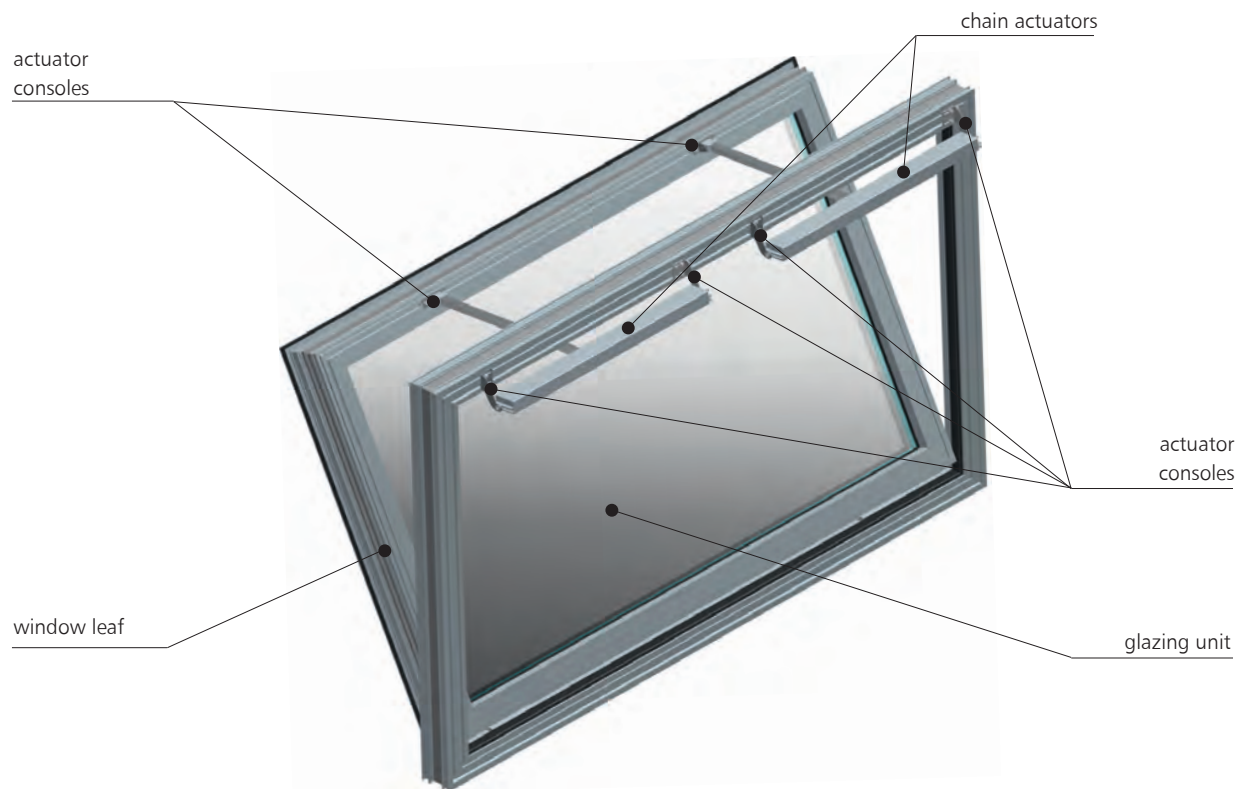


Fig.17 - mcr OSO THERM 75 smoke exhaust window opening outwards by means of two chain actuators

1.1.4. technical drawings of outward-opening smoke exhaust windows

1.1.4.1. technical drawings of the smoke exhaust window with S spindle actuators

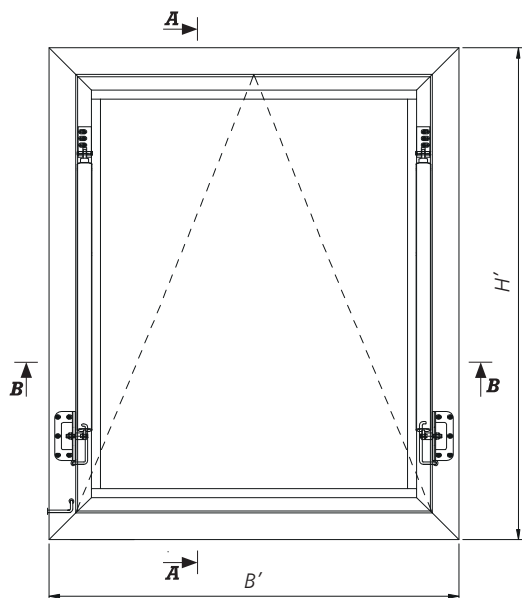


Fig. 18 - view from inside the mcr OSO THERM 75 smoke exhaust window with S spindle actuators in closed position

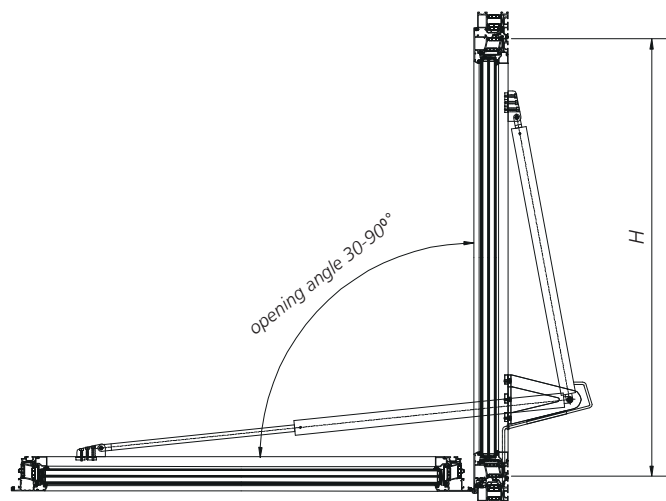


Fig. 19 - A-A vertical cross-section through mcr OSO THERM 75 smoke exhaust window in open position

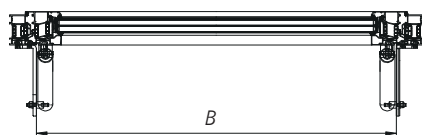


Fig. 20 - B-B horizontal cross-section through mcr OSO THERM 75 smoke exhaust window in closed position

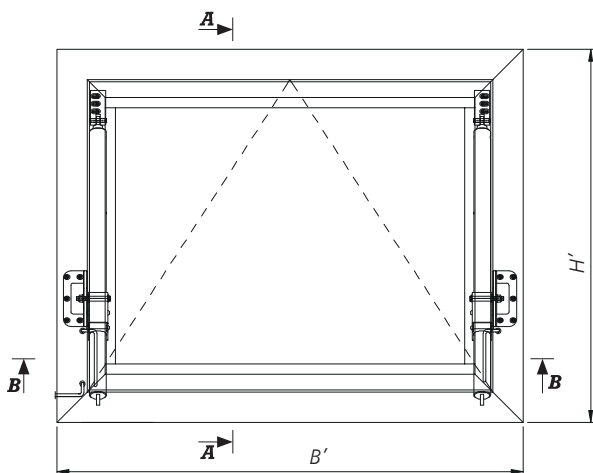


Fig. 21 - view from inside the mcr OSO THERM 75 smoke exhaust window with S spindle actuators with shifted pivot point in closed position

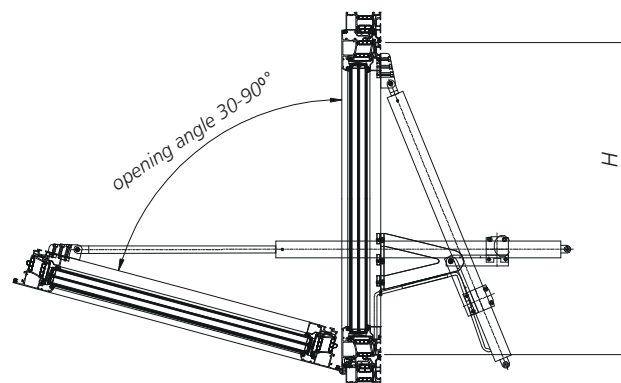


Fig. 22 - A-A vertical cross-section through mcr OSO THERM 75 smoke exhaust window with shifted pivot point in open position

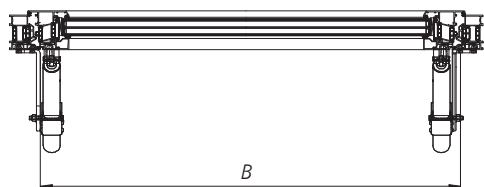


Fig. 23 - B-B horizontal cross-section through mcr OSO THERM 75 smoke exhaust window in closed position

B' - external width of the smoke exhaust window
 H' - external height of the smoke exhaust window
 B - internal width of the smoke exhaust window
 H - internal height of the smoke exhaust window

1.1.4.2. technical drawings of the smoke exhaust window with G spindle actuators

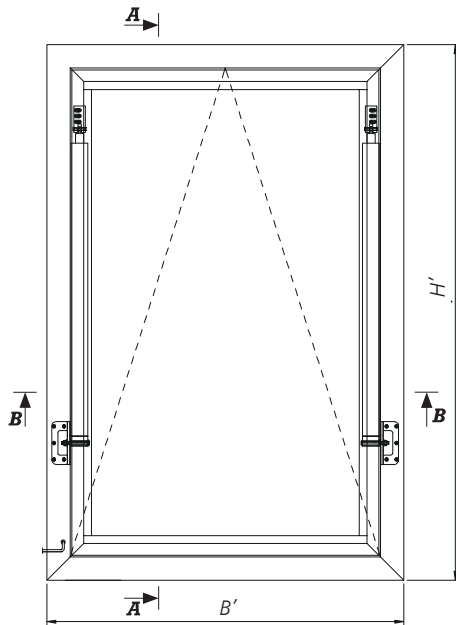


Fig. 24 - view from inside the mcr OSO THERM 75 smoke exhaust window with G spindle actuators in closed position

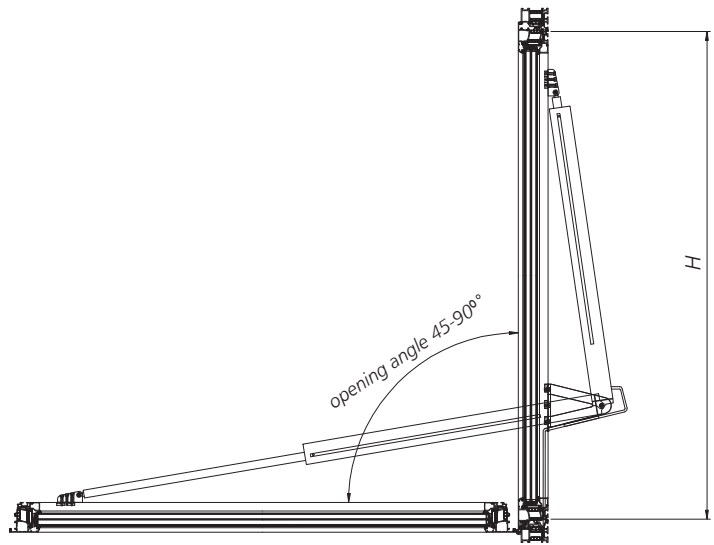


Fig. 25 - A-A vertical cross-section through mcr OSO THERM 75 smoke exhaust window in open position

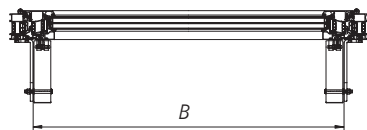


Fig. 26 - B-B horizontal cross-section through smoke exhaust window mcr OSO THERM 75 smoke exhaust window in closed position

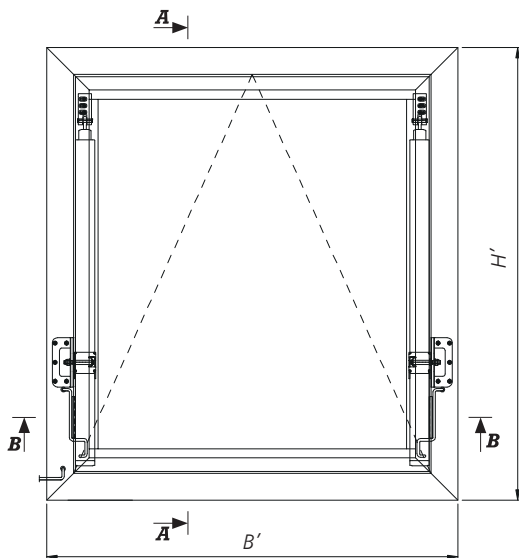


Fig. 27 - view from inside the mcr OSO THERM 75 smoke exhaust window with G spindle actuators with shifted pivot point in closed position

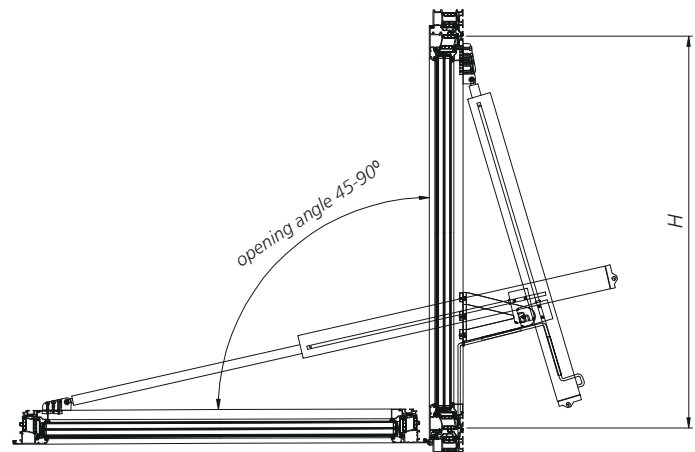


Fig. 28 - A-A vertical cross-section through mcr OSO THERM 75 smoke exhaust window with shifted pivot point in open position

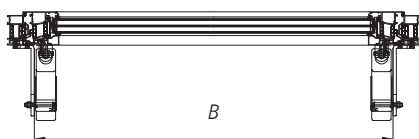


Fig. 29 - B-B horizontal cross-section through mcr OSO THERM 75 smoke exhaust window with shifted pivot point in closed position

B' - external width of the smoke exhaust window
 H' - external height of the smoke exhaust window
 B - internal width of the smoke exhaust window
 H - internal height of the smoke exhaust window

1.1.4.3. technical drawings of the smoke exhaust window with KR10B chain actuator

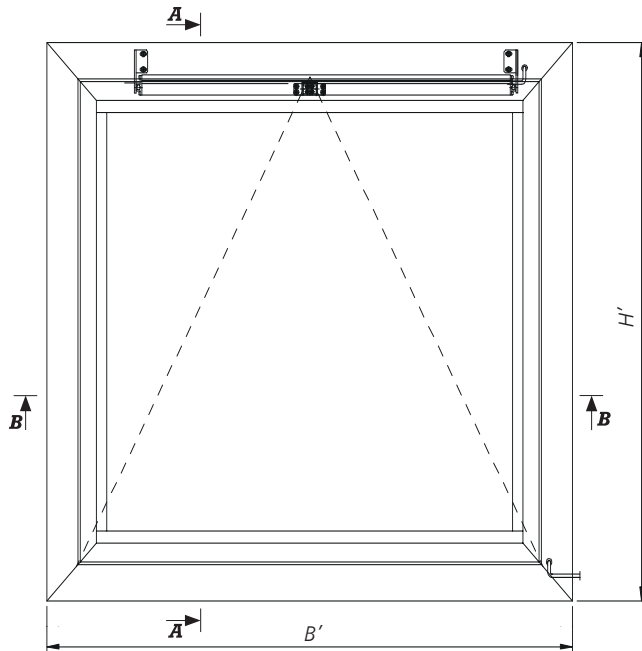


Fig.30 - view from inside the mcr OSO THERM 75 smoke exhaust window with KR10B chain actuator in closed position

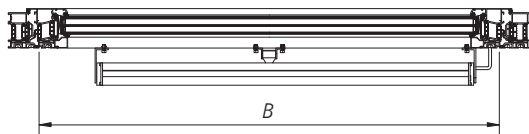


Fig.32 - B-B horizontal cross-section through smoke exhaust window mcr OSO THERM 75 smoke exhaust window in closed position

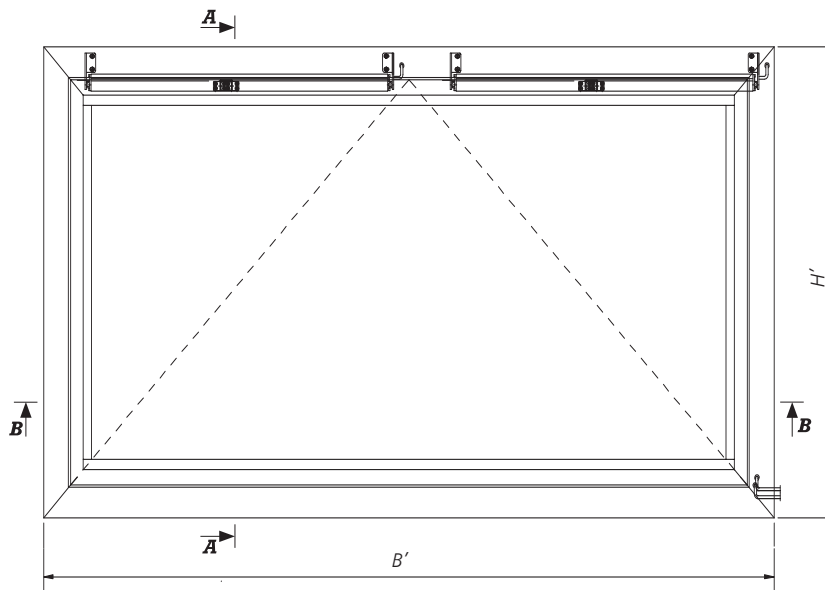


Fig.33 - view from inside the mcr OSO THERM 75 smoke exhaust window with two KR10B chain actuators in closed position

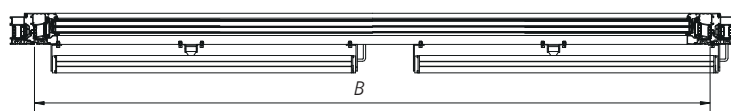


Fig.35 - B-B horizontal cross-section through mcr OSO THERM 75 smoke exhaust window in closed position

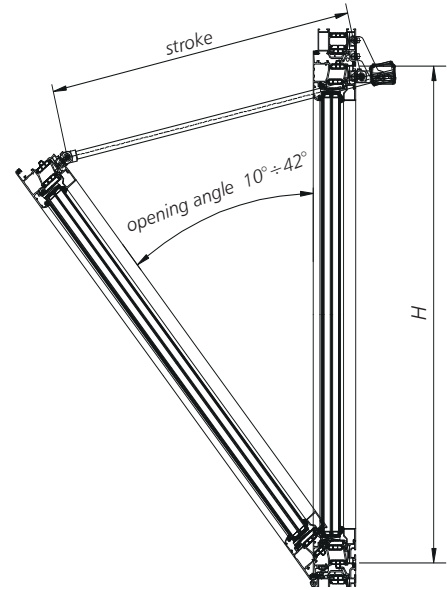


Fig.31 - A-A vertical cross-section through mcr OSO THERM 75 smoke exhaust window in open position

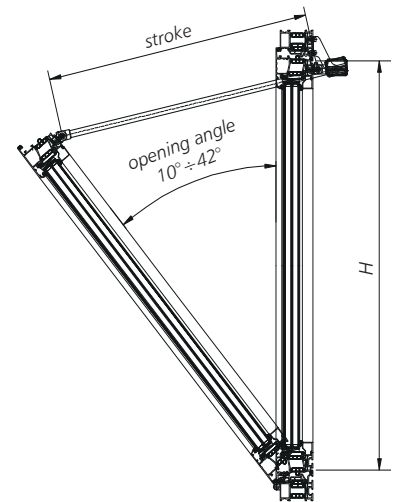


Fig.34 - A-A vertical cross-section through mcr OSO THERM 75 smoke exhaust window in open position

B' - external width of the smoke exhaust window
 H' - external height of the smoke exhaust window
 B - internal width of the smoke exhaust window
 H - internal height of the smoke exhaust window

1.1.4.4. technical drawings of the smoke exhaust window with HCV chain actuator

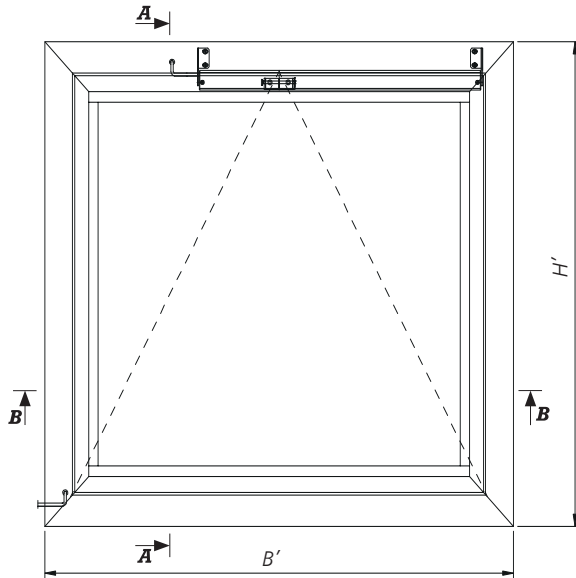


Fig.36 - view from inside the mcr OSO THERM 75 smoke exhaust window with HCV chain actuator in closed position

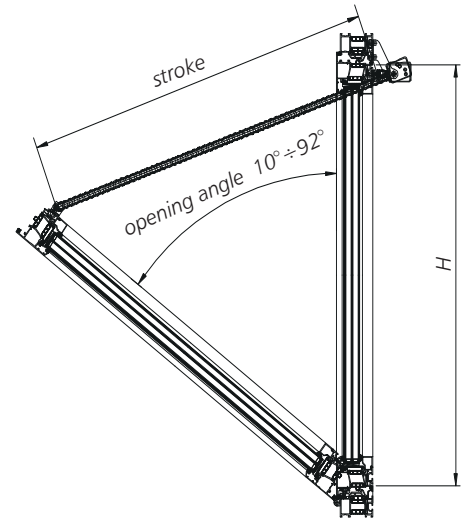
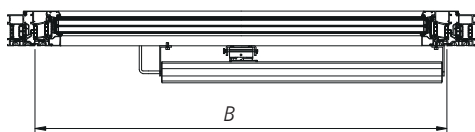
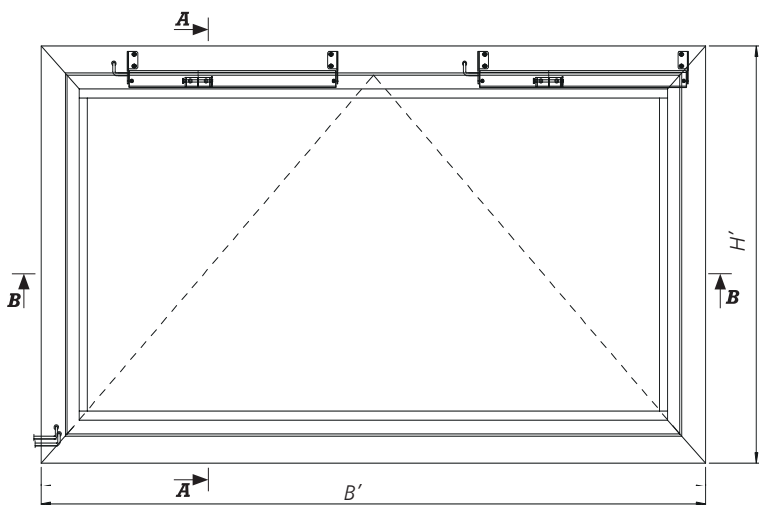


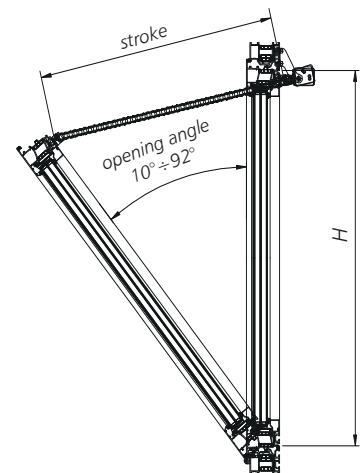
Fig.37 - A-A vertical cross-section through mcr OSO THERM 75 smoke exhaust window in open position



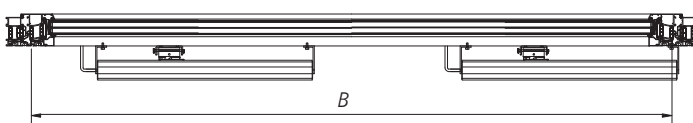
Rys.38 - B-B horizontal cross-section through smoke exhaust window mcr OSO THERM 75 smoke exhaust window in closed position



Rys.39 - view from inside the mcr OSO THERM 75 smoke exhaust window with two HCV chain actuators in closed position



Rys.40 - vertical A-A cross-section through mcr OSO THERM 75 smoke exhaust window in open position



Rys.41 - B-B horizontal cross-section through mcr OSO THERM 75 smoke exhaust window in closed position

B' - external width of the smoke exhaust window
 H' - external height of the smoke exhaust window
 B - internal width of the smoke exhaust window
 H - internal height of the smoke exhaust window

1.1.5. technical specification

1.1.5.1. types of smoke exhaust windows opening outwards by means of spindle actuators

bottom hung outward-opening windows

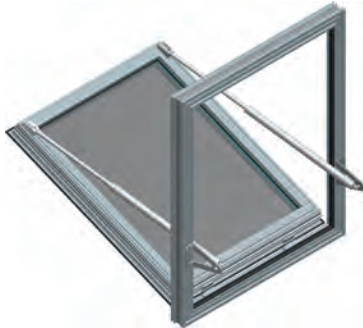


Fig.42 - mcr OSO THERM 75 smoke exhaust window with two S spindle actuators



Fig.43 - mcr OSO THERM 75 smoke exhaust window with two G spindle actuators



Fig.44 - mcr OSO THERM 75 smoke exhaust window with two S spindle actuators with shifted pivot point



Fig.45 - mcr OSO THERM 75 smoke exhaust window with two G spindle actuators with shifted pivot point

top-hung outward-opening windows

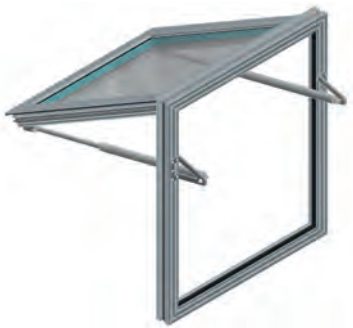


Fig.46 - mcr OSO THERM 75 smoke exhaust window with two S spindle actuators



Fig.47 - mcr OSO THERM 75 smoke exhaust window with two G spindle actuators

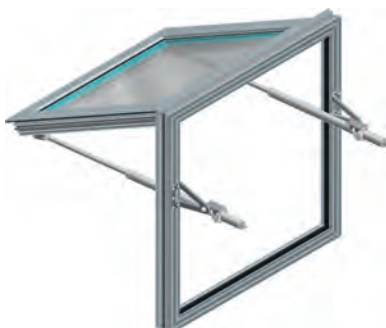


Fig.48 - mcr OSO THERM 75 smoke exhaust window with two S spindle actuators with shifted pivot point



Fig.49 - mcr OSO THERM 75 smoke exhaust window with two G spindle actuators with shifted pivot point

1.1.5.1. technical specification - top- and bottom-opening smoke exhaust windows opening outwards with spindle actuators

| WINDOW SIZE B' x H' [mm] | OPENING ANGLE 30° | | | OPENING ANGLE 45° | | | OPENING ANGLE 60° | | | OPENING ANGLE 75° | | | OPENING ANGLE 90° | | |
|--------------------------------|-------------------|--------------------------|--|-------------------|--------------------------|--|-------------------|--------------------------|--|-------------------|--------------------------|--|-------------------|--------------------------|--|
| | ACTUATOR | POWER CON-SUMPTION** [A] | ACTIVE AERODYNAMIC AREA [Aa] [m ²] | ACTUATOR | POWER CON-SUMPTION** [A] | ACTIVE AERODYNAMIC AREA [Aa] [m ²] | ACTUATOR | POWER CON-SUMPTION** [A] | ACTIVE AERODYNAMIC AREA [Aa] [m ²] | ACTUATOR | POWER CON-SUMPTION** [A] | ACTIVE AERODYNAMIC AREA [Aa] [m ²] | ACTUATOR | POWER CON-SUMPTION** [A] | ACTIVE AERODYNAMIC AREA [Aa] [m ²] |
| 800 x 800 | S08B-200 | 2x0,8 | 0,17 | S08B-300 | 2x0,8 | 0,22 | S08B-300 | 2x0,8 | 0,26 | S10C-400 | 2x1,0 | 0,28 | S10C-400 | 2x1,0 | 0,29 |
| 800 x 900 | S08B-200 | 2x0,8 | 0,21 | S08B-300 | 2x0,8 | 0,26 | S10C-400 | 2x1,0 | 0,30 | S10C-400 | 2x1,0 | 0,32 | S10C-400 | 2x1,0 | 0,34 |
| 800 x 1000 | S08B-200 | 2x0,8 | 0,24 | S10C-350 | 2x1,0 | 0,30 | S10C-400 | 2x1,0 | 0,34 | S10C-450 | 2x1,0 | 0,37 | S10C-400 | 2x1,0 | 0,38 |
| 800 x 1100 | S08B-200 | 2x0,8 | 0,27 | S08B-300 | 2x0,8 | 0,34 | S10C-350 | 2x1,0 | 0,38 | S10C-450 | 2x1,0 | 0,41 | S10C-450 | 2x1,0 | 0,43 |
| 800 x 1200 | S08B-300 | 2x0,8 | 0,31 | S10C-350 | 2x1,0 | 0,38 | S10C-400 | 2x1,0 | 0,43 | S10C-450 | 2x1,0 | 0,45 | S10C-450 | 2x1,0 | 0,47 |
| 800 x 1300 | S10C-350 | 2x1,0 | 0,35 | S10C-450 | 2x1,0 | 0,42 | S10C-450 | 2x1,0 | 0,47 | S10C-450 | 2x1,0 | 0,50 | G26H-600 | 2x2,6 | 0,51 |
| 800 x 1400 | S08B-300 | 2x0,8 | 0,39 | S10C-400 | 2x1,0 | 0,47 | S10C-450 | 2x1,0 | 0,52 | G26H-550 | 2x2,6 | 0,54 | G26H-600 | 2x2,6 | 0,56 |
| 800 x 1500 | S08B-300 | 2x0,8 | 0,44 | S10C-450 | 2x1,0 | 0,51 | S10C-450 | 2x1,0 | 0,56 | G26H-550 | 2x2,6 | 0,59 | G26H-600 | 2x2,6 | 0,60 |
| 800 x 1600 | S10C-350 | 2x1,0 | 0,48 | S10C-450 | 2x1,0 | 0,56 | G26H-550 | 2x2,6 | 0,61 | G26H-600 | 2x2,6 | 0,63 | G26H-600 | 2x2,6 | 0,65 |
| 800 x 1700 | S10C-350 | 2x1,0 | 0,53 | S10C-450 | 2x1,0 | 0,61 | G26H-550 | 2x2,6 | 0,66 | G26H-600 | 2x2,6 | 0,68 | G26H-750 | 2x2,6 | 0,69 |
| 800 x 1800 | S10C-400 | 2x1,0 | 0,58 | G26H-600 | 2x2,6 | 0,66 | G26H-600 | 2x2,6 | 0,70 | G26H-750 | 2x2,6 | 0,72 | G26H-750 | 2x2,6 | 0,73 |
| 800 x 1900 | S10C-400 | 2x1,0 | 0,63 | G26H-550 | 2x2,6 | 0,71 | G26H-750 | 2x2,6 | 0,75 | G26H-750 | 2x2,6 | 0,77 | G26H-750 | 2x2,6 | 0,78 |
| 800 x 2000 | S10C-450 | 2x1,0 | 0,68 | G26H-600 | 2x2,6 | 0,76 | G26H-750 | 2x2,6 | 0,80 | G40H-830 | 2x4,0 | 0,82 | G40H-830 | 2x4,0 | 0,82 |
| 800 x 2100 | S10C-450 | 2x1,0 | 0,74 | G26H-600 | 2x2,6 | 0,81 | G26H-750 | 2x2,6 | 0,85 | G40H-830 | 2x4,0 | 0,86 | G40H-830 | 2x4,0 | 0,87 |
| 800 x 2200 | S10C-450 | 2x1,0 | 0,79 | G26H-600 | 2x2,6 | 0,87 | G26H-750 | 2x2,6 | 0,91 | G40H-830 | 2x4,0 | 0,91 | G40H-830 | 2x4,0 | 0,91 |
| 900 x 800 | S08B-200 | 2x0,8 | 0,20 | S08B-300 | 2x0,8 | 0,26 | S08B-300 | 2x0,8 | 0,29 | S10C-400 | 2x1,0 | 0,32 | S10C-400 | 2x1,0 | 0,34 |
| 900 x 900 | S08B-200 | 2x0,8 | 0,23 | S08B-300 | 2x0,8 | 0,30 | S10C-400 | 2x1,0 | 0,34 | S10C-400 | 2x1,0 | 0,37 | S10C-400 | 2x1,0 | 0,39 |
| 900 x 1000 | S08B-200 | 2x0,8 | 0,27 | S10C-350 | 2x1,0 | 0,34 | S10C-400 | 2x1,0 | 0,39 | S10C-450 | 2x1,0 | 0,42 | S10C-400 | 2x1,0 | 0,44 |
| 900 x 1100 | S08B-200 | 2x0,8 | 0,31 | S08B-300 | 2x0,8 | 0,39 | S10C-350 | 2x1,0 | 0,44 | S10C-450 | 2x1,0 | 0,47 | S10C-450 | 2x1,0 | 0,49 |
| 900 x 1200 | S08B-300 | 2x0,8 | 0,35 | S10C-350 | 2x1,0 | 0,44 | S10C-400 | 2x1,0 | 0,49 | S10C-450 | 2x1,0 | 0,52 | G26H-600 | 2x2,6 | 0,54 |
| 900 x 1300 | S10C-350 | 2x1,0 | 0,40 | S10C-450 | 2x1,0 | 0,48 | S10C-450 | 2x1,0 | 0,54 | S10C-450 | 2x1,0 | 0,57 | G26H-600 | 2x2,6 | 0,59 |
| 900 x 1400 | S08B-300 | 2x0,8 | 0,45 | S10C-400 | 2x1,0 | 0,53 | S10C-450 | 2x1,0 | 0,59 | G26H-550 | 2x2,6 | 0,62 | G26H-600 | 2x2,6 | 0,64 |
| 900 x 1500 | S08B-300 | 2x0,8 | 0,49 | S10C-450 | 2x1,0 | 0,59 | S10C-450 | 2x1,0 | 0,64 | G26H-550 | 2x2,6 | 0,67 | G26H-600 | 2x2,6 | 0,69 |
| 900 x 1600 | S10C-350 | 2x1,0 | 0,55 | S10C-450 | 2x1,0 | 0,64 | G26H-550 | 2x2,6 | 0,70 | G26H-600 | 2x2,6 | 0,73 | G26H-600 | 2x2,6 | 0,74 |
| 900 x 1700 | S10C-350 | 2x1,0 | 0,60 | S10C-450 | 2x1,0 | 0,69 | G26H-550 | 2x2,6 | 0,75 | G26H-600 | 2x2,6 | 0,78 | G26H-750 | 2x2,6 | 0,79 |
| 900 x 1800 | S10C-400 | 2x1,0 | 0,65 | G26H-600 | 2x2,6 | 0,75 | G26H-600 | 2x2,6 | 0,80 | G26H-750 | 2x2,6 | 0,83 | G26H-750 | 2x2,6 | 0,84 |
| 900 x 1900 | S10C-400 | 2x1,0 | 0,71 | G26H-550 | 2x2,6 | 0,81 | G26H-750 | 2x2,6 | 0,86 | G26H-750 | 2x2,6 | 0,88 | G26H-750 | 2x2,6 | 0,89 |
| 900 x 2000 | S10C-450 | 2x1,0 | 0,77 | G26H-600 | 2x2,6 | 0,87 | G26H-750 | 2x2,6 | 0,92 | G40H-830 | 2x4,0 | 0,94 | G40H-830 | 2x4,0 | 0,94 |

(*) It is possible to make intermediate dimensions of the smoke exhaust window between the values given in the table. The size of the active aerodynamic area for these dimensions is determined by linear interpolation.
 (**) Smoke exhaust windows are equipped with a set of two spindle actuators. Power consumption is given for a set of two actuators.

1.1.5.1. technical specification - top- and bottom-opening smoke exhaust windows opening outwards with spindle actuators

| WINDOW SIZE B' x H' [mm] | OPENING ANGLE 30° | | | OPENING ANGLE 45° | | | OPENING ANGLE 60° | | | OPENING ANGLE 75° | | | OPENING ANGLE 90° | | |
|--------------------------------|-------------------|---------------------------|---------------------------------|-------------------|---------------------------|---------------------------------|-------------------|---------------------------|---------------------------------|-------------------|---------------------------|---------------------------------|-------------------|---------------------------|---------------------------------|
| | ACTUATOR | POWER CON-SUMPTION [A] | ACTIVE AERODYNAMIC AREA [Aa] | ACTUATOR | POWER CON-SUMPTION [A] | ACTIVE AERODYNAMIC AREA [Aa] | ACTUATOR | POWER CON-SUMPTION [A] | ACTIVE AERODYNAMIC AREA [Aa] | ACTUATOR | POWER CON-SUMPTION [A] | ACTIVE AERODYNAMIC AREA [Aa] | ACTUATOR | POWER CON-SUMPTION [A] | ACTIVE AERODYNAMIC AREA [Aa] |
| 900 x 2100 | S10C-450 | 2x 1,0 | 0,83 | G26H-600 | 2x 2,6 | 0,93 | G26H-750 | 2x 2,6 | 0,98 | G40H-830 | 2x 4,0 | 0,99 | G40H-830 | 2x 4,0 | 0,99 |
| 900 x 2200 | S10C-450 | 2x 1,0 | 0,90 | G26H-600 | 2x 2,6 | 0,99 | G26H-750 | 2x 2,6 | 1,04 | G40H-830 | 2x 4,0 | 1,04 | G40H-830 | 2x 4,0 | 1,04 |
| 1000 x 800 | S08B-200 | 2x 0,8 | 0,22 | S08B-300 | 2x 0,8 | 0,29 | S08B-300 | 2x 0,8 | 0,33 | S10C-400 | 2x 1,0 | 0,36 | S10C-400 | 2x 1,0 | 0,38 |
| 1000 x 900 | S08B-200 | 2x 0,8 | 0,26 | S08B-300 | 2x 0,8 | 0,34 | S10C-400 | 2x 1,0 | 0,38 | S10C-400 | 2x 1,0 | 0,42 | S10C-400 | 2x 1,0 | 0,44 |
| 1000 x 1000 | S08B-200 | 2x 0,8 | 0,30 | S10C-350 | 2x 1,0 | 0,39 | S10C-400 | 2x 1,0 | 0,44 | S10C-450 | 2x 1,0 | 0,48 | G26G-450 | 2x 2,6 | 0,50 |
| 1000 x 1100 | S08B-200 | 2x 0,8 | 0,35 | S08B-300 | 2x 0,8 | 0,44 | S10C-350 | 2x 1,0 | 0,49 | S10C-450 | 2x 1,0 | 0,53 | G26H-550 | 2x 2,6 | 0,55 |
| 1000 x 1200 | S08B-300 | 2x 0,8 | 0,40 | S10C-350 | 2x 1,0 | 0,49 | S10C-400 | 2x 1,0 | 0,55 | S10C-450 | 2x 1,0 | 0,59 | G26H-600 | 2x 2,6 | 0,61 |
| 1000 x 1300 | S10C-350 | 2x 1,0 | 0,45 | S10C-450 | 2x 1,0 | 0,54 | S10C-450 | 2x 1,0 | 0,61 | S10C-450 | 2x 1,0 | 0,65 | G26H-600 | 2x 2,6 | 0,67 |
| 1000 x 1400 | S08B-300 | 2x 0,8 | 0,50 | S10C-400 | 2x 1,0 | 0,60 | S10C-450 | 2x 1,0 | 0,66 | G26H-550 | 2x 2,6 | 0,70 | G26H-600 | 2x 2,6 | 0,72 |
| 1000 x 1500 | S08B-300 | 2x 0,8 | 0,55 | S10C-450 | 2x 1,0 | 0,66 | S10C-450 | 2x 1,0 | 0,72 | G26H-550 | 2x 2,6 | 0,76 | G26H-600 | 2x 2,6 | 0,78 |
| 1000 x 1600 | S10C-350 | 2x 1,0 | 0,61 | S10C-450 | 2x 1,0 | 0,72 | G26H-550 | 2x 2,6 | 0,78 | G26H-600 | 2x 2,6 | 0,82 | G26H-600 | 2x 2,6 | 0,84 |
| 1000 x 1700 | S10C-350 | 2x 1,0 | 0,67 | S10C-450 | 2x 1,0 | 0,78 | G26H-550 | 2x 2,6 | 0,84 | G26H-600 | 2x 2,6 | 0,88 | G26H-750 | 2x 2,6 | 0,89 |
| 1000 x 1800 | S10C-400 | 2x 1,0 | 0,73 | G26H-600 | 2x 2,6 | 0,84 | G26H-600 | 2x 2,6 | 0,91 | G26H-750 | 2x 2,6 | 0,94 | G26H-750 | 2x 2,6 | 0,95 |
| 1000 x 1900 | S10C-400 | 2x 1,0 | 0,79 | G26H-550 | 2x 2,6 | 0,90 | G26H-750 | 2x 2,6 | 0,97 | G26H-750 | 2x 2,6 | 1,00 | G26H-750 | 2x 2,6 | 1,01 |
| 1000 x 2000 | S10C-450 | 2x 1,0 | 0,86 | G26H-600 | 2x 2,6 | 0,97 | G26H-750 | 2x 2,6 | 1,03 | G40H-830 | 2x 4,0 | 1,06 | G40H-830 | 2x 4,0 | 1,07 |
| 1000 x 2100 | S10C-450 | 2x 1,0 | 0,93 | G26H-600 | 2x 2,6 | 1,04 | G26H-750 | 2x 2,6 | 1,10 | G40H-830 | 2x 4,0 | 1,12 | G40H-830 | 2x 4,0 | 1,12 |
| 1000 x 2200 | S10C-450 | 2x 1,0 | 1,00 | G26H-600 | 2x 2,6 | 1,11 | G26H-750 | 2x 2,6 | 1,16 | G40H-830 | 2x 4,0 | 1,18 | G40H-830 | 2x 4,0 | 1,18 |
| 1100 x 800 | S08B-200 | 2x 0,8 | 0,25 | S08B-300 | 2x 0,8 | 0,32 | S08B-300 | 2x 0,8 | 0,37 | S10C-400 | 2x 1,0 | 0,41 | S10C-400 | 2x 1,0 | 0,43 |
| 1100 x 900 | S08B-200 | 2x 0,8 | 0,29 | S08B-300 | 2x 0,8 | 0,37 | S10C-400 | 2x 1,0 | 0,43 | S10C-400 | 2x 1,0 | 0,47 | S10C-400 | 2x 1,0 | 0,49 |
| 1100 x 1000 | S08B-200 | 2x 0,8 | 0,34 | S10C-350 | 2x 1,0 | 0,43 | S10C-400 | 2x 1,0 | 0,49 | S10C-450 | 2x 1,0 | 0,53 | G26G-450 | 2x 2,6 | 0,55 |
| 1100 x 1100 | S08B-200 | 2x 0,8 | 0,39 | S08B-300 | 2x 0,8 | 0,48 | S10C-350 | 2x 1,0 | 0,55 | S10C-450 | 2x 1,0 | 0,59 | G26H-550 | 2x 2,6 | 0,62 |
| 1100 x 1200 | S08B-300 | 2x 0,8 | 0,44 | S10C-350 | 2x 1,0 | 0,54 | S10C-400 | 2x 1,0 | 0,61 | S10C-450 | 2x 1,0 | 0,66 | G26H-600 | 2x 2,6 | 0,68 |
| 1100 x 1300 | S10C-350 | 2x 1,0 | 0,49 | S10C-450 | 2x 1,0 | 0,60 | S10C-450 | 2x 1,0 | 0,67 | S10C-450 | 2x 1,0 | 0,72 | G26H-600 | 2x 2,6 | 0,74 |
| 1100 x 1400 | S08B-300 | 2x 0,8 | 0,55 | S10C-400 | 2x 1,0 | 0,66 | S10C-450 | 2x 1,0 | 0,74 | G26H-550 | 2x 2,6 | 0,78 | G26H-600 | 2x 2,6 | 0,81 |
| 1100 x 1500 | S08B-300 | 2x 0,8 | 0,61 | S10C-450 | 2x 1,0 | 0,73 | S10C-450 | 2x 1,0 | 0,80 | G26H-550 | 2x 2,6 | 0,85 | G26H-600 | 2x 2,6 | 0,87 |
| 1100 x 1600 | S10C-350 | 2x 1,0 | 0,67 | S10C-450 | 2x 1,0 | 0,79 | G26H-550 | 2x 2,6 | 0,87 | G26H-600 | 2x 2,6 | 0,91 | G26H-600 | 2x 2,6 | 0,93 |
| 1100 x 1700 | S10C-350 | 2x 1,0 | 0,74 | S10C-450 | 2x 1,0 | 0,86 | G26H-550 | 2x 2,6 | 0,94 | G26H-600 | 2x 2,6 | 0,98 | G26H-750 | 2x 2,6 | 1,00 |
| 1100 x 1800 | S10C-400 | 2x 1,0 | 0,80 | G26H-600 | 2x 2,6 | 0,93 | G26H-600 | 2x 2,6 | 1,00 | G26H-750 | 2x 2,6 | 1,04 | G26H-750 | 2x 2,6 | 1,06 |

(*) It is possible to make intermediate dimensions of the smoke exhaust window between the values given in the table. The size of the active aerodynamic area for these dimensions is determined by linear interpolation.
 (***) Smoke exhaust windows are equipped with a set of two spindle actuators. Power consumption is given for a set of two actuators.

1.1.5.1. technical specification - top- and bottom-opening smoke exhaust windows opening outwards with spindle actuators

| WINDOW SIZE* B' x H' [mm] | OPENING ANGLE 30° | | | OPENING ANGLE 45° | | | OPENING ANGLE 60° | | | OPENING ANGLE 75° | | | OPENING ANGLE 90° | | |
|---------------------------------|-------------------|--------------------------|--|-------------------|--------------------------|--|-------------------|--------------------------|--|-------------------|--------------------------|--|-------------------|--------------------------|--|
| | ACTUATOR | POWER CON-SUMPTION** [A] | ACTIVE AERODYNAMIC AREA [Aa] [m ²] | ACTUATOR | POWER CON-SUMPTION** [A] | ACTIVE AERODYNAMIC AREA [Aa] [m ²] | ACTUATOR | POWER CON-SUMPTION** [A] | ACTIVE AERODYNAMIC AREA [Aa] [m ²] | ACTUATOR | POWER CON-SUMPTION** [A] | ACTIVE AERODYNAMIC AREA [Aa] [m ²] | ACTUATOR | POWER CON-SUMPTION** [A] | ACTIVE AERODYNAMIC AREA [Aa] [m ²] |
| 1100 x 1900 | S10C-400 | 2x 1,0 | 0,87 | G26H-550 | 2x 2,6 | 1,00 | G26H-750 | 2x 2,6 | 1,07 | G26H-750 | 2x 2,6 | 1,11 | G26H-750 | 2x 2,6 | 1,12 |
| 1100 x 2000 | S10C-450 | 2x 1,0 | 0,95 | G26H-600 | 2x 2,6 | 1,07 | G26H-750 | 2x 2,6 | 1,15 | G40H-830 | 2x 4,0 | 1,18 | G40H-830 | 2x 4,0 | 1,19 |
| 1100 x 2100 | S10C-450 | 2x 1,0 | 1,02 | G26H-600 | 2x 2,6 | 1,15 | G26H-750 | 2x 2,6 | 1,22 | G40H-830 | 2x 4,0 | 1,24 | G40H-830 | 2x 4,0 | 1,25 |
| 1100 x 2200 | S10C-450 | 2x 1,0 | 1,10 | G26H-600 | 2x 2,6 | 1,23 | G26H-750 | 2x 2,6 | 1,29 | G40H-830 | 2x 4,0 | 1,31 | G40H-830 | 2x 4,0 | 1,32 |
| 1200 x 800 | S08B-200 | 2x 0,8 | 0,27 | S08B-300 | 2x 0,8 | 0,35 | S08B-300 | 2x 0,8 | 0,41 | S10C-400 | 2x 1,0 | 0,45 | S10C-400 | 2x 1,0 | 0,47 |
| 1200 x 900 | S08B-200 | 2x 0,8 | 0,32 | S08B-300 | 2x 0,8 | 0,41 | S10C-400 | 2x 1,0 | 0,47 | S10C-400 | 2x 1,0 | 0,52 | S10C-400 | 2x 1,0 | 0,54 |
| 1200 x 1000 | S08B-200 | 2x 0,8 | 0,37 | S10C-350 | 2x 1,0 | 0,47 | S10C-400 | 2x 1,0 | 0,54 | S10C-450 | 2x 1,0 | 0,58 | G26G-450 | 2x 2,6 | 0,61 |
| 1200 x 1100 | S08B-200 | 2x 0,8 | 0,42 | S08B-300 | 2x 0,8 | 0,53 | S10C-350 | 2x 1,0 | 0,60 | S10C-450 | 2x 1,0 | 0,65 | G26H-550 | 2x 2,6 | 0,68 |
| 1200 x 1200 | S08B-300 | 2x 0,8 | 0,48 | S10C-350 | 2x 1,0 | 0,59 | S10C-400 | 2x 1,0 | 0,67 | S10C-450 | 2x 1,0 | 0,72 | G26H-600 | 2x 2,6 | 0,75 |
| 1200 x 1300 | S10C-350 | 2x 1,0 | 0,54 | S10C-450 | 2x 1,0 | 0,66 | S10C-450 | 2x 1,0 | 0,74 | G26G-450 | 2x 2,6 | 0,79 | G26H-600 | 2x 2,6 | 0,82 |
| 1200 x 1400 | S08B-300 | 2x 0,8 | 0,60 | S10C-400 | 2x 1,0 | 0,73 | S10C-450 | 2x 1,0 | 0,81 | G26H-550 | 2x 2,6 | 0,86 | G26H-600 | 2x 2,6 | 0,89 |
| 1200 x 1500 | S08B-300 | 2x 0,8 | 0,66 | S10C-450 | 2x 1,0 | 0,80 | S10C-450 | 2x 1,0 | 0,88 | G26H-550 | 2x 2,6 | 0,93 | G26H-600 | 2x 2,6 | 0,96 |
| 1200 x 1600 | S10C-350 | 2x 1,0 | 0,73 | S10C-450 | 2x 1,0 | 0,87 | G26H-550 | 2x 2,6 | 0,95 | G26H-600 | 2x 2,6 | 1,00 | G26H-600 | 2x 2,6 | 1,03 |
| 1200 x 1700 | S10C-350 | 2x 1,0 | 0,80 | S10C-450 | 2x 1,0 | 0,94 | G26H-550 | 2x 2,6 | 1,03 | G26H-600 | 2x 2,6 | 1,08 | G26H-750 | 2x 2,6 | 1,10 |
| 1200 x 1800 | S10C-400 | 2x 1,0 | 0,88 | G26H-600 | 2x 2,6 | 1,02 | G26H-600 | 2x 2,6 | 1,10 | G26H-750 | 2x 2,6 | 1,15 | G26H-750 | 2x 2,6 | 1,17 |
| 1200 x 1900 | S10C-400 | 2x 1,0 | 0,95 | G26H-550 | 2x 2,6 | 1,10 | G26H-750 | 2x 2,6 | 1,18 | G26H-750 | 2x 2,6 | 1,22 | G26H-750 | 2x 2,6 | 1,24 |
| 1200 x 2000 | S10C-450 | 2x 1,0 | 1,03 | G26H-600 | 2x 2,6 | 1,18 | G26H-750 | 2x 2,6 | 1,26 | G40H-830 | 2x 4,0 | 1,29 | G40H-830 | 2x 4,0 | 1,31 |
| 1200 x 2100 | S10C-450 | 2x 1,0 | 1,12 | G26H-600 | 2x 2,6 | 1,26 | G26H-750 | 2x 2,6 | 1,34 | G40H-830 | 2x 4,0 | 1,37 | G40H-830 | 2x 4,0 | 1,38 |
| 1200 x 2200 | S10C-450 | 2x 1,0 | 1,20 | G26H-600 | 2x 2,6 | 1,34 | G26H-750 | 2x 2,6 | 1,42 | G40H-830 | 2x 4,0 | 1,44 | G40H-830 | 2x 4,0 | 1,45 |
| 1300 x 800 | S08B-200 | 2x 0,8 | 0,29 | S08B-300 | 2x 0,8 | 0,38 | S08B-300 | 2x 0,8 | 0,44 | S10C-400 | 2x 1,0 | 0,49 | S10C-400 | 2x 1,0 | 0,51 |
| 1300 x 900 | S08B-200 | 2x 0,8 | 0,34 | S08B-300 | 2x 0,8 | 0,45 | S10C-400 | 2x 1,0 | 0,51 | S10C-400 | 2x 1,0 | 0,56 | G26G-450 | 2x 2,6 | 0,59 |
| 1300 x 1000 | S08B-200 | 2x 0,8 | 0,40 | S10C-350 | 2x 1,0 | 0,51 | S10C-400 | 2x 1,0 | 0,59 | S10C-450 | 2x 1,0 | 0,64 | G26G-450 | 2x 2,6 | 0,67 |
| 1300 x 1100 | S08B-200 | 2x 0,8 | 0,46 | S08B-300 | 2x 0,8 | 0,58 | S10C-350 | 2x 1,0 | 0,66 | S10C-450 | 2x 1,0 | 0,71 | G26H-550 | 2x 2,6 | 0,74 |
| 1300 x 1200 | S08B-300 | 2x 0,8 | 0,52 | S10C-350 | 2x 1,0 | 0,65 | S10C-400 | 2x 1,0 | 0,73 | S10C-450 | 2x 1,0 | 0,79 | G26H-600 | 2x 2,6 | 0,82 |
| 1300 x 1300 | S10C-350 | 2x 1,0 | 0,58 | S10C-450 | 2x 1,0 | 0,72 | S10C-450 | 2x 1,0 | 0,81 | G26G-450 | 2x 2,6 | 0,87 | G26H-600 | 2x 2,6 | 0,90 |
| 1300 x 1400 | S08B-300 | 2x 0,8 | 0,65 | S10C-400 | 2x 1,0 | 0,79 | S10C-450 | 2x 1,0 | 0,88 | G26H-550 | 2x 2,6 | 0,94 | G26H-600 | 2x 2,6 | 0,97 |
| 1300 x 1500 | S08B-300 | 2x 0,8 | 0,72 | S10C-450 | 2x 1,0 | 0,87 | S10C-450 | 2x 1,0 | 0,96 | G26H-550 | 2x 2,6 | 1,02 | G26H-600 | 2x 2,6 | 1,05 |
| 1300 x 1600 | S10C-350 | 2x 1,0 | 0,79 | S10C-450 | 2x 1,0 | 0,94 | G26H-550 | 2x 2,6 | 1,04 | G26H-600 | 2x 2,6 | 1,10 | G26H-600 | 2x 2,6 | 1,13 |

(*) It is possible to make intermediate dimensions of the smoke exhaust window between the values given in the table. The size of the active aerodynamic area for these dimensions is determined by linear interpolation.

(**) Smoke exhaust windows are equipped with a set of two spindle actuators. Power consumption is given for a set of two actuators.

1.1.5.1. technical specification - top- and bottom-opening smoke exhaust windows opening outwards with spindle actuators

| WINDOW SIZE* B' x H' [mm] | OPENING ANGLE 30° | | | OPENING ANGLE 45° | | | OPENING ANGLE 60° | | | OPENING ANGLE 75° | | | OPENING ANGLE 90° | | |
|---------------------------------|-------------------|--------------------------|--|-------------------|--------------------------|--|-------------------|--------------------------|--|-------------------|--------------------------|--|-------------------|--------------------------|--|
| | ACTUATOR | POWER CON-SUMPTION** [A] | ACTIVE AERODYNAMIC AREA [Aa] [m ²] | ACTUATOR | POWER CON-SUMPTION** [A] | ACTIVE AERODYNAMIC AREA [Aa] [m ²] | ACTUATOR | POWER CON-SUMPTION** [A] | ACTIVE AERODYNAMIC AREA [Aa] [m ²] | ACTUATOR | POWER CON-SUMPTION** [A] | ACTIVE AERODYNAMIC AREA [Aa] [m ²] | ACTUATOR | POWER CON-SUMPTION** [A] | ACTIVE AERODYNAMIC AREA [Aa] [m ²] |
| 1300 x 1700 | S10C-350 | 2x 1,0 | 0,87 | S10C-450 | 2x 1,0 | 1,02 | G26H-550 | 2x 2,6 | 1,12 | G26H-600 | 2x 2,6 | 1,18 | G26H-750 | 2x 2,6 | 1,20 |
| 1300 x 1800 | S10C-400 | 2x 1,0 | 0,95 | G26H-600 | 2x 2,6 | 1,11 | G26H-600 | 2x 2,6 | 1,20 | G26H-750 | 2x 2,6 | 1,25 | G26H-750 | 2x 2,6 | 1,28 |
| 1300 x 1900 | S10C-400 | 2x 1,0 | 1,03 | G26H-550 | 2x 2,6 | 1,19 | G26H-750 | 2x 2,6 | 1,29 | G26H-750 | 2x 2,6 | 1,33 | G26H-750 | 2x 2,6 | 1,36 |
| 1300 x 2000 | S10C-450 | 2x 1,0 | 1,12 | G26H-600 | 2x 2,6 | 1,28 | G26H-750 | 2x 2,6 | 1,37 | G40H-830 | 2x 4,0 | 1,41 | G40H-830 | 2x 4,0 | 1,43 |
| 1300 x 2100 | S10C-450 | 2x 1,0 | 1,21 | G26H-600 | 2x 2,6 | 1,37 | G26H-750 | 2x 2,6 | 1,46 | G40H-830 | 2x 4,0 | 1,49 | G40H-830 | 2x 4,0 | 1,51 |
| 1300 x 2200 | S10C-450 | 2x 1,0 | 1,30 | G26H-600 | 2x 2,6 | 1,46 | G26H-750 | 2x 2,6 | 1,54 | G40H-830 | 2x 4,0 | 1,58 | G40H-830 | 2x 4,0 | 1,59 |
| 1400 x 800 | S08B-200 | 2x 0,8 | 0,32 | S08B-300 | 2x 0,8 | 0,41 | S08B-300 | 2x 0,8 | 0,48 | S10C-400 | 2x 1,0 | 0,53 | S10C-400 | 2x 1,0 | 0,56 |
| 1400 x 900 | S08B-200 | 2x 0,8 | 0,37 | S08B-300 | 2x 0,8 | 0,48 | S10C-400 | 2x 1,0 | 0,56 | S10C-400 | 2x 1,0 | 0,61 | G26G-450 | 2x 2,6 | 0,64 |
| 1400 x 1000 | S08B-200 | 2x 0,8 | 0,43 | S10C-350 | 2x 1,0 | 0,55 | S10C-400 | 2x 1,0 | 0,63 | S10C-450 | 2x 1,0 | 0,69 | G26G-450 | 2x 2,6 | 0,72 |
| 1400 x 1100 | S08B-200 | 2x 0,8 | 0,49 | S08B-300 | 2x 0,8 | 0,62 | S10C-350 | 2x 1,0 | 0,71 | S10C-450 | 2x 1,0 | 0,77 | G26H-550 | 2x 2,6 | 0,81 |
| 1400 x 1200 | S08B-300 | 2x 0,8 | 0,56 | S10C-350 | 2x 1,0 | 0,70 | S10C-400 | 2x 1,0 | 0,79 | S10C-450 | 2x 1,0 | 0,86 | G26H-600 | 2x 2,6 | 0,89 |
| 1400 x 1300 | S10C-350 | 2x 1,0 | 0,63 | S10C-450 | 2x 1,0 | 0,78 | S10C-450 | 2x 1,0 | 0,87 | G26G-450 | 2x 2,6 | 0,94 | G26H-600 | 2x 2,6 | 0,97 |
| 1400 x 1400 | S08B-300 | 2x 0,8 | 0,70 | S10C-400 | 2x 1,0 | 0,85 | S10C-450 | 2x 1,0 | 0,96 | G26H-550 | 2x 2,6 | 1,02 | G26H-600 | 2x 2,6 | 1,06 |
| 1400 x 1500 | S08B-300 | 2x 0,8 | 0,77 | S10C-450 | 2x 1,0 | 0,94 | S10C-450 | 2x 1,0 | 1,04 | G26H-550 | 2x 2,6 | 1,11 | G26H-600 | 2x 2,6 | 1,14 |
| 1400 x 1600 | S10C-350 | 2x 1,0 | 0,85 | S10C-450 | 2x 1,0 | 1,02 | G26H-550 | 2x 2,6 | 1,12 | G26H-600 | 2x 2,6 | 1,19 | G26H-600 | 2x 2,6 | 1,22 |
| 1400 x 1700 | S10C-350 | 2x 1,0 | 0,93 | S10C-450 | 2x 1,0 | 1,10 | G26H-550 | 2x 2,6 | 1,21 | G26H-600 | 2x 2,6 | 1,27 | G26H-750 | 2x 2,6 | 1,31 |
| 1400 x 1800 | S10C-400 | 2x 1,0 | 1,02 | G26H-600 | 2x 2,6 | 1,19 | G26H-600 | 2x 2,6 | 1,30 | G26H-750 | 2x 2,6 | 1,36 | G26H-750 | 2x 2,6 | 1,39 |
| 1400 x 1900 | S10C-400 | 2x 1,0 | 1,11 | G26H-550 | 2x 2,6 | 1,28 | G26H-750 | 2x 2,6 | 1,39 | G26H-750 | 2x 2,6 | 1,45 | G26H-750 | 2x 2,6 | 1,47 |
| 1400 x 2000 | S10C-450 | 2x 1,0 | 1,20 | G26H-600 | 2x 2,6 | 1,38 | G26H-750 | 2x 2,6 | 1,48 | G40H-830 | 2x 4,0 | 1,53 | G40H-830 | 2x 4,0 | 1,56 |
| 1400 x 2100 | S10C-450 | 2x 1,0 | 1,29 | G26H-600 | 2x 2,6 | 1,47 | G26H-750 | 2x 2,6 | 1,58 | G40H-830 | 2x 4,0 | 1,62 | G40H-830 | 2x 4,0 | 1,64 |
| 1400 x 2200 | S10C-450 | 2x 1,0 | 1,39 | G26H-600 | 2x 2,6 | 1,57 | G26H-750 | 2x 2,6 | 1,67 | G40H-830 | 2x 4,0 | 1,71 | G40H-830 | 2x 4,0 | 1,72 |
| 1500 x 800 | S08B-200 | 2x 0,8 | 0,34 | S08B-300 | 2x 0,8 | 0,45 | S08B-300 | 2x 0,8 | 0,52 | S10C-400 | 2x 1,0 | 0,57 | S10C-400 | 2x 1,0 | 0,60 |
| 1500 x 900 | S08B-200 | 2x 0,8 | 0,40 | S08B-300 | 2x 0,8 | 0,52 | S10C-400 | 2x 1,0 | 0,60 | S10C-400 | 2x 1,0 | 0,66 | G26G-450 | 2x 2,6 | 0,69 |
| 1500 x 1000 | S08B-200 | 2x 0,8 | 0,46 | S10C-350 | 2x 1,0 | 0,59 | S10C-400 | 2x 1,0 | 0,68 | S10C-450 | 2x 1,0 | 0,75 | G26G-450 | 2x 2,6 | 0,78 |
| 1500 x 1100 | S08B-200 | 2x 0,8 | 0,53 | S08B-300 | 2x 0,8 | 0,67 | S10C-350 | 2x 1,0 | 0,77 | S10C-450 | 2x 1,0 | 0,83 | G26H-550 | 2x 2,6 | 0,87 |
| 1500 x 1200 | S08B-300 | 2x 0,8 | 0,60 | S10C-350 | 2x 1,0 | 0,75 | S10C-400 | 2x 1,0 | 0,85 | G26G-450 | 2x 2,6 | 0,92 | G26H-600 | 2x 2,6 | 0,96 |
| 1500 x 1300 | S10C-350 | 2x 1,0 | 0,67 | S10C-450 | 2x 1,0 | 0,83 | S10C-450 | 2x 1,0 | 0,94 | G26G-450 | 2x 2,6 | 1,01 | G26H-600 | 2x 2,6 | 1,05 |
| 1500 x 1400 | S08B-300 | 2x 0,8 | 0,75 | S10C-400 | 2x 1,0 | 0,92 | S10C-450 | 2x 1,0 | 1,03 | G26H-550 | 2x 2,6 | 1,10 | G26H-600 | 2x 2,6 | 1,14 |

(*) It is possible to make intermediate dimensions of the smoke exhaust window between the values given in the table. The size of the active aerodynamic area for these dimensions is determined by linear interpolation.
 (***) Smoke exhaust windows are equipped with a set of two spindle actuators. Power consumption is given for a set of two actuators.

1.1.5.1. technical specification - top- and bottom-opening smoke exhaust windows opening outwards with spindle actuators

| WINDOW SIZE* B' x H' | OPENING ANGLE 30° | | | OPENING ANGLE 45° | | | OPENING ANGLE 60° | | | OPENING ANGLE 75° | | | OPENING ANGLE 90° | | |
|-------------------------|-------------------|--------------------------|--|-------------------|--------------------------|--|-------------------|--------------------------|--|-------------------|--------------------------|--|-------------------|--------------------------|--|
| | ACTUATOR | POWER CON-SUMPTION** [A] | ACTIVE AERODYNAMIC AREA [Aa] [m ²] | ACTUATOR | POWER CON-SUMPTION** [A] | ACTIVE AERODYNAMIC AREA [Aa] [m ²] | ACTUATOR | POWER CON-SUMPTION** [A] | ACTIVE AERODYNAMIC AREA [Aa] [m ²] | ACTUATOR | POWER CON-SUMPTION** [A] | ACTIVE AERODYNAMIC AREA [Aa] [m ²] | ACTUATOR | POWER CON-SUMPTION** [A] | ACTIVE AERODYNAMIC AREA [Aa] [m ²] |
| 1500 x 1500 | S088-300 | 2x 0,8 | 0,83 | S10C-450 | 2x 1,0 | 1,00 | S10C-450 | 2x 1,0 | 1,12 | G26H-550 | 2x 2,6 | 1,19 | G26H-600 | 2x 2,6 | 1,23 |
| 1500 x 1600 | S10C-350 | 2x 1,0 | 0,91 | S10C-450 | 2x 1,0 | 1,09 | G26H-550 | 2x 2,6 | 1,21 | G26H-600 | 2x 2,6 | 1,28 | G26H-600 | 2x 2,6 | 1,32 |
| 1500 x 1700 | S10C-350 | 2x 1,0 | 1,00 | S10C-450 | 2x 1,0 | 1,18 | G26H-550 | 2x 2,6 | 1,30 | G26H-600 | 2x 2,6 | 1,37 | G26H-750 | 2x 2,6 | 1,41 |
| 1500 x 1800 | S10C-400 | 2x 1,0 | 1,09 | G26H-600 | 2x 2,6 | 1,28 | G26H-600 | 2x 2,6 | 1,40 | G26H-750 | 2x 2,6 | 1,46 | G26H-750 | 2x 2,6 | 1,50 |
| 1500 x 1900 | S10C-400 | 2x 1,0 | 1,18 | G26H-550 | 2x 2,6 | 1,38 | G26H-750 | 2x 2,6 | 1,49 | G26H-750 | 2x 2,6 | 1,56 | G26H-750 | 2x 2,6 | 1,59 |
| 1500 x 2000 | S10C-450 | 2x 1,0 | 1,28 | G26H-600 | 2x 2,6 | 1,48 | G26H-750 | 2x 2,6 | 1,59 | G40H-830 | 2x 4,0 | 1,65 | G40H-830 | 2x 4,0 | 1,68 |
| 1500 x 2100 | S10C-450 | 2x 1,0 | 1,38 | G26H-600 | 2x 2,6 | 1,58 | G26H-750 | 2x 2,6 | 1,69 | G40H-830 | 2x 4,0 | 1,74 | G40H-830 | 2x 4,0 | 1,77 |
| 1500 x 2200 | S10C-450 | 2x 1,0 | 1,49 | G26H-600 | 2x 2,6 | 1,68 | G26H-750 | 2x 2,6 | 1,79 | G40H-830 | 2x 4,0 | 1,84 | G40H-830 | 2x 4,0 | 1,86 |
| 1600 x 800 | S088-200 | 2x 0,8 | 0,36 | S088-300 | 2x 0,8 | 0,48 | S088-300 | 2x 0,8 | 0,56 | S10C-400 | 2x 1,0 | 0,61 | S10C-400 | 2x 1,0 | 0,64 |
| 1600 x 900 | S088-200 | 2x 0,8 | 0,43 | S088-300 | 2x 0,8 | 0,56 | S10C-400 | 2x 1,0 | 0,64 | S10C-400 | 2x 1,0 | 0,71 | G26G-450 | 2x 2,6 | 0,74 |
| 1600 x 1000 | S088-200 | 2x 0,8 | 0,49 | S10C-350 | 2x 1,0 | 0,64 | S10C-400 | 2x 1,0 | 0,73 | S10C-450 | 2x 1,0 | 0,80 | G26G-450 | 2x 2,6 | 0,84 |
| 1600 x 1100 | S088-200 | 2x 0,8 | 0,56 | S088-300 | 2x 0,8 | 0,72 | S10C-350 | 2x 1,0 | 0,82 | S10C-450 | 2x 1,0 | 0,89 | G26H-550 | 2x 2,6 | 0,93 |
| 1600 x 1200 | S088-300 | 2x 0,8 | 0,64 | S10C-350 | 2x 1,0 | 0,80 | S10C-400 | 2x 1,0 | 0,91 | G26G-450 | 2x 2,6 | 0,99 | G26H-600 | 2x 2,6 | 1,03 |
| 1600 x 1300 | S10C-350 | 2x 1,0 | 0,71 | S10C-450 | 2x 1,0 | 0,89 | S10C-450 | 2x 1,0 | 1,01 | G26G-450 | 2x 2,6 | 1,08 | G26H-600 | 2x 2,6 | 1,13 |
| 1600 x 1400 | S088-300 | 2x 0,8 | 0,79 | S10C-400 | 2x 1,0 | 0,98 | S10C-450 | 2x 1,0 | 1,10 | G26H-550 | 2x 2,6 | 1,18 | G26H-600 | 2x 2,6 | 1,22 |
| 1600 x 1500 | S088-300 | 2x 0,8 | 0,88 | S10C-450 | 2x 1,0 | 1,07 | G26G-450 | 2x 2,6 | 1,20 | G26H-550 | 2x 2,6 | 1,28 | G26H-600 | 2x 2,6 | 1,32 |
| 1600 x 1600 | S10C-350 | 2x 1,0 | 0,97 | S10C-450 | 2x 1,0 | 1,17 | G26H-550 | 2x 2,6 | 1,29 | G26H-600 | 2x 2,6 | 1,37 | G26H-600 | 2x 2,6 | 1,42 |
| 1600 x 1700 | S10C-350 | 2x 1,0 | 1,06 | S10C-450 | 2x 1,0 | 1,26 | G26H-550 | 2x 2,6 | 1,39 | G26H-600 | 2x 2,6 | 1,47 | G26H-750 | 2x 2,6 | 1,51 |
| 1600 x 1800 | S10C-400 | 2x 1,0 | 1,15 | G26H-600 | 2x 2,6 | 1,36 | G26H-600 | 2x 2,6 | 1,50 | G26H-750 | 2x 2,6 | 1,57 | G26H-750 | 2x 2,6 | 1,61 |
| 1600 x 1900 | S10C-400 | 2x 1,0 | 1,25 | G26H-550 | 2x 2,6 | 1,47 | G26H-750 | 2x 2,6 | 1,60 | G26H-750 | 2x 2,6 | 1,67 | G40H-830 | 2x 4,0 | 1,70 |
| 1600 x 2000 | S10C-450 | 2x 1,0 | 1,36 | G26H-600 | 2x 2,6 | 1,57 | G26H-750 | 2x 2,6 | 1,70 | G40H-830 | 2x 4,0 | 1,77 | G40H-830 | 2x 4,0 | 1,80 |
| 1600 x 2100 | S10C-450 | 2x 1,0 | 1,47 | G26H-600 | 2x 2,6 | 1,68 | G26H-750 | 2x 2,6 | 1,81 | G40H-830 | 2x 4,0 | 1,87 | G40H-830 | 2x 4,0 | 1,90 |
| 1600 x 2200 | S10C-450 | 2x 1,0 | 1,58 | G26H-600 | 2x 2,6 | 1,79 | G26H-750 | 2x 2,6 | 1,92 | G40H-830 | 2x 4,0 | 1,97 | G40H-830 | 2x 4,0 | 1,99 |
| 1700 x 800 | S088-200 | 2x 0,8 | 0,39 | S088-300 | 2x 0,8 | 0,51 | S088-300 | 2x 0,8 | 0,59 | S10C-400 | 2x 1,0 | 0,65 | G26G-450 | 2x 2,6 | 0,69 |
| 1700 x 900 | S088-200 | 2x 0,8 | 0,45 | S088-300 | 2x 0,8 | 0,59 | S10C-400 | 2x 1,0 | 0,69 | S10C-400 | 2x 1,0 | 0,75 | G26G-450 | 2x 2,6 | 0,79 |
| 1700 x 1000 | S088-200 | 2x 0,8 | 0,52 | S10C-350 | 2x 1,0 | 0,68 | S10C-400 | 2x 1,0 | 0,78 | S10C-450 | 2x 1,0 | 0,85 | G26G-450 | 2x 2,6 | 0,89 |
| 1700 x 1100 | S088-200 | 2x 0,8 | 0,60 | S088-300 | 2x 0,8 | 0,76 | S10C-350 | 2x 1,0 | 0,88 | G26G-450 | 2x 2,6 | 0,95 | G26H-550 | 2x 2,6 | 1,00 |
| 1700 x 1200 | S088-300 | 2x 0,8 | 0,67 | S10C-350 | 2x 1,0 | 0,85 | S10C-400 | 2x 1,0 | 0,97 | G26G-450 | 2x 2,6 | 1,06 | G26H-600 | 2x 2,6 | 1,10 |

(*) It is possible to make intermediate dimensions of the smoke exhaust window between the values given in the table. The size of the active aerodynamic area for these dimensions is determined by linear interpolation.
 (***) Smoke exhaust windows are equipped with a set of two spindle actuators. Power consumption is given for a set of two actuators.

1.1.5.1. technical specification - top- and bottom-opening smoke exhaust windows opening outwards with spindle actuators

| WINDOW SIZE* B' x H' [mm] | OPENING ANGLE 30° | | | OPENING ANGLE 45° | | | OPENING ANGLE 60° | | | OPENING ANGLE 75° | | | OPENING ANGLE 90° | | |
|---------------------------------|-------------------|--------------------------|-----------------------------------|-------------------|--------------------------|-----------------------------------|-------------------|--------------------------|-----------------------------------|-------------------|--------------------------|-----------------------------------|-------------------|--------------------------|-----------------------------------|
| | ACTUATOR | POWER CON-SUMPTION** [A] | ACTIVE AERODYNAMIC AREA [Aa] [m²] | ACTUATOR | POWER CON-SUMPTION** [A] | ACTIVE AERODYNAMIC AREA [Aa] [m²] | ACTUATOR | POWER CON-SUMPTION** [A] | ACTIVE AERODYNAMIC AREA [Aa] [m²] | ACTUATOR | POWER CON-SUMPTION** [A] | ACTIVE AERODYNAMIC AREA [Aa] [m²] | ACTUATOR | POWER CON-SUMPTION** [A] | ACTIVE AERODYNAMIC AREA [Aa] [m²] |
| 1700 x 1300 | S10C-350 | 2x 1,0 | 0,76 | S10C-450 | 2x 1,0 | 0,95 | S10C-450 | 2x 1,0 | 1,07 | G26G-450 | 2x 2,6 | 1,16 | G26H-600 | 2x 2,6 | 1,20 |
| 1700 x 1400 | S08B-300 | 2x 0,8 | 0,84 | S10C-400 | 2x 1,0 | 1,04 | S10C-450 | 2x 1,0 | 1,17 | G26H-550 | 2x 2,6 | 1,26 | G26H-600 | 2x 2,6 | 1,31 |
| 1700 x 1500 | S08B-300 | 2x 0,8 | 0,93 | S10C-450 | 2x 1,0 | 1,14 | G26G-450 | 2x 2,6 | 1,27 | G26H-550 | 2x 2,6 | 1,36 | G26H-600 | 2x 2,6 | 1,41 |
| 1700 x 1600 | S10C-350 | 2x 1,0 | 1,02 | S10C-450 | 2x 1,0 | 1,24 | G26H-550 | 2x 2,6 | 1,38 | G26H-600 | 2x 2,6 | 1,47 | G26H-750 | 2x 2,6 | 1,51 |
| 1700 x 1700 | S10C-350 | 2x 1,0 | 1,12 | S10C-450 | 2x 1,0 | 1,34 | G26H-550 | 2x 2,6 | 1,48 | G26H-600 | 2x 2,6 | 1,57 | G26H-750 | 2x 2,6 | 1,61 |
| 1700 x 1800 | S10C-400 | 2x 1,0 | 1,22 | G26H-600 | 2x 2,6 | 1,45 | G26H-600 | 2x 2,6 | 1,59 | G26H-750 | 2x 2,6 | 1,68 | G26H-750 | 2x 2,6 | 1,72 |
| 1700 x 1900 | S10C-400 | 2x 1,0 | 1,33 | G26H-550 | 2x 2,6 | 1,56 | G26H-750 | 2x 2,6 | 1,70 | G26H-750 | 2x 2,6 | 1,78 | G40H-830 | 2x 4,0 | 1,82 |
| 1700 x 2000 | S10C-450 | 2x 1,0 | 1,44 | G26H-600 | 2x 2,6 | 1,67 | G26H-750 | 2x 2,6 | 1,81 | G40H-830 | 2x 4,0 | 1,89 | G40H-830 | 2x 4,0 | 1,92 |
| 1800 x 800 | S08B-200 | 2x 0,8 | 0,41 | S08B-300 | 2x 0,8 | 0,54 | S08B-300 | 2x 0,8 | 0,63 | S10C-400 | 2x 1,0 | 0,70 | G26G-450 | 2x 2,6 | 0,73 |
| 1800 x 900 | S08B-200 | 2x 0,8 | 0,48 | S08B-300 | 2x 0,8 | 0,63 | S10C-400 | 2x 1,0 | 0,73 | S10C-400 | 2x 1,0 | 0,80 | G26G-450 | 2x 2,6 | 0,84 |
| 1800 x 1000 | S08B-200 | 2x 0,8 | 0,55 | S10C-350 | 2x 1,0 | 0,72 | S10C-400 | 2x 1,0 | 0,83 | S10C-450 | 2x 1,0 | 0,91 | G26G-450 | 2x 2,6 | 0,95 |
| 1800 x 1100 | S08B-200 | 2x 0,8 | 0,63 | S08B-300 | 2x 0,8 | 0,81 | S10C-350 | 2x 1,0 | 0,93 | G26G-450 | 2x 2,6 | 1,01 | G26H-550 | 2x 2,6 | 1,06 |
| 1800 x 1200 | S08B-300 | 2x 0,8 | 0,71 | S10C-350 | 2x 1,0 | 0,91 | S10C-400 | 2x 1,0 | 1,03 | G26G-450 | 2x 2,6 | 1,12 | G26H-600 | 2x 2,6 | 1,17 |
| 1800 x 1300 | S10C-350 | 2x 1,0 | 0,80 | S10C-450 | 2x 1,0 | 1,00 | S10C-450 | 2x 1,0 | 1,14 | G26G-450 | 2x 2,6 | 1,23 | G26H-600 | 2x 2,6 | 1,28 |
| 1800 x 1400 | S08B-300 | 2x 0,8 | 0,89 | S10C-400 | 2x 1,0 | 1,10 | G26G-450 | 2x 2,6 | 1,24 | G26H-550 | 2x 2,6 | 1,34 | G26H-600 | 2x 2,6 | 1,39 |
| 1800 x 1500 | S08B-300 | 2x 0,8 | 0,98 | S10C-450 | 2x 1,0 | 1,21 | G26G-450 | 2x 2,6 | 1,35 | G26H-550 | 2x 2,6 | 1,45 | G26H-601 | 2x 2,6 | 1,50 |
| 1800 x 1600 | S10C-350 | 2x 1,0 | 1,08 | S10C-450 | 2x 1,0 | 1,31 | G26H-550 | 2x 2,6 | 1,46 | G26H-600 | 2x 2,6 | 1,56 | G26H-750 | 2x 2,6 | 1,61 |
| 1800 x 1700 | S10C-350 | 2x 1,0 | 1,18 | S10C-450 | 2x 1,0 | 1,42 | G26H-550 | 2x 2,6 | 1,57 | G26H-600 | 2x 2,6 | 1,67 | G26H-750 | 2x 2,6 | 1,72 |
| 1800 x 1800 | S10C-400 | 2x 1,0 | 1,29 | G26H-600 | 2x 2,6 | 1,54 | G26H-600 | 2x 2,6 | 1,69 | G26H-750 | 2x 2,6 | 1,78 | G40H-830 | 2x 4,0 | 1,83 |
| 1800 x 1900 | S10C-400 | 2x 1,0 | 1,40 | G26H-550 | 2x 2,6 | 1,65 | G26H-750 | 2x 2,6 | 1,80 | G26H-750 | 2x 2,6 | 1,89 | G40H-830 | 2x 4,0 | 1,94 |
| 1900 x 800 | S08B-200 | 2x 0,8 | 0,43 | S08B-300 | 2x 0,8 | 0,57 | S08B-300 | 2x 0,8 | 0,67 | S10C-400 | 2x 1,0 | 0,74 | G26G-450 | 2x 2,6 | 0,78 |
| 1900 x 900 | S08B-200 | 2x 0,8 | 0,51 | S08B-300 | 2x 0,8 | 0,66 | S10C-400 | 2x 1,0 | 0,77 | S10C-400 | 2x 1,0 | 0,85 | G26G-450 | 2x 2,6 | 0,89 |
| 1900 x 1000 | S08B-200 | 2x 0,8 | 0,58 | S10C-350 | 2x 1,0 | 0,76 | S10C-400 | 2x 1,0 | 0,88 | S10C-450 | 2x 1,0 | 0,96 | G26G-450 | 2x 2,6 | 1,01 |
| 1900 x 1100 | S08B-200 | 2x 0,8 | 0,67 | S08B-300 | 2x 0,8 | 0,86 | S10C-350 | 2x 1,0 | 0,98 | G26G-450 | 2x 2,6 | 1,07 | G26H-550 | 2x 2,6 | 1,12 |
| 1900 x 1200 | S08B-300 | 2x 0,8 | 0,75 | S10C-350 | 2x 1,0 | 0,96 | S10C-400 | 2x 1,0 | 1,09 | G26G-450 | 2x 2,6 | 1,19 | G26H-600 | 2x 2,6 | 1,24 |
| 1900 x 1300 | S10C-350 | 2x 1,0 | 0,84 | S10C-450 | 2x 1,0 | 1,06 | S10C-450 | 2x 1,0 | 1,20 | G26G-450 | 2x 2,6 | 1,30 | G26H-600 | 2x 2,6 | 1,36 |
| 1900 x 1400 | S08B-300 | 2x 0,8 | 0,94 | S10C-400 | 2x 1,0 | 1,17 | G26G-450 | 2x 2,6 | 1,32 | G26H-550 | 2x 2,6 | 1,42 | G26H-600 | 2x 2,6 | 1,47 |
| 1900 x 1500 | S08B-300 | 2x 0,8 | 1,03 | S10C-450 | 2x 1,0 | 1,27 | G26G-450 | 2x 2,6 | 1,43 | G26H-550 | 2x 2,6 | 1,53 | G26H-750 | 2x 2,6 | 1,59 |

(*) It is possible to make intermediate dimensions of the smoke exhaust window between the values given in the table. The size of the active aerodynamic area for these dimensions is determined by linear interpolation.
 (***) Smoke exhaust windows are equipped with a set of two spindle actuators. Power consumption is given for a set of two actuators.

1.1.5.1. technical specification - top- and bottom-opening smoke exhaust windows opening outwards with spindle actuators

| WINDOW SIZE* B' x H' | OPENING ANGLE 30° | | | OPENING ANGLE 45° | | | OPENING ANGLE 60° | | | OPENING ANGLE 75° | | | OPENING ANGLE 90° | | |
|-------------------------|-------------------|--------------------------|--|-------------------|--------------------------|--|-------------------|--------------------------|--|-------------------|--------------------------|--|-------------------|--------------------------|--|
| | ACTUATOR | POWER CON-SUMPTION** [A] | ACTIVE AERODYNAMIC AREA [Aa] [m ²] | ACTUATOR | POWER CON-SUMPTION** [A] | ACTIVE AERODYNAMIC AREA [Aa] [m ²] | ACTUATOR | POWER CON-SUMPTION** [A] | ACTIVE AERODYNAMIC AREA [Aa] [m ²] | ACTUATOR | POWER CON-SUMPTION** [A] | ACTIVE AERODYNAMIC AREA [Aa] [m ²] | ACTUATOR | POWER CON-SUMPTION** [A] | ACTIVE AERODYNAMIC AREA [Aa] [m ²] |
| 1900 x 1600 | S10C-350 | 2x 1,0 | 1,14 | S10C-450 | 2x 1,0 | 1,39 | G26H-550 | 2x 2,6 | 1,55 | G26H-600 | 2x 2,6 | 1,65 | G26H-750 | 2x 2,6 | 1,70 |
| 1900 x 1700 | S10C-350 | 2x 1,0 | 1,24 | S10C-450 | 2x 1,0 | 1,50 | G26H-550 | 2x 2,6 | 1,67 | G26H-600 | 2x 2,6 | 1,77 | G26H-750 | 2x 2,6 | 1,82 |
| 1900 x 1800 | S10C-400 | 2x 1,0 | 1,36 | G26H-600 | 2x 2,6 | 1,62 | G26H-600 | 2x 2,6 | 1,79 | G26H-750 | 2x 2,6 | 1,88 | G40H-830 | 2x 4,0 | 1,94 |
| 2000 x 800 | S08B-200 | 2x 0,8 | 0,45 | S08B-300 | 2x 0,8 | 0,60 | S08B-300 | 2x 0,8 | 0,70 | S10C-400 | 2x 1,0 | 0,78 | G26G-450 | 2x 2,6 | 0,82 |
| 2000 x 900 | S08B-200 | 2x 0,8 | 0,53 | S08B-300 | 2x 0,8 | 0,70 | S10C-400 | 2x 1,0 | 0,81 | S10C-400 | 2x 1,0 | 0,90 | G26G-450 | 2x 2,6 | 0,94 |
| 2000 x 1000 | S08B-200 | 2x 0,8 | 0,61 | S10C-350 | 2x 1,0 | 0,80 | S10C-400 | 2x 1,0 | 0,93 | G26G-450 | 2x 2,6 | 1,02 | G26G-450 | 2x 2,6 | 1,06 |
| 2000 x 1100 | S08B-200 | 2x 0,8 | 0,70 | S08B-300 | 2x 0,8 | 0,90 | S10C-450 | 2x 1,0 | 1,04 | G26G-450 | 2x 2,6 | 1,13 | G26H-550 | 2x 2,6 | 1,19 |
| 2000 x 1200 | S08B-300 | 2x 0,8 | 0,79 | S10C-350 | 2x 1,0 | 1,01 | S10C-400 | 2x 1,0 | 1,15 | G26G-450 | 2x 2,6 | 1,25 | G26H-600 | 2x 2,6 | 1,31 |
| 2000 x 1300 | S10C-350 | 2x 1,0 | 0,88 | S10C-450 | 2x 1,0 | 1,12 | S10C-450 | 2x 1,0 | 1,27 | G26G-450 | 2x 2,6 | 1,38 | G26H-600 | 2x 2,6 | 1,43 |
| 2000 x 1400 | S08B-300 | 2x 0,8 | 0,98 | S10C-400 | 2x 1,0 | 1,23 | G26G-450 | 2x 2,6 | 1,39 | G26H-550 | 2x 2,6 | 1,50 | G26H-600 | 2x 2,6 | 1,55 |
| 2000 x 1500 | S08B-300 | 2x 0,8 | 1,09 | S10C-450 | 2x 1,0 | 1,34 | G26G-450 | 2x 2,6 | 1,51 | G26H-550 | 2x 2,6 | 1,62 | G26H-750 | 2x 2,6 | 1,68 |
| 2000 x 1600 | S10C-350 | 2x 1,0 | 1,19 | S10C-450 | 2x 1,0 | 1,46 | G26H-550 | 2x 2,6 | 1,63 | G26H-600 | 2x 2,6 | 1,74 | G26H-750 | 2x 2,6 | 1,80 |
| 2000 x 1700 | S10C-350 | 2x 1,0 | 1,30 | S10C-450 | 2x 1,0 | 1,58 | G26H-550 | 2x 2,6 | 1,75 | G26H-600 | 2x 2,6 | 1,87 | G26H-750 | 2x 2,6 | 1,92 |
| 2100 x 800 | S08B-200 | 2x 0,8 | 0,48 | S08B-300 | 2x 0,8 | 0,64 | S08B-300 | 2x 0,8 | 0,74 | S10C-400 | 2x 1,0 | 0,82 | G26G-450 | 2x 2,6 | 0,86 |
| 2100 x 900 | S08B-200 | 2x 0,8 | 0,56 | S08B-300 | 2x 0,8 | 0,74 | S10C-400 | 2x 1,0 | 0,86 | S10C-400 | 2x 1,0 | 0,94 | G26G-450 | 2x 2,6 | 0,99 |
| 2100 x 1000 | S08B-200 | 2x 0,8 | 0,65 | S10C-350 | 2x 1,0 | 0,84 | S10C-400 | 2x 1,0 | 0,97 | G26G-450 | 2x 2,6 | 1,07 | G26G-450 | 2x 2,6 | 1,12 |
| 2100 x 1100 | S08B-200 | 2x 0,8 | 0,73 | S08B-300 | 2x 0,8 | 0,95 | S10C-450 | 2x 1,0 | 1,09 | G26G-450 | 2x 2,6 | 1,19 | G26H-550 | 2x 2,6 | 1,25 |
| 2100 x 1200 | S08B-300 | 2x 0,8 | 0,83 | S10C-350 | 2x 1,0 | 1,06 | G26G-450 | 2x 2,6 | 1,21 | G26G-450 | 2x 2,6 | 1,32 | G26H-600 | 2x 2,6 | 1,38 |
| 2100 x 1300 | S10C-350 | 2x 1,0 | 0,93 | S10C-450 | 2x 1,0 | 1,17 | G26G-450 | 2x 2,6 | 1,33 | G26G-450 | 2x 2,6 | 1,45 | G26H-600 | 2x 2,6 | 1,51 |
| 2100 x 1400 | S08B-300 | 2x 0,8 | 1,03 | S10C-400 | 2x 1,0 | 1,29 | G26G-450 | 2x 2,6 | 1,46 | G26H-550 | 2x 2,6 | 1,58 | G26H-750 | 2x 2,6 | 1,64 |
| 2100 x 1500 | S08B-300 | 2x 0,8 | 1,14 | S10C-450 | 2x 1,0 | 1,41 | G26G-450 | 2x 2,6 | 1,59 | G26H-550 | 2x 2,6 | 1,70 | G26H-750 | 2x 2,6 | 1,77 |
| 2100 x 1600 | S10C-350 | 2x 1,0 | 1,25 | S10C-450 | 2x 1,0 | 1,53 | G26H-550 | 2x 2,6 | 1,71 | G26H-600 | 2x 2,6 | 1,83 | G26H-750 | 2x 2,6 | 1,90 |
| 2200 x 800 | S08B-200 | 2x 0,8 | 0,50 | S08B-300 | 2x 0,8 | 0,67 | S08B-300 | 2x 0,8 | 0,78 | S10C-400 | 2x 1,0 | 0,86 | G26G-450 | 2x 2,6 | 0,91 |
| 2200 x 900 | S08B-200 | 2x 0,8 | 0,59 | S08B-300 | 2x 0,8 | 0,77 | S10C-400 | 2x 1,0 | 0,90 | G26G-450 | 2x 2,6 | 0,99 | G26G-450 | 2x 2,6 | 1,04 |
| 2200 x 1000 | S08B-200 | 2x 0,8 | 0,68 | S10C-350 | 2x 1,0 | 0,88 | S10C-400 | 2x 1,0 | 1,02 | G26G-450 | 2x 2,6 | 1,12 | G26G-450 | 2x 2,6 | 1,18 |
| 2200 x 1100 | S08B-200 | 2x 0,8 | 0,77 | S08B-300 | 2x 0,8 | 1,00 | S10C-450 | 2x 1,0 | 1,15 | G26G-450 | 2x 2,6 | 1,26 | G26H-550 | 2x 2,6 | 1,31 |
| 2200 x 1200 | S08B-300 | 2x 0,8 | 0,87 | S10C-350 | 2x 1,0 | 1,11 | G26G-450 | 2x 2,6 | 1,27 | G26G-450 | 2x 2,6 | 1,39 | G26H-600 | 2x 2,6 | 1,45 |
| 2200 x 1300 | S10C-350 | 2x 1,0 | 0,97 | S10C-450 | 2x 1,0 | 1,23 | G26G-450 | 2x 2,6 | 1,40 | G26G-450 | 2x 2,6 | 1,52 | G26H-600 | 2x 2,6 | 1,59 |

(*) It is possible to make intermediate dimensions of the smoke exhaust window between the values given in the table. The size of the active aerodynamic area for these dimensions is determined by linear interpolation.
 (***) Smoke exhaust windows are equipped with a set of two spindle actuators. Power consumption is given for a set of two actuators.

1.1.5.1. technical specification - top- and bottom-opening smoke exhaust windows opening outwards with spindle actuators

| WINDOW SIZE* B' x H' [mm] | OPENING ANGLE 30° | | | OPENING ANGLE 45° | | | OPENING ANGLE 60° | | | OPENING ANGLE 75° | | | OPENING ANGLE 90° | | |
|---------------------------------|-------------------|--------------------------|--|-------------------|--------------------------|--|-------------------|--------------------------|--|-------------------|--------------------------|--|-------------------|--------------------------|--|
| | ACTUATOR | POWER CON-SUMPTION** [A] | ACTIVE AERODYNAMIC AREA [Aa] [m ²] | ACTUATOR | POWER CON-SUMPTION** [A] | ACTIVE AERODYNAMIC AREA [Aa] [m ²] | ACTUATOR | POWER CON-SUMPTION** [A] | ACTIVE AERODYNAMIC AREA [Aa] [m ²] | ACTUATOR | POWER CON-SUMPTION** [A] | ACTIVE AERODYNAMIC AREA [Aa] [m ²] | ACTUATOR | POWER CON-SUMPTION** [A] | ACTIVE AERODYNAMIC AREA [Aa] [m ²] |
| 2200 x 1400 | S08B-300 | 2x0,8 | 1,08 | S10C-400 | 2x1,0 | 1,35 | G26G-450 | 2x2,6 | 1,53 | G26H-550 | 2x2,6 | 1,65 | G26H-750 | 2x2,6 | 1,72 |
| 2200 x 1500 | S08B-300 | 2x0,8 | 1,19 | S10C-450 | 2x1,0 | 1,48 | G26G-450 | 2x2,6 | 1,66 | G26H-550 | 2x2,6 | 1,79 | G26H-750 | 2x2,6 | 1,86 |
| 2200 x 1600 | S10C-350 | 2x1,0 | 1,30 | S10C-450 | 2x1,0 | 1,60 | G26H-550 | 2x2,6 | 1,80 | G26H-600 | 2x2,6 | 1,92 | G26H-750 | 2x2,6 | 1,99 |
| 2300 x 800 | S08B-200 | 2x0,8 | 0,52 | S08B-300 | 2x0,8 | 0,70 | S08B-300 | 2x0,8 | 0,82 | S10C-400 | 2x1,0 | 0,90 | G26G-450 | 2x2,6 | 0,95 |
| 2300 x 900 | S08B-200 | 2x0,8 | 0,61 | S08B-300 | 2x0,8 | 0,81 | S10C-400 | 2x1,0 | 0,94 | G26G-450 | 2x2,6 | 1,04 | G26G-450 | 2x2,6 | 1,09 |
| 2300 x 1000 | S08B-200 | 2x0,8 | 0,71 | S10C-350 | 2x1,0 | 0,92 | S10C-400 | 2x1,0 | 1,07 | G26G-450 | 2x2,6 | 1,18 | G26G-450 | 2x2,6 | 1,24 |
| 2300 x 1100 | S08B-200 | 2x0,8 | 0,80 | S08B-300 | 2x0,8 | 1,04 | S10C-450 | 2x1,0 | 1,20 | G26G-450 | 2x2,6 | 1,32 | G26H-550 | 2x2,6 | 1,38 |
| 2300 x 1200 | S08B-300 | 2x0,8 | 0,90 | S10C-350 | 2x1,0 | 1,16 | G26G-450 | 2x2,6 | 1,33 | G26G-450 | 2x2,6 | 1,45 | G26H-600 | 2x2,6 | 1,52 |
| 2300 x 1300 | S10C-350 | 2x1,0 | 1,01 | S10C-450 | 2x1,0 | 1,28 | G26G-450 | 2x2,6 | 1,47 | G26G-450 | 2x2,6 | 1,59 | G26H-600 | 2x2,6 | 1,66 |
| 2300 x 1400 | S08B-300 | 2x0,8 | 1,12 | S10C-400 | 2x1,0 | 1,41 | G26G-450 | 2x2,6 | 1,60 | G26H-550 | 2x2,6 | 1,73 | G26H-750 | 2x2,6 | 1,80 |
| 2300 x 1500 | S08B-300 | 2x0,8 | 1,24 | S10C-450 | 2x1,0 | 1,54 | G26G-450 | 2x2,6 | 1,74 | G26H-550 | 2x2,6 | 1,87 | G26H-750 | 2x2,6 | 1,95 |
| 2400 x 800 | S08B-200 | 2x0,8 | 0,55 | S08B-300 | 2x0,8 | 0,73 | S08B-300 | 2x0,8 | 0,85 | S10C-400 | 2x1,0 | 0,94 | G26G-450 | 2x2,6 | 1,00 |
| 2400 x 900 | S08B-200 | 2x0,8 | 0,64 | S08B-300 | 2x0,8 | 0,85 | S10C-400 | 2x1,0 | 0,98 | G26G-450 | 2x2,6 | 1,09 | G26G-450 | 2x2,6 | 1,14 |
| 2400 x 1000 | S08B-200 | 2x0,8 | 0,74 | S10C-350 | 2x1,0 | 0,96 | S10C-400 | 2x1,0 | 1,12 | G26G-450 | 2x2,6 | 1,23 | G26G-450 | 2x2,6 | 1,29 |
| 2400 x 1100 | S08B-200 | 2x0,8 | 0,84 | S08B-300 | 2x0,8 | 1,09 | S10C-450 | 2x1,0 | 1,25 | G26G-450 | 2x2,6 | 1,38 | G26H-550 | 2x2,6 | 1,44 |
| 2400 x 1200 | S08B-300 | 2x0,8 | 0,94 | S10C-350 | 2x1,0 | 1,21 | G26G-450 | 2x2,6 | 1,39 | G26G-450 | 2x2,6 | 1,52 | G26H-600 | 2x2,6 | 1,59 |
| 2400 x 1300 | S10C-350 | 2x1,0 | 1,05 | S10C-450 | 2x1,0 | 1,34 | G26G-450 | 2x2,6 | 1,53 | G26G-450 | 2x2,6 | 1,67 | G26H-600 | 2x2,6 | 1,74 |
| 2400 x 1400 | S08B-300 | 2x0,8 | 1,17 | S10C-400 | 2x1,0 | 1,47 | G26G-450 | 2x2,6 | 1,67 | G26H-550 | 2x2,6 | 1,81 | G26H-750 | 2x2,6 | 1,89 |
| 2500 x 800 | S08B-200 | 2x0,8 | 0,57 | S08B-300 | 2x0,8 | 0,76 | S08B-300 | 2x0,8 | 0,89 | S10C-400 | 2x1,0 | 0,99 | G26G-450 | 2x2,6 | 1,04 |
| 2500 x 900 | S08B-200 | 2x0,8 | 0,67 | S08B-300 | 2x0,8 | 0,88 | S10C-400 | 2x1,0 | 1,03 | G26G-450 | 2x2,6 | 1,14 | G26G-450 | 2x2,6 | 1,19 |
| 2500 x 1000 | S08B-200 | 2x0,8 | 0,77 | S10C-350 | 2x1,0 | 1,01 | S10C-400 | 2x1,0 | 1,17 | G26G-450 | 2x2,6 | 1,28 | G26G-450 | 2x2,6 | 1,35 |
| 2500 x 1100 | S08B-200 | 2x0,8 | 0,87 | S08B-300 | 2x0,8 | 1,13 | S10C-450 | 2x1,0 | 1,31 | G26G-450 | 2x2,6 | 1,44 | G26H-550 | 2x2,6 | 1,50 |
| 2500 x 1200 | S08B-300 | 2x0,8 | 0,98 | S10C-350 | 2x1,0 | 1,26 | G26G-450 | 2x2,6 | 1,45 | G26G-450 | 2x2,6 | 1,59 | G26H-600 | 2x2,6 | 1,66 |
| 2500 x 1300 | S10C-350 | 2x1,0 | 1,09 | S10C-450 | 2x1,0 | 1,40 | G26G-450 | 2x2,6 | 1,60 | G26G-450 | 2x2,6 | 1,74 | G26H-750 | 2x2,6 | 1,82 |
| 2500 x 1400 | S08B-300 | 2x0,8 | 1,21 | S10C-400 | 2x1,0 | 1,53 | G26G-450 | 2x2,6 | 1,74 | G26H-550 | 2x2,6 | 1,89 | G26H-750 | 2x2,6 | 1,97 |
| 2600 x 800 | S08B-200 | 2x0,8 | 0,59 | S08B-300 | 2x0,8 | 0,79 | S08B-300 | 2x0,8 | 0,93 | S10C-401 | 2x1,0 | 1,03 | G26G-450 | 2x2,6 | 1,08 |
| 2600 x 900 | S08B-200 | 2x0,8 | 0,69 | S08B-300 | 2x0,8 | 0,92 | S10C-400 | 2x1,0 | 1,07 | G26G-450 | 2x2,6 | 1,18 | G26G-450 | 2x2,6 | 1,24 |
| 2600 x 1000 | S08B-200 | 2x0,8 | 0,80 | S10C-350 | 2x1,0 | 1,05 | S10C-400 | 2x1,0 | 1,21 | G26G-450 | 2x2,6 | 1,34 | G26G-450 | 2x2,6 | 1,41 |

(*) It is possible to make intermediate dimensions of the smoke exhaust window between the values given in the table. The size of the active aerodynamic area for these dimensions is determined by linear interpolation.
 (***) Smoke exhaust windows are equipped with a set of two spindle actuators. Power consumption is given for a set of two actuators.

1.1.5.1. technical specification - top- and bottom-opening smoke exhaust windows opening outwards with spindle actuators

| WINDOW SIZE* B' x H' [mm] | OPENING ANGLE 30° | | | OPENING ANGLE 45° | | | OPENING ANGLE 60° | | | OPENING ANGLE 75° | | | OPENING ANGLE 90° | | |
|---------------------------------|-------------------|--------------------------|--|-------------------|--------------------------|--|-------------------|--------------------------|--|-------------------|--------------------------|--|-------------------|--------------------------|--|
| | ACTUATOR | POWER CON-SUMPTION** [A] | ACTIVE AERODYNAMIC AREA [Aa] [m ²] | ACTUATOR | POWER CON-SUMPTION** [A] | ACTIVE AERODYNAMIC AREA [Aa] [m ²] | ACTUATOR | POWER CON-SUMPTION** [A] | ACTIVE AERODYNAMIC AREA [Aa] [m ²] | ACTUATOR | POWER CON-SUMPTION** [A] | ACTIVE AERODYNAMIC AREA [Aa] [m ²] | ACTUATOR | POWER CON-SUMPTION** [A] | ACTIVE AERODYNAMIC AREA [Aa] [m ²] |
| 2600 x 1100 | S08B-200 | 2x0,8 | 0,90 | S08B-300 | 2x0,8 | 1,18 | S10C-450 | 2x1,0 | 1,36 | G26G-450 | 2x2,6 | 1,50 | G26H-550 | 2x2,6 | 1,57 |
| 2600 x 1200 | S08B-300 | 2x0,8 | 1,02 | S10C-350 | 2x1,0 | 1,31 | G26G-450 | 2x2,6 | 1,51 | G26G-450 | 2x2,6 | 1,65 | G26H-600 | 2x2,6 | 1,73 |
| 2600 x 1300 | S10C-350 | 2x1,0 | 1,14 | S10C-450 | 2x1,0 | 1,45 | G26G-450 | 2x2,6 | 1,66 | G26G-450 | 2x2,6 | 1,81 | G26H-750 | 2x2,6 | 1,89 |
| 2700 x 800 | S08B-200 | 2x0,8 | 0,61 | S08B-300 | 2x0,8 | 0,82 | S08B-300 | 2x0,8 | 0,96 | S10C-401 | 2x1,0 | 1,07 | G26G-450 | 2x2,6 | 1,13 |
| 2700 x 900 | S08B-200 | 2x0,8 | 0,72 | S08B-300 | 2x0,8 | 0,95 | S10C-400 | 2x1,0 | 1,11 | G26G-450 | 2x2,6 | 1,23 | G26G-450 | 2x2,6 | 1,30 |
| 2700 x 1000 | S08B-200 | 2x0,8 | 0,83 | S10C-350 | 2x1,0 | 1,09 | S10C-400 | 2x1,0 | 1,26 | G26G-450 | 2x2,6 | 1,39 | G26G-450 | 2x2,6 | 1,46 |
| 2700 x 1100 | S08B-200 | 2x0,8 | 0,94 | S08B-300 | 2x0,8 | 1,22 | S10C-450 | 2x1,0 | 1,42 | G26G-450 | 2x2,6 | 1,56 | G26H-550 | 2x2,6 | 1,63 |
| 2700 x 1200 | S08B-300 | 2x0,8 | 1,05 | S10C-350 | 2x1,0 | 1,36 | G26G-450 | 2x2,6 | 1,57 | G26G-450 | 2x2,6 | 1,72 | G26H-600 | 2x2,6 | 1,80 |
| 2700 x 1300 | S10C-350 | 2x1,0 | 1,18 | S10C-450 | 2x1,0 | 1,51 | G26G-450 | 2x2,6 | 1,73 | G26G-450 | 2x2,6 | 1,88 | G26H-750 | 2x2,6 | 1,97 |

(*) It is possible to make intermediate dimensions of the smoke exhaust window between the values given in the table. The size of the active aerodynamic area for these dimensions is determined by linear interpolation.

(**) Smoke exhaust windows are equipped with a set of two spindle actuators. Power consumption is given for a set of two actuators.

1.1.5.2. types of smoke exhaust windows opening outwards by means of chain actuators**bottom hung outward-opening windows**

Fig. 50 - mcr OSO THERM 75 smoke exhaust window with KR10B / HCV chain actuator



Fig. 51 - mcr OSO THERM 75 smoke exhaust window with two KR10B / HCV chain actuators

top-hung outward-opening windows

Fig. 52 - mcr OSO THERM 75 smoke exhaust window with KR10B / HCV chain actuator

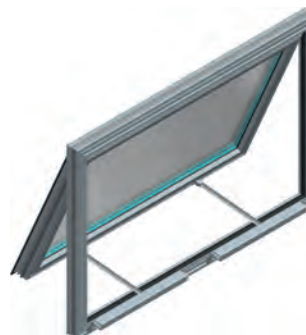


Fig. 53 - mcr OSO THERM 75 smoke exhaust window with two KR10B / HCV chain actuators

1.1.5.2. technical specification - top- and bottom-opening smoke exhaust windows opening outwards with chain actuators

| WINDOW SIZE** | ACTUATOR* | POWER CONSUMPTION FOR 24 V- / 48 V-*** | OPENING ANGLE | ACTIVE AERODYNAMIC AREA [Aa] | WINDOW SIZE** | ACTUATOR* | POWER CONSUMPTION FOR 24 V- / 48 V-*** | OPENING ANGLE | ACTIVE AERODYNAMIC AREA [Aa] |
|---------------|------------|--|---------------|------------------------------|---------------|------------|--|---------------|------------------------------|
| B' x H' | | | | | B' x H' | | | | |
| [mm] | - | [A] | [°] | [m ²] | [mm] | - | [A] | [°] | [m ²] |
| 800 x 800 | KR10B-400 | 1,0 | 34 | 0,19 | 900 x 1100 | HCV500/600 | 1,4 / 0,7 | 35 | 0,34 |
| 800 x 800 | HCV500/350 | 1,4 / 0,7 | 29 | 0,17 | 900 x 1100 | HCV500/350 | 1,4 / 0,7 | 20 | 0,24 |
| 800 x 900 | KR10B-400 | 1,0 | 29 | 0,20 | 900 x 1200 | KR10B-500 | 1,0 | 26 | 0,33 |
| 800 x 900 | HCV500/350 | 1,4 / 0,7 | 25 | 0,18 | 900 x 1200 | KR10B-400 | 1,0 | 21 | 0,28 |
| 800 x 1000 | KR10B-400 | 1,0 | 26 | 0,22 | 900 x 1200 | HCV500/600 | 1,4 / 0,7 | 32 | 0,36 |
| 800 x 1000 | HCV500/350 | 1,4 / 0,7 | 22 | 0,19 | 900 x 1200 | HCV500/350 | 1,4 / 0,7 | 18 | 0,25 |
| 800 x 1100 | KR10B-400 | 1,0 | 23 | 0,23 | 900 x 1300 | KR10B-500 | 1,0 | 24 | 0,35 |
| 800 x 1100 | HCV500/350 | 1,4 / 0,7 | 20 | 0,21 | 900 x 1300 | KR10B-400 | 1,0 | 19 | 0,30 |
| 800 x 1200 | KR10B-400 | 1,0 | 21 | 0,25 | 900 x 1300 | HCV500/600 | 1,4 / 0,7 | 29 | 0,39 |
| 800 x 1200 | HCV500/350 | 1,4 / 0,7 | 18 | 0,22 | 900 x 1300 | HCV500/350 | 1,4 / 0,7 | 17 | 0,26 |
| 800 x 1300 | KR10B-400 | 1,0 | 19 | 0,27 | 900 x 1400 | KR10B-500 | 1,0 | 22 | 0,37 |
| 800 x 1300 | HCV500/350 | 1,4 / 0,7 | 17 | 0,23 | 900 x 1400 | KR10B-400 | 1,0 | 18 | 0,32 |
| 800 x 1400 | KR10B-400 | 1,0 | 18 | 0,28 | 900 x 1400 | HCV500/600 | 1,4 / 0,7 | 27 | 0,41 |
| 800 x 1400 | HCV500/350 | 1,4 / 0,7 | 15 | 0,25 | 900 x 1400 | HCV500/350 | 1,4 / 0,7 | 15 | 0,28 |
| 800 x 1500 | KR10B-400 | 1,0 | 17 | 0,30 | 900 x 1500 | KR10B-500 | 1,0 | 21 | 0,40 |
| 800 x 1500 | HCV500/350 | 1,4 / 0,7 | 14 | 0,26 | 900 x 1500 | KR10B-400 | 1,0 | 17 | 0,33 |
| 800 x 1600 | KR10B-400 | 1,0 | 15 | 0,31 | 900 x 1500 | HCV500/600 | 1,4 / 0,7 | 25 | 0,44 |
| 800 x 1600 | HCV500/350 | 1,4 / 0,7 | 13 | 0,28 | 900 x 1500 | HCV500/350 | 1,4 / 0,7 | 14 | 0,29 |
| 800 x 1700 | KR10B-400 | 1,0 | 14 | 0,33 | 900 x 1600 | KR10B-500 | 1,0 | 19 | 0,42 |
| 800 x 1700 | HCV500/350 | 1,4 / 0,7 | 12 | 0,29 | 900 x 1600 | KR10B-400 | 1,0 | 15 | 0,35 |
| 800 x 1800 | KR10B-400 | 1,0 | 14 | 0,35 | 900 x 1600 | HCV500/600 | 1,4 / 0,7 | 23 | 0,47 |
| 800 x 1800 | HCV500/350 | 1,4 / 0,7 | 12 | 0,32 | 900 x 1600 | HCV500/350 | 1,4 / 0,7 | 13 | 0,31 |
| 800 x 1900 | KR10B-400 | 1,0 | 13 | 0,37 | 900 x 1700 | KR10B-500 | 1,0 | 18 | 0,44 |
| 800 x 1900 | HCV500/350 | 1,4 / 0,7 | 11 | 0,34 | 900 x 1700 | KR10B-400 | 1,0 | 14 | 0,37 |
| 800 x 2000 | KR10B-400 | 1,0 | 12 | 0,39 | 900 x 1700 | HCV500/600 | 1,4 / 0,7 | 22 | 0,50 |
| 800 x 2000 | HCV500/350 | 1,4 / 0,7 | 10 | 0,36 | 900 x 1700 | HCV500/350 | 1,4 / 0,7 | 12 | 0,33 |
| 800 x 2100 | KR10B-400 | 1,0 | 12 | 0,42 | 900 x 1800 | KR10B-500 | 1,0 | 17 | 0,47 |
| 800 x 2100 | HCV500/350 | 1,4 / 0,7 | 10 | 0,28 | 900 x 1800 | KR10B-400 | 1,0 | 14 | 0,39 |
| 800 x 2200 | KR10B-400 | 1,0 | 11 | 0,45 | 900 x 1800 | HCV500/600 | 1,4 / 0,7 | 20 | 0,53 |
| 800 x 2200 | HCV500/350 | 1,4 / 0,7 | 9 | 0,29 | 900 x 1800 | HCV500/350 | 1,4 / 0,7 | 12 | 0,35 |
| 900 x 800 | KR10B-500 | 1,0 | 42 | 0,25 | 900 x 1900 | KR10B-500 | 1,0 | 16 | 0,49 |
| 900 x 800 | KR10B-400 | 1,0 | 34 | 0,21 | 900 x 1900 | KR10B-400 | 1,0 | 13 | 0,42 |
| 900 x 800 | HCV500/600 | 1,4 / 0,7 | 51 | 0,27 | 900 x 1900 | HCV500/600 | 1,4 / 0,7 | 19 | 0,56 |
| 900 x 800 | HCV500/350 | 1,4 / 0,7 | 29 | 0,19 | 900 x 1900 | HCV500/350 | 1,4 / 0,7 | 11 | 0,38 |
| 900 x 900 | KR10B-500 | 1,0 | 37 | 0,27 | 900 x 2000 | KR10B-500 | 1,0 | 15 | 0,52 |
| 900 x 900 | KR10B-400 | 1,0 | 29 | 0,23 | 900 x 2000 | KR10B-400 | 1,0 | 12 | 0,44 |
| 900 x 900 | HCV500/600 | 1,4 / 0,7 | 44 | 0,29 | 900 x 2000 | HCV500/600 | 1,4 / 0,7 | 18 | 0,59 |
| 900 x 900 | HCV500/350 | 1,4 / 0,7 | 25 | 0,20 | 900 x 2000 | HCV500/350 | 1,4 / 0,7 | 10 | 0,40 |
| 900 x 1000 | KR10B-500 | 1,0 | 33 | 0,29 | 900 x 2100 | KR10B-500 | 1,0 | 14 | 0,55 |
| 900 x 1000 | KR10B-400 | 1,0 | 26 | 0,25 | 900 x 2100 | KR10B-400 | 1,0 | 12 | 0,47 |
| 900 x 1000 | HCV500/600 | 1,4 / 0,7 | 39 | 0,32 | 900 x 2100 | HCV500/600 | 1,4 / 0,7 | 17 | 0,62 |
| 900 x 1000 | HCV500/350 | 1,4 / 0,7 | 22 | 0,22 | 900 x 2100 | HCV500/350 | 1,4 / 0,7 | 10 | 0,32 |
| 900 x 1100 | KR10B-500 | 1,0 | 29 | 0,31 | 900 x 2200 | KR10B-500 | 1,0 | 14 | 0,58 |
| 900 x 1100 | KR10B-400 | 1,0 | 23 | 0,26 | 900 x 2200 | KR10B-400 | 1,0 | 11 | 0,50 |

1.1.5.2. technical specification - top- and bottom-opening smoke exhaust windows opening outwards with chain actuators

| WINDOW SIZE** | ACTUATOR* | POWER CONSUMPTION FOR 24 V- / 48 V-*** | OPENING ANGLE | ACTIVE AERODYNAMIC AREA [Aa] |
|---------------|------------|--|---------------|------------------------------|
| B' x H' | | | | |
| [mm] | - | [A] | [°] | [m ²] |
| 900 x 2200 | HCV500/600 | 1,4 / 0,7 | 16 | 0,64 |
| 900 x 2200 | HCV500/350 | 1,4 / 0,7 | 9 | 0,33 |
| 1000 x 800 | KR10B-500 | 1,0 | 42 | 0,28 |
| 1000 x 800 | KR10B-400 | 1,0 | 34 | 0,24 |
| 1000 x 800 | HCV500/600 | 1,4 / 0,7 | 51 | 0,30 |
| 1000 x 800 | HCV500/350 | 1,4 / 0,7 | 29 | 0,21 |
| 1000 x 900 | KR10B-500 | 1,0 | 37 | 0,30 |
| 1000 x 900 | KR10B-400 | 1,0 | 29 | 0,26 |
| 1000 x 900 | HCV500/600 | 1,4 / 0,7 | 44 | 0,33 |
| 1000 x 900 | HCV500/350 | 1,4 / 0,7 | 25 | 0,23 |
| 1000 x 1000 | KR10B-600 | 1,0 | 39 | 0,36 |
| 1000 x 1000 | KR10B-500 | 1,0 | 33 | 0,32 |
| 1000 x 1000 | KR10B-400 | 1,0 | 26 | 0,28 |
| 1000 x 1000 | HCV500/600 | 1,4 / 0,7 | 39 | 0,36 |
| 1000 x 1000 | HCV500/350 | 1,4 / 0,7 | 22 | 0,25 |
| 1000 x 1100 | KR10B-600 | 1,0 | 35 | 0,38 |
| 1000 x 1100 | KR10B-500 | 1,0 | 29 | 0,34 |
| 1000 x 1100 | KR10B-400 | 1,0 | 23 | 0,29 |
| 1000 x 1100 | HCV500/600 | 1,4 / 0,7 | 35 | 0,38 |
| 1000 x 1100 | HCV500/350 | 1,4 / 0,7 | 20 | 0,27 |
| 1000 x 1200 | KR10B-600 | 1,0 | 32 | 0,41 |
| 1000 x 1200 | KR10B-500 | 1,0 | 26 | 0,36 |
| 1000 x 1200 | KR10B-400 | 1,0 | 21 | 0,32 |
| 1000 x 1200 | HCV500/600 | 1,4 / 0,7 | 32 | 0,41 |
| 1000 x 1200 | HCV500/350 | 1,4 / 0,7 | 18 | 0,28 |
| 1000 x 1300 | KR10B-600 | 1,0 | 29 | 0,44 |
| 1000 x 1300 | KR10B-500 | 1,0 | 24 | 0,39 |
| 1000 x 1300 | KR10B-400 | 1,0 | 19 | 0,34 |
| 1000 x 1300 | HCV500/600 | 1,4 / 0,7 | 29 | 0,44 |
| 1000 x 1300 | HCV500/350 | 1,4 / 0,7 | 17 | 0,29 |
| 1000 x 1400 | KR10B-600 | 1,0 | 27 | 0,46 |
| 1000 x 1400 | KR10B-500 | 1,0 | 22 | 0,41 |
| 1000 x 1400 | KR10B-400 | 1,0 | 18 | 0,35 |
| 1000 x 1400 | HCV500/600 | 1,4 / 0,7 | 27 | 0,46 |
| 1000 x 1400 | HCV500/350 | 1,4 / 0,7 | 15 | 0,31 |
| 1000 x 1500 | KR10B-600 | 1,0 | 25 | 0,49 |
| 1000 x 1500 | KR10B-500 | 1,0 | 21 | 0,44 |
| 1000 x 1500 | KR10B-400 | 1,0 | 17 | 0,37 |
| 1000 x 1500 | HCV500/600 | 1,4 / 0,7 | 25 | 0,49 |
| 1000 x 1500 | HCV500/350 | 1,4 / 0,7 | 14 | 0,32 |
| 1000 x 1600 | KR10B-600 | 1,0 | 23 | 0,53 |
| 1000 x 1600 | KR10B-500 | 1,0 | 19 | 0,47 |
| 1000 x 1600 | KR10B-400 | 1,0 | 15 | 0,39 |
| 1000 x 1600 | HCV500/600 | 1,4 / 0,7 | 23 | 0,52 |

| WINDOW SIZE** | ACTUATOR* | POWER CONSUMPTION FOR 24 V- / 48 V-*** | OPENING ANGLE | ACTIVE AERODYNAMIC AREA [Aa] |
|---------------|------------|--|---------------|------------------------------|
| B' x H' | | | | |
| [mm] | - | [A] | [°] | [m ²] |
| 1000 x 1600 | HCV500/350 | 1,4 / 0,7 | 13 | 0,34 |
| 1000 x 1700 | KR10B-600 | 1,0 | 22 | 0,56 |
| 1000 x 1700 | KR10B-500 | 1,0 | 18 | 0,49 |
| 1000 x 1700 | KR10B-400 | 1,0 | 14 | 0,41 |
| 1000 x 1700 | HCV500/600 | 1,4 / 0,7 | 22 | 0,56 |
| 1000 x 1700 | HCV500/350 | 1,4 / 0,7 | 12 | 0,37 |
| 1000 x 1800 | KR10B-600 | 1,0 | 20 | 0,59 |
| 1000 x 1800 | KR10B-500 | 1,0 | 17 | 0,52 |
| 1000 x 1800 | KR10B-400 | 1,0 | 14 | 0,43 |
| 1000 x 1800 | HCV500/600 | 1,4 / 0,7 | 20 | 0,59 |
| 1000 x 1800 | HCV500/350 | 1,4 / 0,7 | 12 | 0,39 |
| 1000 x 1900 | KR10B-600 | 1,0 | 19 | 0,63 |
| 1000 x 1900 | KR10B-500 | 1,0 | 16 | 0,54 |
| 1000 x 1900 | KR10B-400 | 1,0 | 13 | 0,46 |
| 1000 x 1900 | HCV500/600 | 1,4 / 0,7 | 19 | 0,62 |
| 1000 x 1900 | HCV500/350 | 1,4 / 0,7 | 11 | 0,42 |
| 1000 x 2000 | KR10B-600 | 1,0 | 18 | 0,66 |
| 1000 x 2000 | KR10B-500 | 1,0 | 15 | 0,57 |
| 1000 x 2000 | KR10B-400 | 1,0 | 12 | 0,49 |
| 1000 x 2000 | HCV500/600 | 1,4 / 0,7 | 18 | 0,65 |
| 1000 x 2000 | HCV500/350 | 1,4 / 0,7 | 10 | 0,44 |
| 1000 x 2100 | KR10B-600 | 1,0 | 17 | 0,69 |
| 1000 x 2100 | KR10B-500 | 1,0 | 14 | 0,60 |
| 1000 x 2100 | KR10B-400 | 1,0 | 12 | 0,52 |
| 1000 x 2100 | HCV500/600 | 1,4 / 0,7 | 17 | 0,68 |
| 1000 x 2100 | HCV500/350 | 1,4 / 0,7 | 10 | 0,36 |
| 1000 x 2200 | KR10B-600 | 1,0 | 17 | 0,75 |
| 1000 x 2200 | KR10B-500 | 1,0 | 14 | 0,66 |
| 1000 x 2200 | KR10B-400 | 1,0 | 12 | 0,57 |
| 1000 x 2200 | HCV500/600 | 1,4 / 0,7 | 16 | 0,72 |
| 1000 x 2200 | HCV500/350 | 1,4 / 0,7 | 9 | 0,38 |
| 1100 x 800 | KR10B-500 | 1,0 | 42 | 0,31 |
| 1100 x 800 | KR10B-400 | 1,0 | 34 | 0,27 |
| 1100 x 800 | HCV500/800 | 1,4 / 0,7 | 70 | 0,39 |
| 1100 x 800 | HCV500/600 | 1,4 / 0,7 | 51 | 0,34 |
| 1100 x 800 | HCV500/350 | 1,4 / 0,7 | 29 | 0,24 |
| 1100 x 900 | KR10B-500 | 1,0 | 37 | 0,33 |
| 1100 x 900 | KR10B-400 | 1,0 | 29 | 0,29 |
| 1100 x 900 | HCV500/800 | 1,4 / 0,7 | 60 | 0,43 |
| 1100 x 900 | HCV500/600 | 1,4 / 0,7 | 44 | 0,37 |
| 1100 x 900 | HCV500/350 | 1,4 / 0,7 | 25 | 0,26 |
| 1100 x 1000 | KR10B-500 | 1,0 | 33 | 0,35 |
| 1100 x 1000 | KR10B-400 | 1,0 | 26 | 0,30 |
| 1100 x 1000 | HCV500/800 | 1,4 / 0,7 | 53 | 0,46 |

1.1.5.2. technical specification - top- and bottom-opening smoke exhaust windows opening outwards with chain actuators

| WINDOW SIZE** | ACTUATOR* | POWER CONSUMPTION FOR 24 V- / 48 V-*** | OPENING ANGLE | ACTIVE AERODYNAMIC AREA [Aa] |
|---------------|------------|--|---------------|------------------------------|
| B' x H' | | | | |
| [mm] | - | [A] | [°] | [m ²] |
| 1100 x 1000 | HCV500/600 | 1,4 / 0,7 | 39 | 0,40 |
| 1100 x 1000 | HCV500/350 | 1,4 / 0,7 | 22 | 0,27 |
| 1100 x 1100 | KR10B-500 | 1,0 | 29 | 0,38 |
| 1100 x 1100 | KR10B-400 | 1,0 | 23 | 0,32 |
| 1100 x 1100 | HCV500/800 | 1,4 / 0,7 | 47 | 0,49 |
| 1100 x 1100 | HCV500/600 | 1,4 / 0,7 | 35 | 0,42 |
| 1100 x 1100 | HCV500/350 | 1,4 / 0,7 | 20 | 0,29 |
| 1100 x 1200 | KR10B-500 | 1,0 | 26 | 0,40 |
| 1100 x 1200 | KR10B-400 | 1,0 | 21 | 0,35 |
| 1100 x 1200 | HCV500/800 | 1,4 / 0,7 | 43 | 0,53 |
| 1100 x 1200 | HCV500/600 | 1,4 / 0,7 | 32 | 0,45 |
| 1100 x 1200 | HCV500/350 | 1,4 / 0,7 | 18 | 0,31 |
| 1100 x 1300 | KR10B-600 | 1,0 | 29 | 0,48 |
| 1100 x 1300 | KR10B-500 | 1,0 | 24 | 0,43 |
| 1100 x 1300 | KR10B-400 | 1,0 | 19 | 0,37 |
| 1100 x 1300 | HCV500/800 | 1,4 / 0,7 | 39 | 0,56 |
| 1100 x 1300 | HCV500/600 | 1,4 / 0,7 | 29 | 0,48 |
| 1100 x 1300 | HCV500/350 | 1,4 / 0,7 | 17 | 0,32 |
| 1100 x 1400 | KR10B-600 | 1,0 | 27 | 0,51 |
| 1100 x 1400 | KR10B-500 | 1,0 | 22 | 0,46 |
| 1100 x 1400 | KR10B-400 | 1,0 | 18 | 0,39 |
| 1100 x 1400 | HCV500/800 | 1,4 / 0,7 | 36 | 0,60 |
| 1100 x 1400 | HCV500/600 | 1,4 / 0,7 | 27 | 0,51 |
| 1100 x 1400 | HCV500/350 | 1,4 / 0,7 | 15 | 0,34 |
| 1100 x 1500 | KR10B-600 | 1,0 | 25 | 0,54 |
| 1100 x 1500 | KR10B-500 | 1,0 | 21 | 0,49 |
| 1100 x 1500 | KR10B-400 | 1,0 | 17 | 0,41 |
| 1100 x 1500 | HCV500/800 | 1,4 / 0,7 | 33 | 0,64 |
| 1100 x 1500 | HCV500/600 | 1,4 / 0,7 | 25 | 0,54 |
| 1100 x 1500 | HCV500/350 | 1,4 / 0,7 | 14 | 0,35 |
| 1100 x 1600 | KR10B-600 | 1,0 | 23 | 0,58 |
| 1100 x 1600 | KR10B-500 | 1,0 | 19 | 0,52 |
| 1100 x 1600 | KR10B-400 | 1,0 | 15 | 0,43 |
| 1100 x 1600 | HCV500/800 | 1,4 / 0,7 | 31 | 0,68 |
| 1100 x 1600 | HCV500/600 | 1,4 / 0,7 | 23 | 0,58 |
| 1100 x 1600 | HCV500/350 | 1,4 / 0,7 | 13 | 0,38 |
| 1100 x 1700 | KR10B-600 | 1,0 | 22 | 0,61 |
| 1100 x 1700 | KR10B-500 | 1,0 | 18 | 0,54 |
| 1100 x 1700 | KR10B-400 | 1,0 | 14 | 0,45 |
| 1100 x 1700 | HCV500/800 | 1,4 / 0,7 | 29 | 0,72 |
| 1100 x 1700 | HCV500/600 | 1,4 / 0,7 | 22 | 0,61 |
| 1100 x 1700 | HCV500/350 | 1,4 / 0,7 | 12 | 0,40 |
| 1100 x 1800 | KR10B-600 | 1,0 | 20 | 0,65 |
| 1100 x 1800 | KR10B-500 | 1,0 | 17 | 0,57 |

| WINDOW SIZE** | ACTUATOR* | POWER CONSUMPTION FOR 24 V- / 48 V-*** | OPENING ANGLE | ACTIVE AERODYNAMIC AREA [Aa] |
|---------------|------------|--|---------------|------------------------------|
| B' x H' | | | | |
| [mm] | - | [A] | [°] | [m ²] |
| 1100 x 1800 | KR10B-400 | 1,0 | 14 | 0,48 |
| 1100 x 1800 | HCV500/800 | 1,4 / 0,7 | 27 | 0,76 |
| 1100 x 1800 | HCV500/600 | 1,4 / 0,7 | 20 | 0,65 |
| 1100 x 1800 | HCV500/350 | 1,4 / 0,7 | 12 | 0,42 |
| 1100 x 1900 | KR10B-600 | 1,0 | 19 | 0,69 |
| 1100 x 1900 | KR10B-500 | 1,0 | 16 | 0,60 |
| 1100 x 1900 | KR10B-400 | 1,0 | 13 | 0,50 |
| 1100 x 1900 | HCV500/800 | 1,4 / 0,7 | 26 | 0,80 |
| 1100 x 1900 | HCV500/600 | 1,4 / 0,7 | 19 | 0,68 |
| 1100 x 1900 | HCV500/350 | 1,4 / 0,7 | 11 | 0,45 |
| 1100 x 2000 | KR10B-600 | 1,0 | 18 | 0,72 |
| 1100 x 2000 | KR10B-500 | 1,0 | 15 | 0,63 |
| 1100 x 2000 | KR10B-400 | 1,0 | 12 | 0,53 |
| 1100 x 2000 | HCV500/800 | 1,4 / 0,7 | 24 | 0,84 |
| 1100 x 2000 | HCV500/600 | 1,4 / 0,7 | 18 | 0,71 |
| 1100 x 2000 | HCV500/350 | 1,4 / 0,7 | 10 | 0,48 |
| 1100 x 2100 | KR10B-600 | 1,0 | 17 | 0,75 |
| 1100 x 2100 | KR10B-500 | 1,0 | 14 | 0,66 |
| 1100 x 2100 | KR10B-400 | 1,0 | 12 | 0,57 |
| 1100 x 2100 | HCV500/800 | 1,4 / 0,7 | 23 | 0,89 |
| 1100 x 2100 | HCV500/600 | 1,4 / 0,7 | 17 | 0,75 |
| 1100 x 2100 | HCV500/350 | 1,4 / 0,7 | 10 | 0,40 |
| 1100 x 2200 | KR10B-600 | 1,0 | 17 | 0,82 |
| 1100 x 2200 | KR10B-500 | 1,0 | 14 | 0,72 |
| 1100 x 2200 | KR10B-400 | 1,0 | 12 | 0,62 |
| 1100 x 2200 | HCV500/800 | 1,4 / 0,7 | 22 | 0,95 |
| 1100 x 2200 | HCV500/600 | 1,4 / 0,7 | 16 | 0,79 |
| 1100 x 2200 | HCV500/350 | 1,4 / 0,7 | 9 | 0,42 |
| 1200 x 800 | KR10B-400 | 1,0 | 34 | 0,29 |
| 1200 x 800 | HCV500/800 | 1,4 / 0,7 | 70 | 0,44 |
| 1200 x 800 | HCV500/600 | 1,4 / 0,7 | 51 | 0,38 |
| 1200 x 800 | HCV500/350 | 1,4 / 0,7 | 29 | 0,26 |
| 1200 x 900 | KR10B-500 | 1,0 | 37 | 0,36 |
| 1200 x 900 | KR10B-400 | 1,0 | 29 | 0,31 |
| 1200 x 900 | HCV500/800 | 1,4 / 0,7 | 60 | 0,47 |
| 1200 x 900 | HCV500/600 | 1,4 / 0,7 | 44 | 0,40 |
| 1200 x 900 | HCV500/350 | 1,4 / 0,7 | 25 | 0,28 |
| 1200 x 1000 | KR10B-500 | 1,0 | 33 | 0,39 |
| 1200 x 1000 | KR10B-400 | 1,0 | 26 | 0,33 |
| 1200 x 1000 | HCV500/800 | 1,4 / 0,7 | 53 | 0,51 |
| 1200 x 1000 | HCV500/600 | 1,4 / 0,7 | 39 | 0,44 |
| 1200 x 1000 | HCV500/350 | 1,4 / 0,7 | 22 | 0,30 |
| 1200 x 1100 | KR10B-500 | 1,0 | 29 | 0,41 |
| 1200 x 1100 | KR10B-400 | 1,0 | 23 | 0,36 |

1.1.5.2. technical specification - top- and bottom-opening smoke exhaust windows opening outwards with chain actuators

| WINDOW SIZE** | ACTUATOR* | POWER CONSUMPTION FOR 24 V- / 48 V-*** | OPENING ANGLE | ACTIVE AERODYNAMIC AREA [Aa] |
|---------------|------------|--|---------------|------------------------------|
| B' x H' | | | | |
| [mm] | - | [A] | [°] | [m ²] |
| 1200 x 1100 | HCV500/800 | 1,4 / 0,7 | 47 | 0,54 |
| 1200 x 1100 | HCV500/600 | 1,4 / 0,7 | 35 | 0,46 |
| 1200 x 1100 | HCV500/350 | 1,4 / 0,7 | 20 | 0,32 |
| 1200 x 1200 | KR10B-500 | 1,0 | 26 | 0,44 |
| 1200 x 1200 | KR10B-400 | 1,0 | 21 | 0,38 |
| 1200 x 1200 | HCV500/800 | 1,4 / 0,7 | 43 | 0,58 |
| 1200 x 1200 | HCV500/600 | 1,4 / 0,7 | 32 | 0,49 |
| 1200 x 1200 | HCV500/350 | 1,4 / 0,7 | 18 | 0,33 |
| 1200 x 1300 | KR10B-500 | 1,0 | 24 | 0,47 |
| 1200 x 1300 | KR10B-400 | 1,0 | 19 | 0,40 |
| 1200 x 1300 | HCV500/800 | 1,4 / 0,7 | 39 | 0,62 |
| 1200 x 1300 | HCV500/600 | 1,4 / 0,7 | 29 | 0,52 |
| 1200 x 1300 | HCV500/350 | 1,4 / 0,7 | 17 | 0,35 |
| 1200 x 1400 | KR10B-500 | 1,0 | 22 | 0,50 |
| 1200 x 1400 | KR10B-400 | 1,0 | 18 | 0,42 |
| 1200 x 1400 | HCV500/800 | 1,4 / 0,7 | 36 | 0,66 |
| 1200 x 1400 | HCV500/600 | 1,4 / 0,7 | 27 | 0,55 |
| 1200 x 1400 | HCV500/350 | 1,4 / 0,7 | 15 | 0,36 |
| 1200 x 1500 | KR10B-500 | 1,0 | 21 | 0,53 |
| 1200 x 1500 | KR10B-400 | 1,0 | 17 | 0,44 |
| 1200 x 1500 | HCV500/800 | 1,4 / 0,7 | 33 | 0,70 |
| 1200 x 1500 | HCV500/600 | 1,4 / 0,7 | 25 | 0,59 |
| 1200 x 1500 | HCV500/350 | 1,4 / 0,7 | 14 | 0,38 |
| 1200 x 1600 | KR10B-500 | 1,0 | 19 | 0,56 |
| 1200 x 1600 | KR10B-400 | 1,0 | 15 | 0,46 |
| 1200 x 1600 | HCV500/800 | 1,4 / 0,7 | 31 | 0,74 |
| 1200 x 1600 | HCV500/600 | 1,4 / 0,7 | 23 | 0,62 |
| 1200 x 1600 | HCV500/350 | 1,4 / 0,7 | 13 | 0,40 |
| 1200 x 1700 | KR10B-600 | 1,0 | 22 | 0,67 |
| 1200 x 1700 | KR10B-500 | 1,0 | 18 | 0,59 |
| 1200 x 1700 | KR10B-400 | 1,0 | 14 | 0,49 |
| 1200 x 1700 | HCV500/800 | 1,4 / 0,7 | 29 | 0,78 |
| 1200 x 1700 | HCV500/600 | 1,4 / 0,7 | 22 | 0,66 |
| 1200 x 1700 | HCV500/350 | 1,4 / 0,7 | 12 | 0,43 |
| 1200 x 1800 | KR10B-600 | 1,0 | 20 | 0,71 |
| 1200 x 1800 | KR10B-500 | 1,0 | 17 | 0,62 |
| 1200 x 1800 | KR10B-400 | 1,0 | 14 | 0,52 |
| 1200 x 1800 | HCV500/800 | 1,4 / 0,7 | 27 | 0,83 |
| 1200 x 1800 | HCV500/600 | 1,4 / 0,7 | 20 | 0,71 |
| 1200 x 1800 | HCV500/350 | 1,4 / 0,7 | 12 | 0,46 |
| 1200 x 1900 | KR10B-600 | 1,0 | 19 | 0,75 |
| 1200 x 1900 | KR10B-500 | 1,0 | 16 | 0,64 |
| 1200 x 1900 | KR10B-400 | 1,0 | 13 | 0,54 |
| 1200 x 1900 | HCV500/800 | 1,4 / 0,7 | 26 | 0,87 |

| WINDOW SIZE** | ACTUATOR* | POWER CONSUMPTION FOR 24 V- / 48 V-*** | OPENING ANGLE | ACTIVE AERODYNAMIC AREA [Aa] |
|---------------|-------------|--|---------------|------------------------------|
| B' x H' | | | | |
| [mm] | - | [A] | [°] | [m ²] |
| 1200 x 1900 | HCV500/600 | 1,4 / 0,7 | 19 | 0,74 |
| 1200 x 1900 | HCV500/350 | 1,4 / 0,7 | 11 | 0,49 |
| 1200 x 2000 | KR10B-600 | 1,0 | 18 | 0,78 |
| 1200 x 2000 | KR10B-500 | 1,0 | 15 | 0,68 |
| 1200 x 2000 | KR10B-400 | 1,0 | 12 | 0,58 |
| 1200 x 2000 | HCV500/800 | 1,4 / 0,7 | 24 | 0,92 |
| 1200 x 2000 | HCV500/600 | 1,4 / 0,7 | 18 | 0,77 |
| 1200 x 2000 | HCV500/350 | 1,4 / 0,7 | 10 | 0,52 |
| 1200 x 2100 | KR10B-600 | 1,0 | 17 | 0,82 |
| 1200 x 2100 | KR10B-500 | 1,0 | 14 | 0,72 |
| 1200 x 2100 | KR10B-400 | 1,0 | 12 | 0,61 |
| 1200 x 2100 | HCV500/800 | 1,4 / 0,7 | 23 | 0,97 |
| 1200 x 2100 | HCV500/600 | 1,4 / 0,7 | 17 | 0,81 |
| 1200 x 2100 | HCV500/350 | 1,4 / 0,7 | 10 | 0,32 |
| 1200 x 2200 | KR10B-600 | 1,0 | 17 | 0,89 |
| 1200 x 2200 | KR10B-500 | 1,0 | 14 | 0,78 |
| 1200 x 2200 | KR10B-400 | 1,0 | 12 | 0,67 |
| 1200 x 2200 | HCV500/800 | 1,4 / 0,7 | 22 | 1,03 |
| 1200 x 2200 | HCV500/600 | 1,4 / 0,7 | 16 | 0,85 |
| 1200 x 2200 | HCV500/350 | 1,4 / 0,7 | 9 | 0,33 |
| 1300 x 800 | KR10B-400 | 1,0 | 34 | 0,32 |
| 1300 x 800 | HCV500/1000 | 1,4 / 0,7 | 92 | 0,51 |
| 1300 x 800 | HCV500/800 | 1,4 / 0,7 | 70 | 0,47 |
| 1300 x 800 | HCV500/600 | 1,4 / 0,7 | 51 | 0,41 |
| 1300 x 800 | HCV500/350 | 1,4 / 0,7 | 29 | 0,28 |
| 1300 x 900 | KR10B-400 | 1,0 | 29 | 0,34 |
| 1300 x 900 | HCV500/1000 | 1,4 / 0,7 | 78 | 0,57 |
| 1300 x 900 | HCV500/800 | 1,4 / 0,7 | 60 | 0,51 |
| 1300 x 900 | HCV500/600 | 1,4 / 0,7 | 44 | 0,44 |
| 1300 x 900 | HCV500/350 | 1,4 / 0,7 | 25 | 0,30 |
| 1300 x 1000 | KR10B-400 | 1,0 | 26 | 0,36 |
| 1300 x 1000 | HCV500/1000 | 1,4 / 0,7 | 68 | 0,62 |
| 1300 x 1000 | HCV500/800 | 1,4 / 0,7 | 53 | 0,55 |
| 1300 x 1000 | HCV500/600 | 1,4 / 0,7 | 39 | 0,48 |
| 1300 x 1000 | HCV500/350 | 1,4 / 0,7 | 22 | 0,32 |
| 1300 x 1100 | KR10B-500 | 1,0 | 29 | 0,45 |
| 1300 x 1100 | KR10B-400 | 1,0 | 23 | 0,38 |
| 1300 x 1100 | HCV500/1000 | 1,4 / 0,7 | 60 | 0,66 |
| 1300 x 1100 | HCV500/800 | 1,4 / 0,7 | 47 | 0,59 |
| 1300 x 1100 | HCV500/600 | 1,4 / 0,7 | 35 | 0,50 |
| 1300 x 1100 | HCV500/350 | 1,4 / 0,7 | 20 | 0,35 |
| 1300 x 1200 | KR10B-500 | 1,0 | 26 | 0,47 |
| 1300 x 1200 | KR10B-400 | 1,0 | 21 | 0,41 |
| 1300 x 1200 | HCV500/1000 | 1,4 / 0,7 | 54 | 0,70 |

1.1.5.2. technical specification - top- and bottom-opening smoke exhaust windows opening outwards with chain actuators

| WINDOW SIZE** | ACTUATOR* | POWER CONSUMPTION FOR 24 V- / 48 V-*** | OPENING ANGLE | ACTIVE AERODYNAMIC AREA [Aa] |
|---------------|-------------|--|---------------|------------------------------|
| B' x H' | | | | |
| [mm] | - | [A] | [°] | [m ²] |
| 1300 x 1200 | HCV500/800 | 1,4 / 0,7 | 43 | 0,63 |
| 1300 x 1200 | HCV500/600 | 1,4 / 0,7 | 32 | 0,53 |
| 1300 x 1200 | HCV500/350 | 1,4 / 0,7 | 18 | 0,36 |
| 1300 x 1300 | KR10B-500 | 1,0 | 24 | 0,51 |
| 1300 x 1300 | KR10B-400 | 1,0 | 19 | 0,44 |
| 1300 x 1300 | HCV500/1000 | 1,4 / 0,7 | 49 | 0,75 |
| 1300 x 1300 | HCV500/800 | 1,4 / 0,7 | 39 | 0,67 |
| 1300 x 1300 | HCV500/600 | 1,4 / 0,7 | 29 | 0,57 |
| 1300 x 1300 | HCV500/350 | 1,4 / 0,7 | 17 | 0,37 |
| 1300 x 1400 | KR10B-500 | 1,0 | 22 | 0,54 |
| 1300 x 1400 | KR10B-400 | 1,0 | 18 | 0,45 |
| 1300 x 1400 | HCV500/1000 | 1,4 / 0,7 | 45 | 0,80 |
| 1300 x 1400 | HCV500/800 | 1,4 / 0,7 | 36 | 0,71 |
| 1300 x 1400 | HCV500/600 | 1,4 / 0,7 | 27 | 0,60 |
| 1300 x 1400 | HCV500/350 | 1,4 / 0,7 | 15 | 0,39 |
| 1300 x 1500 | KR10B-500 | 1,0 | 21 | 0,57 |
| 1300 x 1500 | KR10B-400 | 1,0 | 17 | 0,47 |
| 1300 x 1500 | HCV500/1000 | 1,4 / 0,7 | 42 | 0,84 |
| 1300 x 1500 | HCV500/800 | 1,4 / 0,7 | 33 | 0,75 |
| 1300 x 1500 | HCV500/600 | 1,4 / 0,7 | 25 | 0,63 |
| 1300 x 1500 | HCV500/350 | 1,4 / 0,7 | 14 | 0,41 |
| 1300 x 1600 | KR10B-500 | 1,0 | 19 | 0,61 |
| 1300 x 1600 | KR10B-400 | 1,0 | 15 | 0,50 |
| 1300 x 1600 | HCV500/1000 | 1,4 / 0,7 | 39 | 0,90 |
| 1300 x 1600 | HCV500/800 | 1,4 / 0,7 | 31 | 0,80 |
| 1300 x 1600 | HCV500/600 | 1,4 / 0,7 | 23 | 0,67 |
| 1300 x 1600 | HCV500/350 | 1,4 / 0,7 | 13 | 0,44 |
| 1300 x 1700 | KR10B-500 | 1,0 | 18 | 0,63 |
| 1300 x 1700 | KR10B-400 | 1,0 | 14 | 0,52 |
| 1300 x 1700 | HCV500/1000 | 1,4 / 0,7 | 36 | 0,95 |
| 1300 x 1700 | HCV500/800 | 1,4 / 0,7 | 29 | 0,85 |
| 1300 x 1700 | HCV500/600 | 1,4 / 0,7 | 22 | 0,72 |
| 1300 x 1700 | HCV500/350 | 1,4 / 0,7 | 12 | 0,46 |
| 1300 x 1800 | KR10B-500 | 1,0 | 17 | 0,66 |
| 1300 x 1800 | KR10B-400 | 1,0 | 14 | 0,55 |
| 1300 x 1800 | HCV500/1000 | 1,4 / 0,7 | 34 | 1,00 |
| 1300 x 1800 | HCV500/800 | 1,4 / 0,7 | 27 | 0,89 |
| 1300 x 1800 | HCV500/600 | 1,4 / 0,7 | 20 | 0,76 |
| 1300 x 1800 | HCV500/350 | 1,4 / 0,7 | 12 | 0,49 |
| 1300 x 1900 | KR10B-500 | 1,0 | 16 | 0,69 |
| 1300 x 1900 | KR10B-400 | 1,0 | 13 | 0,58 |
| 1300 x 1900 | HCV500/1000 | 1,4 / 0,7 | 32 | 1,06 |
| 1300 x 1900 | HCV500/800 | 1,4 / 0,7 | 26 | 0,94 |
| 1300 x 1900 | HCV500/600 | 1,4 / 0,7 | 19 | 0,80 |

| WINDOW SIZE** | ACTUATOR* | POWER CONSUMPTION FOR 24 V- / 48 V-*** | OPENING ANGLE | ACTIVE AERODYNAMIC AREA [Aa] |
|---------------|-------------|--|---------------|------------------------------|
| B' x H' | | | | |
| [mm] | - | [A] | [°] | [m ²] |
| 1300 x 1900 | HCV500/350 | 1,4 / 0,7 | 11 | 0,52 |
| 1300 x 2000 | KR10B-500 | 1,0 | 15 | 0,73 |
| 1300 x 2000 | KR10B-400 | 1,0 | 12 | 0,62 |
| 1300 x 2000 | HCV500/1000 | 1,4 / 0,7 | 31 | 1,12 |
| 1300 x 2000 | HCV500/800 | 1,4 / 0,7 | 24 | 1,00 |
| 1300 x 2000 | HCV500/600 | 1,4 / 0,7 | 18 | 0,84 |
| 1300 x 2000 | HCV500/350 | 1,4 / 0,7 | 10 | 0,56 |
| 1300 x 2100 | KR10B-500 | 1,0 | 14 | 0,77 |
| 1300 x 2100 | KR10B-400 | 1,0 | 12 | 0,66 |
| 1300 x 2100 | HCV500/1000 | 1,4 / 0,7 | 29 | 1,18 |
| 1300 x 2100 | HCV500/800 | 1,4 / 0,7 | 23 | 1,05 |
| 1300 x 2100 | HCV500/600 | 1,4 / 0,7 | 17 | 0,87 |
| 1300 x 2100 | HCV500/350 | 1,4 / 0,7 | 10 | 0,35 |
| 1300 x 2200 | KR10B-500 | 1,0 | 14 | 0,84 |
| 1300 x 2200 | KR10B-400 | 1,0 | 12 | 0,72 |
| 1300 x 2200 | HCV500/1000 | 1,4 / 0,7 | 28 | 1,24 |
| 1300 x 2200 | HCV500/800 | 1,4 / 0,7 | 22 | 1,11 |
| 1300 x 2200 | HCV500/600 | 1,4 / 0,7 | 16 | 0,92 |
| 1300 x 2200 | HCV500/350 | 1,4 / 0,7 | 9 | 0,36 |
| 1400 x 800 | KR10B-400 | 1,0 | 34 | 0,34 |
| 1400 x 800 | HCV500/1000 | 1,4 / 0,7 | 92 | 0,56 |
| 1400 x 800 | HCV500/800 | 1,4 / 0,7 | 70 | 0,52 |
| 1400 x 800 | HCV500/600 | 1,4 / 0,7 | 51 | 0,44 |
| 1400 x 800 | HCV500/350 | 1,4 / 0,7 | 29 | 0,30 |
| 1400 x 900 | KR10B-400 | 1,0 | 29 | 0,37 |
| 1400 x 900 | HCV500/1000 | 1,4 / 0,7 | 78 | 0,62 |
| 1400 x 900 | HCV500/800 | 1,4 / 0,7 | 60 | 0,56 |
| 1400 x 900 | HCV500/600 | 1,4 / 0,7 | 44 | 0,48 |
| 1400 x 900 | HCV500/350 | 1,4 / 0,7 | 25 | 0,33 |
| 1400 x 1000 | KR10B-400 | 1,0 | 26 | 0,39 |
| 1400 x 1000 | HCV500/1000 | 1,4 / 0,7 | 68 | 0,66 |
| 1400 x 1000 | HCV500/800 | 1,4 / 0,7 | 53 | 0,59 |
| 1400 x 1000 | HCV500/600 | 1,4 / 0,7 | 39 | 0,51 |
| 1400 x 1000 | HCV500/350 | 1,4 / 0,7 | 22 | 0,35 |
| 1400 x 1100 | KR10B-400 | 1,0 | 23 | 0,41 |
| 1400 x 1100 | HCV500/1000 | 1,4 / 0,7 | 60 | 0,71 |
| 1400 x 1100 | HCV500/800 | 1,4 / 0,7 | 47 | 0,64 |
| 1400 x 1100 | HCV500/600 | 1,4 / 0,7 | 35 | 0,54 |
| 1400 x 1100 | HCV500/350 | 1,4 / 0,7 | 20 | 0,37 |
| 1400 x 1200 | KR10B-400 | 1,0 | 21 | 0,44 |
| 1400 x 1200 | HCV500/1000 | 1,4 / 0,7 | 54 | 0,76 |
| 1400 x 1200 | HCV500/800 | 1,4 / 0,7 | 43 | 0,68 |
| 1400 x 1200 | HCV500/600 | 1,4 / 0,7 | 32 | 0,57 |
| 1400 x 1200 | HCV500/350 | 1,4 / 0,7 | 18 | 0,39 |

1.1.5.2. technical specification - top- and bottom-opening smoke exhaust windows opening outwards with chain actuators

| WINDOW SIZE** | ACTUATOR* | POWER CONSUMPTION FOR 24 V- / 48 V-*** | OPENING ANGLE | ACTIVE AERODYNAMIC AREA [Aa] | WINDOW SIZE** | ACTUATOR* | POWER CONSUMPTION FOR 24 V- / 48 V-*** | OPENING ANGLE | ACTIVE AERODYNAMIC AREA [Aa] |
|---------------|-------------|--|---------------|------------------------------|---------------|-------------|--|---------------|------------------------------|
| B' x H' | | | | | B' x H' | | | | |
| [mm] | - | [A] | [°] | [m ²] | [mm] | - | [A] | [°] | [m ²] |
| 1400 x 1300 | KR10B-400 | 1,0 | 19 | 0,47 | 1400 x 2000 | HCV500/800 | 1,4 / 0,7 | 24 | 1,06 |
| 1400 x 1300 | HCV500/1000 | 1,4 / 0,7 | 49 | 0,81 | 1400 x 2000 | HCV500/600 | 1,4 / 0,7 | 18 | 0,89 |
| 1400 x 1300 | HCV500/800 | 1,4 / 0,7 | 39 | 0,73 | 1400 x 2000 | HCV500/350 | 1,4 / 0,7 | 10 | 0,59 |
| 1400 x 1300 | HCV500/600 | 1,4 / 0,7 | 29 | 0,61 | 1400 x 2100 | KR10B-500 | 1,0 | 14 | 0,82 |
| 1400 x 1300 | HCV500/350 | 1,4 / 0,7 | 17 | 0,40 | 1400 x 2100 | KR10B-400 | 1,0 | 12 | 0,70 |
| 1400 x 1400 | KR10B-500 | 1,0 | 22 | 0,58 | 1400 x 2100 | HCV500/1000 | 1,4 / 0,7 | 29 | 1,27 |
| 1400 x 1400 | KR10B-400 | 1,0 | 18 | 0,48 | 1400 x 2100 | HCV500/800 | 1,4 / 0,7 | 23 | 1,12 |
| 1400 x 1400 | HCV500/1000 | 1,4 / 0,7 | 45 | 0,85 | 1400 x 2100 | HCV500/600 | 1,4 / 0,7 | 17 | 0,93 |
| 1400 x 1400 | HCV500/800 | 1,4 / 0,7 | 36 | 0,77 | 1400 x 2100 | HCV500/350 | 1,4 / 0,7 | 10 | 0,38 |
| 1400 x 1400 | HCV500/600 | 1,4 / 0,7 | 27 | 0,64 | 1400 x 2200 | KR10B-500 | 1,0 | 14 | 0,90 |
| 1400 x 1400 | HCV500/350 | 1,4 / 0,7 | 15 | 0,42 | 1400 x 2200 | KR10B-400 | 1,0 | 12 | 0,77 |
| 1400 x 1500 | KR10B-500 | 1,0 | 21 | 0,62 | 1400 x 2200 | HCV500/1000 | 1,4 / 0,7 | 28 | 1,33 |
| 1400 x 1500 | KR10B-400 | 1,0 | 17 | 0,51 | 1400 x 2200 | HCV500/800 | 1,4 / 0,7 | 22 | 1,19 |
| 1400 x 1500 | HCV500/1000 | 1,4 / 0,7 | 42 | 0,91 | 1400 x 2200 | HCV500/600 | 1,4 / 0,7 | 16 | 0,98 |
| 1400 x 1500 | HCV500/800 | 1,4 / 0,7 | 33 | 0,81 | 1400 x 2200 | HCV500/350 | 1,4 / 0,7 | 9 | 0,39 |
| 1400 x 1500 | HCV500/600 | 1,4 / 0,7 | 25 | 0,68 | 1500 x 800 | KR10B-400 | 1,0 | 34 | 0,37 |
| 1400 x 1500 | HCV500/350 | 1,4 / 0,7 | 14 | 0,44 | 1500 x 800 | HCV500/1000 | 1,4 / 0,7 | 92 | 0,60 |
| 1400 x 1600 | KR10B-500 | 1,0 | 19 | 0,65 | 1500 x 800 | HCV500/800 | 1,4 / 0,7 | 70 | 0,56 |
| 1400 x 1600 | KR10B-400 | 1,0 | 15 | 0,53 | 1500 x 800 | HCV500/600 | 1,4 / 0,7 | 51 | 0,48 |
| 1400 x 1600 | HCV500/1000 | 1,4 / 0,7 | 39 | 0,97 | 1500 x 800 | HCV500/350 | 1,4 / 0,7 | 29 | 0,33 |
| 1400 x 1600 | HCV500/800 | 1,4 / 0,7 | 31 | 0,86 | 1500 x 900 | KR10B-400 | 1,0 | 29 | 0,39 |
| 1400 x 1600 | HCV500/600 | 1,4 / 0,7 | 23 | 0,73 | 1500 x 900 | HCV500/1000 | 1,4 / 0,7 | 78 | 0,66 |
| 1400 x 1600 | HCV500/350 | 1,4 / 0,7 | 13 | 0,47 | 1500 x 900 | HCV500/800 | 1,4 / 0,7 | 60 | 0,60 |
| 1400 x 1700 | KR10B-500 | 1,0 | 18 | 0,68 | 1500 x 900 | HCV500/600 | 1,4 / 0,7 | 44 | 0,51 |
| 1400 x 1700 | KR10B-400 | 1,0 | 14 | 0,56 | 1500 x 900 | HCV500/350 | 1,4 / 0,7 | 25 | 0,35 |
| 1400 x 1700 | HCV500/1000 | 1,4 / 0,7 | 36 | 1,01 | 1500 x 1000 | KR10B-400 | 1,0 | 26 | 0,41 |
| 1400 x 1700 | HCV500/800 | 1,4 / 0,7 | 29 | 0,91 | 1500 x 1000 | HCV500/1000 | 1,4 / 0,7 | 68 | 0,72 |
| 1400 x 1700 | HCV500/600 | 1,4 / 0,7 | 22 | 0,77 | 1500 x 1000 | HCV500/800 | 1,4 / 0,7 | 53 | 0,64 |
| 1400 x 1700 | HCV500/350 | 1,4 / 0,7 | 12 | 0,49 | 1500 x 1000 | HCV500/600 | 1,4 / 0,7 | 39 | 0,55 |
| 1400 x 1800 | KR10B-500 | 1,0 | 17 | 0,71 | 1500 x 1000 | HCV500/350 | 1,4 / 0,7 | 22 | 0,37 |
| 1400 x 1800 | KR10B-400 | 1,0 | 14 | 0,59 | 1500 x 1100 | KR10B-400 | 1,0 | 23 | 0,44 |
| 1400 x 1800 | HCV500/1000 | 1,4 / 0,7 | 34 | 1,07 | 1500 x 1100 | HCV500/1000 | 1,4 / 0,7 | 60 | 0,77 |
| 1400 x 1800 | HCV500/800 | 1,4 / 0,7 | 27 | 0,96 | 1500 x 1100 | HCV500/800 | 1,4 / 0,7 | 47 | 0,69 |
| 1400 x 1800 | HCV500/600 | 1,4 / 0,7 | 20 | 0,82 | 1500 x 1100 | HCV500/600 | 1,4 / 0,7 | 35 | 0,58 |
| 1400 x 1800 | HCV500/350 | 1,4 / 0,7 | 12 | 0,52 | 1500 x 1100 | HCV500/350 | 1,4 / 0,7 | 20 | 0,40 |
| 1400 x 1900 | KR10B-500 | 1,0 | 16 | 0,74 | 1500 x 1200 | KR10B-400 | 1,0 | 21 | 0,47 |
| 1400 x 1900 | KR10B-400 | 1,0 | 13 | 0,62 | 1500 x 1200 | HCV500/1000 | 1,4 / 0,7 | 54 | 0,82 |
| 1400 x 1900 | HCV500/1000 | 1,4 / 0,7 | 32 | 1,14 | 1500 x 1200 | HCV500/800 | 1,4 / 0,7 | 43 | 0,74 |
| 1400 x 1900 | HCV500/800 | 1,4 / 0,7 | 26 | 1,01 | 1500 x 1200 | HCV500/600 | 1,4 / 0,7 | 32 | 0,62 |
| 1400 x 1900 | HCV500/600 | 1,4 / 0,7 | 19 | 0,86 | 1500 x 1200 | HCV500/350 | 1,4 / 0,7 | 18 | 0,41 |
| 1400 x 1900 | HCV500/350 | 1,4 / 0,7 | 11 | 0,56 | 1500 x 1300 | KR10B-400 | 1,0 | 19 | 0,50 |
| 1400 x 2000 | KR10B-500 | 1,0 | 15 | 0,78 | 1500 x 1300 | HCV500/1000 | 1,4 / 0,7 | 49 | 0,87 |
| 1400 x 2000 | KR10B-400 | 1,0 | 12 | 0,66 | 1500 x 1300 | HCV500/800 | 1,4 / 0,7 | 39 | 0,78 |
| 1400 x 2000 | HCV500/1000 | 1,4 / 0,7 | 31 | 1,20 | 1500 x 1300 | HCV500/600 | 1,4 / 0,7 | 29 | 0,65 |

1.1.5.2. technical specification - top- and bottom-opening smoke exhaust windows opening outwards with chain actuators

| WINDOW SIZE** | ACTUATOR* | POWER CONSUMPTION FOR 24 V- / 48 V-*** | OPENING ANGLE | ACTIVE AERODYNAMIC AREA [Aa] | WINDOW SIZE** | ACTUATOR* | POWER CONSUMPTION FOR 24 V- / 48 V-*** | OPENING ANGLE | ACTIVE AERODYNAMIC AREA [Aa] |
|---------------|-------------|--|---------------|------------------------------|---------------|-------------|--|---------------|------------------------------|
| B' x H' | | | | | B' x H' | | | | |
| [mm] | - | [A] | [°] | [m ²] | [mm] | - | [A] | [°] | [m ²] |
| 1500 x 1300 | HCV500/350 | 1,4 / 0,7 | 17 | 0,43 | 1500 x 2200 | KR10B-500 | 1,0 | 14 | 0,95 |
| 1500 x 1400 | KR10B-400 | 1,0 | 18 | 0,52 | 1500 x 2200 | KR10B-400 | 1,0 | 12 | 0,81 |
| 1500 x 1400 | HCV500/1000 | 1,4 / 0,7 | 45 | 0,92 | 1500 x 2200 | HCV500/1000 | 1,4 / 0,7 | 28 | 1,42 |
| 1500 x 1400 | HCV500/800 | 1,4 / 0,7 | 36 | 0,82 | 1500 x 2200 | HCV500/800 | 1,4 / 0,7 | 22 | 1,27 |
| 1500 x 1400 | HCV500/600 | 1,4 / 0,7 | 27 | 0,69 | 1500 x 2200 | HCV500/600 | 1,4 / 0,7 | 16 | 1,04 |
| 1500 x 1400 | HCV500/350 | 1,4 / 0,7 | 15 | 0,45 | 1500 x 2200 | HCV500/350 | 1,4 / 0,7 | 9 | 0,43 |
| 1500 x 1500 | KR10B-400 | 1,0 | 17 | 0,54 | 1600 x 800 | KR10B-500 | 2x 1,0 | 42 | 0,46 |
| 1500 x 1500 | HCV500/1000 | 1,4 / 0,7 | 42 | 0,98 | 1600 x 800 | KR10B-400 | 2x 1,0 | 34 | 0,39 |
| 1500 x 1500 | HCV500/800 | 1,4 / 0,7 | 33 | 0,87 | 1600 x 800 | HCV500/1000 | 1,4 / 0,7 | 92 | 0,64 |
| 1500 x 1500 | HCV500/600 | 1,4 / 0,7 | 25 | 0,73 | 1600 x 800 | HCV500/800 | 1,4 / 0,7 | 70 | 0,59 |
| 1500 x 1500 | HCV500/350 | 1,4 / 0,7 | 14 | 0,47 | 1600 x 800 | HCV500/600 | 1,4 / 0,7 | 51 | 0,51 |
| 1500 x 1600 | KR10B-400 | 1,0 | 15 | 0,56 | 1600 x 800 | HCV500/350 | 1,4 / 0,7 | 29 | 0,35 |
| 1500 x 1600 | HCV500/1000 | 1,4 / 0,7 | 39 | 1,03 | 1600 x 900 | KR10B-500 | 2x 1,0 | 37 | 0,49 |
| 1500 x 1600 | HCV500/800 | 1,4 / 0,7 | 31 | 0,92 | 1600 x 900 | KR10B-400 | 2x 1,0 | 29 | 0,42 |
| 1500 x 1600 | HCV500/600 | 1,4 / 0,7 | 23 | 0,77 | 1600 x 900 | HCV500/1000 | 1,4 / 0,7 | 78 | 0,71 |
| 1500 x 1600 | HCV500/350 | 1,4 / 0,7 | 13 | 0,49 | 1600 x 900 | HCV500/800 | 1,4 / 0,7 | 60 | 0,64 |
| 1500 x 1700 | KR10B-400 | 1,0 | 14 | 0,59 | 1600 x 900 | HCV500/600 | 1,4 / 0,7 | 44 | 0,55 |
| 1500 x 1700 | HCV500/1000 | 1,4 / 0,7 | 36 | 1,09 | 1600 x 900 | HCV500/350 | 1,4 / 0,7 | 25 | 0,37 |
| 1500 x 1700 | HCV500/800 | 1,4 / 0,7 | 29 | 0,97 | 1600 x 1000 | KR10B-500 | 2x 1,0 | 33 | 0,52 |
| 1500 x 1700 | HCV500/600 | 1,4 / 0,7 | 22 | 0,82 | 1600 x 1000 | KR10B-400 | 2x 1,0 | 26 | 0,44 |
| 1500 x 1700 | HCV500/350 | 1,4 / 0,7 | 12 | 0,52 | 1600 x 1000 | HCV500/1000 | 1,4 / 0,7 | 68 | 0,77 |
| 1500 x 1800 | KR10B-400 | 1,0 | 14 | 0,63 | 1600 x 1000 | HCV500/800 | 1,4 / 0,7 | 53 | 0,69 |
| 1500 x 1800 | HCV500/1000 | 1,4 / 0,7 | 34 | 1,15 | 1600 x 1000 | HCV500/600 | 1,4 / 0,7 | 39 | 0,59 |
| 1500 x 1800 | HCV500/800 | 1,4 / 0,7 | 27 | 1,02 | 1600 x 1000 | HCV500/350 | 1,4 / 0,7 | 22 | 0,40 |
| 1500 x 1800 | HCV500/600 | 1,4 / 0,7 | 20 | 0,87 | 1600 x 1100 | KR10B-500 | 2x 1,0 | 29 | 0,55 |
| 1500 x 1800 | HCV500/350 | 1,4 / 0,7 | 12 | 0,55 | 1600 x 1100 | KR10B-400 | 2x 1,0 | 23 | 0,47 |
| 1500 x 1900 | KR10B-500 | 1,0 | 16 | 0,79 | 1600 x 1100 | HCV500/1000 | 1,4 / 0,7 | 60 | 0,82 |
| 1500 x 1900 | KR10B-400 | 1,0 | 13 | 0,66 | 1600 x 1100 | HCV500/800 | 1,4 / 0,7 | 47 | 0,74 |
| 1500 x 1900 | HCV500/1000 | 1,4 / 0,7 | 32 | 1,21 | 1600 x 1100 | HCV500/600 | 1,4 / 0,7 | 35 | 0,62 |
| 1500 x 1900 | HCV500/800 | 1,4 / 0,7 | 26 | 1,08 | 1600 x 1100 | HCV500/350 | 1,4 / 0,7 | 20 | 0,43 |
| 1500 x 1900 | HCV500/600 | 1,4 / 0,7 | 19 | 0,91 | 1600 x 1200 | KR10B-500 | 2x 1,0 | 26 | 0,58 |
| 1500 x 1900 | HCV500/350 | 1,4 / 0,7 | 11 | 0,59 | 1600 x 1200 | KR10B-400 | 2x 1,0 | 21 | 0,50 |
| 1500 x 2000 | KR10B-500 | 1,0 | 15 | 0,83 | 1600 x 1200 | HCV500/1000 | 1,4 / 0,7 | 54 | 0,87 |
| 1500 x 2000 | KR10B-400 | 1,0 | 12 | 0,70 | 1600 x 1200 | HCV500/800 | 1,4 / 0,7 | 43 | 0,78 |
| 1500 x 2000 | HCV500/1000 | 1,4 / 0,7 | 31 | 1,29 | 1600 x 1200 | HCV500/600 | 1,4 / 0,7 | 32 | 0,65 |
| 1500 x 2000 | HCV500/800 | 1,4 / 0,7 | 24 | 1,14 | 1600 x 1200 | HCV500/350 | 1,4 / 0,7 | 18 | 0,44 |
| 1500 x 2000 | HCV500/600 | 1,4 / 0,7 | 18 | 0,95 | 1600 x 1300 | KR10B-500 | 2x 1,0 | 24 | 0,62 |
| 1500 x 2000 | HCV500/350 | 1,4 / 0,7 | 10 | 0,63 | 1600 x 1300 | KR10B-400 | 2x 1,0 | 19 | 0,53 |
| 1500 x 2100 | KR10B-500 | 1,0 | 14 | 0,87 | 1600 x 1300 | HCV500/1000 | 1,4 / 0,7 | 49 | 0,93 |
| 1500 x 2100 | KR10B-400 | 1,0 | 12 | 0,74 | 1600 x 1300 | HCV500/800 | 1,4 / 0,7 | 39 | 0,83 |
| 1500 x 2100 | HCV500/1000 | 1,4 / 0,7 | 29 | 1,35 | 1600 x 1300 | HCV500/600 | 1,4 / 0,7 | 29 | 0,69 |
| 1500 x 2100 | HCV500/800 | 1,4 / 0,7 | 23 | 1,20 | 1600 x 1300 | HCV500/350 | 1,4 / 0,7 | 17 | 0,45 |
| 1500 x 2100 | HCV500/600 | 1,4 / 0,7 | 17 | 0,99 | 1600 x 1400 | KR10B-500 | 2x 1,0 | 22 | 0,66 |
| 1500 x 2100 | HCV500/350 | 1,4 / 0,7 | 10 | 0,41 | 1600 x 1400 | KR10B-400 | 2x 1,0 | 18 | 0,55 |

1.1.5.2. technical specification - top- and bottom-opening smoke exhaust windows opening outwards with chain actuators

| WINDOW SIZE** | ACTUATOR* | POWER CONSUMPTION FOR 24 V- / 48 V-*** | OPENING ANGLE | ACTIVE AERODYNAMIC AREA [Aa] |
|---------------|-------------|--|---------------|------------------------------|
| B' x H' | | | | |
| [mm] | - | [A] | [°] | [m ²] |
| 1600 x 1400 | HCV500/1000 | 1,4 / 0,7 | 45 | 0,98 |
| 1600 x 1400 | HCV500/800 | 1,4 / 0,7 | 36 | 0,88 |
| 1600 x 1400 | HCV500/600 | 1,4 / 0,7 | 27 | 0,73 |
| 1600 x 1400 | HCV500/350 | 1,4 / 0,7 | 15 | 0,47 |
| 1600 x 1500 | KR10B-500 | 2x 1,0 | 21 | 0,70 |
| 1600 x 1500 | KR10B-400 | 2x 1,0 | 17 | 0,57 |
| 1600 x 1500 | HCV500/1000 | 1,4 / 0,7 | 42 | 1,04 |
| 1600 x 1500 | HCV500/800 | 1,4 / 0,7 | 33 | 0,92 |
| 1600 x 1500 | HCV500/600 | 1,4 / 0,7 | 25 | 0,77 |
| 1600 x 1500 | HCV500/350 | 1,4 / 0,7 | 14 | 0,49 |
| 1600 x 1600 | KR10B-500 | 2x 1,0 | 19 | 0,73 |
| 1600 x 1600 | KR10B-400 | 2x 1,0 | 15 | 0,60 |
| 1600 x 1600 | HCV500/1000 | 1,4 / 0,7 | 39 | 1,10 |
| 1600 x 1600 | HCV500/800 | 1,4 / 0,7 | 31 | 0,98 |
| 1600 x 1600 | HCV500/600 | 1,4 / 0,7 | 23 | 0,82 |
| 1600 x 1600 | HCV500/350 | 1,4 / 0,7 | 13 | 0,52 |
| 1600 x 1700 | KR10B-500 | 2x 1,0 | 18 | 0,77 |
| 1600 x 1700 | KR10B-400 | 2x 1,0 | 14 | 0,63 |
| 1600 x 1700 | HCV500/1000 | 1,4 / 0,7 | 36 | 1,16 |
| 1600 x 1700 | HCV500/800 | 1,4 / 0,7 | 29 | 1,04 |
| 1600 x 1700 | HCV500/600 | 1,4 / 0,7 | 22 | 0,87 |
| 1600 x 1700 | HCV500/350 | 1,4 / 0,7 | 12 | 0,55 |
| 1600 x 1800 | KR10B-500 | 2x 1,0 | 17 | 0,80 |
| 1600 x 1800 | KR10B-400 | 2x 1,0 | 14 | 0,66 |
| 1600 x 1800 | HCV500/1000 | 1,4 / 0,7 | 34 | 1,22 |
| 1600 x 1800 | HCV500/800 | 1,4 / 0,7 | 27 | 1,09 |
| 1600 x 1800 | HCV500/600 | 1,4 / 0,7 | 20 | 0,92 |
| 1600 x 1800 | HCV500/350 | 1,4 / 0,7 | 12 | 0,58 |
| 1600 x 1900 | KR10B-500 | 2x 1,0 | 16 | 0,83 |
| 1600 x 1900 | KR10B-400 | 2x 1,0 | 13 | 0,70 |
| 1600 x 1900 | HCV500/1000 | 1,4 / 0,7 | 32 | 1,29 |
| 1600 x 1900 | HCV500/800 | 1,4 / 0,7 | 26 | 1,14 |
| 1600 x 1900 | HCV500/600 | 1,4 / 0,7 | 19 | 0,97 |
| 1600 x 1900 | HCV500/350 | 1,4 / 0,7 | 11 | 0,62 |
| 1600 x 2000 | KR10B-500 | 2x 1,0 | 15 | 0,88 |
| 1600 x 2000 | KR10B-400 | 2x 1,0 | 12 | 0,74 |
| 1600 x 2000 | HCV500/1000 | 1,4 / 0,7 | 31 | 1,37 |
| 1600 x 2000 | HCV500/800 | 1,4 / 0,7 | 24 | 1,21 |
| 1600 x 2000 | HCV500/600 | 1,4 / 0,7 | 18 | 1,01 |
| 1600 x 2000 | HCV500/350 | 1,4 / 0,7 | 10 | 0,66 |
| 1600 x 2100 | KR10B-500 | 2x 1,0 | 14 | 0,92 |
| 1600 x 2100 | KR10B-400 | 2x 1,0 | 12 | 0,78 |
| 1600 x 2100 | HCV500/1000 | 1,4 / 0,7 | 29 | 1,44 |
| 1600 x 2100 | HCV500/800 | 1,4 / 0,7 | 23 | 1,27 |

| WINDOW SIZE** | ACTUATOR* | POWER CONSUMPTION FOR 24 V- / 48 V-*** | OPENING ANGLE | ACTIVE AERODYNAMIC AREA [Aa] |
|---------------|-------------|--|---------------|------------------------------|
| B' x H' | | | | |
| [mm] | - | [A] | [°] | [m ²] |
| 1600 x 2100 | HCV500/600 | 1,4 / 0,7 | 17 | 1,05 |
| 1600 x 2100 | HCV500/350 | 1,4 / 0,7 | 10 | 0,44 |
| 1600 x 2200 | KR10B-500 | 2x 1,0 | 14 | 1,00 |
| 1600 x 2200 | KR10B-400 | 2x 1,0 | 12 | 0,86 |
| 1600 x 2200 | HCV500/1000 | 1,4 / 0,7 | 28 | 1,51 |
| 1600 x 2200 | HCV500/800 | 1,4 / 0,7 | 22 | 1,34 |
| 1600 x 2200 | HCV500/600 | 1,4 / 0,7 | 16 | 1,10 |
| 1600 x 2200 | HCV500/350 | 1,4 / 0,7 | 9 | 0,46 |
| 1700 x 800 | KR10B-500 | 2x 1,0 | 42 | 0,49 |
| 1700 x 800 | KR10B-400 | 2x 1,0 | 34 | 0,42 |
| 1700 x 800 | HCV500/1000 | 1,4 / 0,7 | 92 | 0,69 |
| 1700 x 800 | HCV500/800 | 1,4 / 0,7 | 70 | 0,64 |
| 1700 x 800 | HCV500/600 | 1,4 / 0,7 | 51 | 0,54 |
| 1700 x 800 | HCV500/350 | 1,4 / 0,7 | 29 | 0,37 |
| 1700 x 900 | KR10B-500 | 2x 1,0 | 37 | 0,52 |
| 1700 x 900 | KR10B-400 | 2x 1,0 | 29 | 0,44 |
| 1700 x 900 | HCV500/1000 | 1,4 / 0,7 | 78 | 0,76 |
| 1700 x 900 | HCV500/800 | 1,4 / 0,7 | 60 | 0,69 |
| 1700 x 900 | HCV500/600 | 1,4 / 0,7 | 44 | 0,59 |
| 1700 x 900 | HCV500/350 | 1,4 / 0,7 | 25 | 0,40 |
| 1700 x 1000 | KR10B-500 | 2x 1,0 | 33 | 0,55 |
| 1700 x 1000 | KR10B-400 | 2x 1,0 | 26 | 0,47 |
| 1700 x 1000 | HCV500/1000 | 1,4 / 0,7 | 68 | 0,82 |
| 1700 x 1000 | HCV500/800 | 1,4 / 0,7 | 53 | 0,74 |
| 1700 x 1000 | HCV500/600 | 1,4 / 0,7 | 39 | 0,63 |
| 1700 x 1000 | HCV500/350 | 1,4 / 0,7 | 22 | 0,42 |
| 1700 x 1100 | KR10B-500 | 2x 1,0 | 29 | 0,58 |
| 1700 x 1100 | KR10B-400 | 2x 1,0 | 23 | 0,50 |
| 1700 x 1100 | HCV500/1000 | 1,4 / 0,7 | 60 | 0,87 |
| 1700 x 1100 | HCV500/800 | 1,4 / 0,7 | 47 | 0,78 |
| 1700 x 1100 | HCV500/600 | 1,4 / 0,7 | 35 | 0,66 |
| 1700 x 1100 | HCV500/350 | 1,4 / 0,7 | 20 | 0,45 |
| 1700 x 1200 | KR10B-500 | 2x 1,0 | 26 | 0,62 |
| 1700 x 1200 | KR10B-400 | 2x 1,0 | 21 | 0,53 |
| 1700 x 1200 | HCV500/1000 | 1,4 / 0,7 | 54 | 0,93 |
| 1700 x 1200 | HCV500/800 | 1,4 / 0,7 | 43 | 0,83 |
| 1700 x 1200 | HCV500/600 | 1,4 / 0,7 | 32 | 0,70 |
| 1700 x 1200 | HCV500/350 | 1,4 / 0,7 | 18 | 0,46 |
| 1700 x 1300 | KR10B-500 | 2x 1,0 | 24 | 0,66 |
| 1700 x 1300 | KR10B-400 | 2x 1,0 | 19 | 0,56 |
| 1700 x 1300 | HCV500/1000 | 1,4 / 0,7 | 49 | 0,99 |
| 1700 x 1300 | HCV500/800 | 1,4 / 0,7 | 39 | 0,89 |
| 1700 x 1300 | HCV500/600 | 1,4 / 0,7 | 29 | 0,74 |
| 1700 x 1300 | HCV500/350 | 1,4 / 0,7 | 17 | 0,48 |

1.1.5.2. technical specification - top- and bottom-opening smoke exhaust windows opening outwards with chain actuators

| WINDOW SIZE** | ACTUATOR* | POWER CONSUMPTION FOR 24 V- / 48 V-*** | OPENING ANGLE | ACTIVE AERODYNAMIC AREA [Aa] |
|---------------|-------------|--|---------------|------------------------------|
| B' x H' | | | | |
| [mm] | - | [A] | [°] | [m ²] |
| 1700 x 1400 | KR10B-500 | 2x 1,0 | 22 | 0,69 |
| 1700 x 1400 | KR10B-400 | 2x 1,0 | 18 | 0,58 |
| 1700 x 1400 | HCV500/1000 | 1,4 / 0,7 | 45 | 1,04 |
| 1700 x 1400 | HCV500/800 | 1,4 / 0,7 | 36 | 0,93 |
| 1700 x 1400 | HCV500/600 | 1,4 / 0,7 | 27 | 0,77 |
| 1700 x 1400 | HCV500/350 | 1,4 / 0,7 | 15 | 0,50 |
| 1700 x 1500 | KR10B-500 | 2x 1,0 | 21 | 0,74 |
| 1700 x 1500 | KR10B-400 | 2x 1,0 | 17 | 0,60 |
| 1700 x 1500 | HCV500/1000 | 1,4 / 0,7 | 42 | 1,11 |
| 1700 x 1500 | HCV500/800 | 1,4 / 0,7 | 33 | 0,98 |
| 1700 x 1500 | HCV500/600 | 1,4 / 0,7 | 25 | 0,82 |
| 1700 x 1500 | HCV500/350 | 1,4 / 0,7 | 14 | 0,52 |
| 1700 x 1600 | KR10B-500 | 2x 1,0 | 19 | 0,78 |
| 1700 x 1600 | KR10B-400 | 2x 1,0 | 15 | 0,63 |
| 1700 x 1600 | HCV500/1000 | 1,4 / 0,7 | 39 | 1,17 |
| 1700 x 1600 | HCV500/800 | 1,4 / 0,7 | 31 | 1,04 |
| 1700 x 1600 | HCV500/600 | 1,4 / 0,7 | 23 | 0,87 |
| 1700 x 1600 | HCV500/350 | 1,4 / 0,7 | 13 | 0,55 |
| 1700 x 1700 | KR10B-500 | 2x 1,0 | 18 | 0,81 |
| 1700 x 1700 | KR10B-400 | 2x 1,0 | 14 | 0,66 |
| 1700 x 1700 | HCV500/1000 | 1,4 / 0,7 | 36 | 1,23 |
| 1700 x 1700 | HCV500/800 | 1,4 / 0,7 | 29 | 1,09 |
| 1700 x 1700 | HCV500/600 | 1,4 / 0,7 | 22 | 0,92 |
| 1700 x 1700 | HCV500/350 | 1,4 / 0,7 | 12 | 0,58 |
| 1700 x 1800 | KR10B-500 | 2x 1,0 | 17 | 0,84 |
| 1700 x 1800 | KR10B-400 | 2x 1,0 | 14 | 0,69 |
| 1700 x 1800 | HCV500/1000 | 1,4 / 0,7 | 34 | 1,29 |
| 1700 x 1800 | HCV500/800 | 1,4 / 0,7 | 27 | 1,15 |
| 1700 x 1800 | HCV500/600 | 1,4 / 0,7 | 20 | 0,98 |
| 1700 x 1800 | HCV500/350 | 1,4 / 0,7 | 12 | 0,61 |
| 1700 x 1900 | KR10B-500 | 2x 1,0 | 16 | 0,88 |
| 1700 x 1900 | KR10B-400 | 2x 1,0 | 13 | 0,73 |
| 1700 x 1900 | HCV500/1000 | 1,4 / 0,7 | 32 | 1,37 |
| 1700 x 1900 | HCV500/800 | 1,4 / 0,7 | 26 | 1,21 |
| 1700 x 1900 | HCV500/600 | 1,4 / 0,7 | 19 | 1,02 |
| 1700 x 1900 | HCV500/350 | 1,4 / 0,7 | 11 | 0,65 |
| 1700 x 2000 | KR10B-500 | 2x 1,0 | 15 | 0,92 |
| 1700 x 2000 | KR10B-400 | 2x 1,0 | 12 | 0,78 |
| 1700 x 2000 | HCV500/1000 | 1,4 / 0,7 | 31 | 1,45 |
| 1700 x 2000 | HCV500/800 | 1,4 / 0,7 | 24 | 1,28 |
| 1700 x 2000 | HCV500/600 | 1,4 / 0,7 | 18 | 1,06 |
| 1700 x 2000 | HCV500/350 | 1,4 / 0,7 | 10 | 0,69 |
| 1800 x 800 | KR10B-600 | 2x 1,0 | 51 | 0,58 |
| 1800 x 800 | KR10B-500 | 2x 1,0 | 42 | 0,52 |

| WINDOW SIZE** | ACTUATOR* | POWER CONSUMPTION FOR 24 V- / 48 V-*** | OPENING ANGLE | ACTIVE AERODYNAMIC AREA [Aa] |
|---------------|-------------|--|---------------|------------------------------|
| B' x H' | | | | |
| [mm] | - | [A] | [°] | [m ²] |
| 1800 x 800 | KR10B-400 | 2x 1,0 | 34 | 0,44 |
| 1800 x 800 | HCV500/1000 | 1,4 / 0,7 | 92 | 0,73 |
| 1800 x 800 | HCV500/800 | 1,4 / 0,7 | 70 | 0,68 |
| 1800 x 800 | HCV500/600 | 2x 1,4 / 2x 0,7 | 51 | 0,58 |
| 1800 x 800 | HCV500/350 | 2x 1,4 / 2x 0,7 | 29 | 0,40 |
| 1800 x 900 | KR10B-600 | 2x 1,0 | 44 | 0,63 |
| 1800 x 900 | KR10B-500 | 2x 1,0 | 37 | 0,56 |
| 1800 x 900 | KR10B-400 | 2x 1,0 | 29 | 0,47 |
| 1800 x 900 | HCV500/1000 | 1,4 / 0,7 | 78 | 0,82 |
| 1800 x 900 | HCV500/800 | 1,4 / 0,7 | 60 | 0,73 |
| 1800 x 900 | HCV500/600 | 2x 1,4 / 2x 0,7 | 44 | 0,62 |
| 1800 x 900 | HCV500/350 | 2x 1,4 / 2x 0,7 | 25 | 0,42 |
| 1800 x 1000 | KR10B-600 | 2x 1,0 | 39 | 0,67 |
| 1800 x 1000 | KR10B-500 | 2x 1,0 | 33 | 0,58 |
| 1800 x 1000 | KR10B-400 | 2x 1,0 | 26 | 0,50 |
| 1800 x 1000 | HCV500/1000 | 1,4 / 0,7 | 68 | 0,87 |
| 1800 x 1000 | HCV500/800 | 1,4 / 0,7 | 53 | 0,78 |
| 1800 x 1000 | HCV500/600 | 2x 1,4 / 2x 0,7 | 39 | 0,66 |
| 1800 x 1000 | HCV500/350 | 2x 1,4 / 2x 0,7 | 22 | 0,44 |
| 1800 x 1100 | KR10B-600 | 2x 1,0 | 35 | 0,70 |
| 1800 x 1100 | KR10B-500 | 2x 1,0 | 29 | 0,62 |
| 1800 x 1100 | KR10B-400 | 2x 1,0 | 23 | 0,53 |
| 1800 x 1100 | HCV500/1000 | 1,4 / 0,7 | 60 | 0,93 |
| 1800 x 1100 | HCV500/800 | 1,4 / 0,7 | 47 | 0,83 |
| 1800 x 1100 | HCV500/600 | 2x 1,4 / 2x 0,7 | 35 | 0,70 |
| 1800 x 1100 | HCV500/350 | 2x 1,4 / 2x 0,7 | 20 | 0,48 |
| 1800 x 1200 | KR10B-600 | 2x 1,0 | 32 | 0,74 |
| 1800 x 1200 | KR10B-500 | 2x 1,0 | 26 | 0,65 |
| 1800 x 1200 | KR10B-400 | 2x 1,0 | 21 | 0,56 |
| 1800 x 1200 | HCV500/1000 | 1,4 / 0,7 | 54 | 0,99 |
| 1800 x 1200 | HCV500/800 | 1,4 / 0,7 | 43 | 0,89 |
| 1800 x 1200 | HCV500/600 | 2x 1,4 / 2x 0,7 | 32 | 0,74 |
| 1800 x 1200 | HCV500/350 | 2x 1,4 / 2x 0,7 | 18 | 0,49 |
| 1800 x 1300 | KR10B-600 | 2x 1,0 | 29 | 0,78 |
| 1800 x 1300 | KR10B-500 | 2x 1,0 | 24 | 0,69 |
| 1800 x 1300 | KR10B-400 | 2x 1,0 | 19 | 0,59 |
| 1800 x 1300 | HCV500/1000 | 1,4 / 0,7 | 49 | 1,04 |
| 1800 x 1300 | HCV500/800 | 1,4 / 0,7 | 39 | 0,94 |
| 1800 x 1300 | HCV500/600 | 2x 1,4 / 2x 0,7 | 29 | 0,78 |
| 1800 x 1300 | HCV500/350 | 2x 1,4 / 2x 0,7 | 17 | 0,50 |
| 1800 x 1400 | KR10B-600 | 2x 1,0 | 27 | 0,82 |
| 1800 x 1400 | KR10B-500 | 2x 1,0 | 22 | 0,73 |
| 1800 x 1400 | KR10B-400 | 2x 1,0 | 18 | 0,61 |
| 1800 x 1400 | HCV500/1000 | 1,4 / 0,7 | 45 | 1,11 |

1.1.5.2. technical specification - top- and bottom-opening smoke exhaust windows opening outwards with chain actuators

| WINDOW SIZE** | ACTUATOR* | POWER CONSUMPTION FOR 24 V- / 48 V-*** | OPENING ANGLE | ACTIVE AERODYNAMIC AREA [Aa] |
|---------------|-------------|--|---------------|------------------------------|
| B' x H' | | | | |
| [mm] | - | [A] | [°] | [m ²] |
| 1800 x 1400 | HCV500/800 | 1,4 / 0,7 | 36 | 0,98 |
| 1800 x 1400 | HCV500/600 | 2x 1,4 / 2x 0,7 | 27 | 0,82 |
| 1800 x 1400 | HCV500/350 | 2x 1,4 / 2x 0,7 | 15 | 0,52 |
| 1800 x 1500 | KR10B-600 | 2x 1,0 | 25 | 0,87 |
| 1800 x 1500 | KR10B-500 | 2x 1,0 | 21 | 0,78 |
| 1800 x 1500 | KR10B-400 | 2x 1,0 | 17 | 0,64 |
| 1800 x 1500 | HCV500/1000 | 1,4 / 0,7 | 42 | 1,17 |
| 1800 x 1500 | HCV500/800 | 1,4 / 0,7 | 33 | 1,04 |
| 1800 x 1500 | HCV500/600 | 2x 1,4 / 2x 0,7 | 25 | 0,87 |
| 1800 x 1500 | HCV500/350 | 2x 1,4 / 2x 0,7 | 14 | 0,55 |
| 1800 x 1600 | KR10B-600 | 2x 1,0 | 23 | 0,92 |
| 1800 x 1600 | KR10B-500 | 2x 1,0 | 19 | 0,82 |
| 1800 x 1600 | KR10B-400 | 2x 1,0 | 15 | 0,66 |
| 1800 x 1600 | HCV500/1000 | 1,4 / 0,7 | 39 | 1,24 |
| 1800 x 1600 | HCV500/800 | 1,4 / 0,7 | 31 | 1,09 |
| 1800 x 1600 | HCV500/600 | 2x 1,4 / 2x 0,7 | 23 | 0,91 |
| 1800 x 1600 | HCV500/350 | 2x 1,4 / 2x 0,7 | 13 | 0,57 |
| 1800 x 1700 | KR10B-600 | 2x 1,0 | 22 | 0,97 |
| 1800 x 1700 | KR10B-500 | 2x 1,0 | 18 | 0,85 |
| 1800 x 1700 | KR10B-400 | 2x 1,0 | 14 | 0,69 |
| 1800 x 1700 | HCV500/1000 | 1,4 / 0,7 | 36 | 1,30 |
| 1800 x 1700 | HCV500/800 | 1,4 / 0,7 | 29 | 1,15 |
| 1800 x 1700 | HCV500/600 | 2x 1,4 / 2x 0,7 | 22 | 0,97 |
| 1800 x 1700 | HCV500/350 | 2x 1,4 / 2x 0,7 | 12 | 0,61 |
| 1800 x 1800 | KR10B-600 | 2x 1,0 | 20 | 1,03 |
| 1800 x 1800 | KR10B-500 | 2x 1,0 | 17 | 0,89 |
| 1800 x 1800 | KR10B-400 | 2x 1,0 | 14 | 0,73 |
| 1800 x 1800 | HCV500/1000 | 1,4 / 0,7 | 34 | 1,37 |
| 1800 x 1800 | HCV500/800 | 1,4 / 0,7 | 27 | 1,21 |
| 1800 x 1800 | HCV500/600 | 2x 1,4 / 2x 0,7 | 20 | 1,03 |
| 1800 x 1800 | HCV500/350 | 2x 1,4 / 2x 0,7 | 12 | 0,64 |
| 1800 x 1900 | KR10B-600 | 2x 1,0 | 19 | 1,08 |
| 1800 x 1900 | KR10B-500 | 2x 1,0 | 16 | 0,93 |
| 1800 x 1900 | KR10B-400 | 2x 1,0 | 13 | 0,77 |
| 1800 x 1900 | HCV500/1000 | 1,4 / 0,7 | 32 | 1,45 |
| 1800 x 1900 | HCV500/800 | 1,4 / 0,7 | 26 | 1,28 |
| 1800 x 1900 | HCV500/600 | 2x 1,4 / 2x 0,7 | 19 | 1,07 |
| 1800 x 1900 | HCV500/350 | 2x 1,4 / 2x 0,7 | 11 | 0,68 |
| 1900 x 800 | KR10B-600 | 2x 1,0 | 51 | 0,62 |
| 1900 x 800 | KR10B-500 | 2x 1,0 | 42 | 0,56 |
| 1900 x 800 | KR10B-400 | 2x 1,0 | 34 | 0,47 |
| 1900 x 800 | HCV500/1000 | 1,4 / 0,7 | 92 | 0,78 |
| 1900 x 800 | HCV500/800 | 1,4 / 0,7 | 70 | 0,72 |
| 1900 x 800 | HCV500/600 | 2x 1,4 / 2x 0,7 | 51 | 0,61 |

| WINDOW SIZE** | ACTUATOR* | POWER CONSUMPTION FOR 24 V- / 48 V-*** | OPENING ANGLE | ACTIVE AERODYNAMIC AREA [Aa] |
|---------------|-------------|--|---------------|------------------------------|
| B' x H' | | | | |
| [mm] | - | [A] | [°] | [m ²] |
| 1900 x 800 | HCV500/350 | 2x 1,4 / 2x 0,7 | 29 | 0,42 |
| 1900 x 900 | KR10B-600 | 2x 1,0 | 44 | 0,66 |
| 1900 x 900 | KR10B-500 | 2x 1,0 | 37 | 0,59 |
| 1900 x 900 | KR10B-400 | 2x 1,0 | 29 | 0,50 |
| 1900 x 900 | HCV500/1000 | 1,4 / 0,7 | 78 | 0,86 |
| 1900 x 900 | HCV500/800 | 1,4 / 0,7 | 60 | 0,77 |
| 1900 x 900 | HCV500/600 | 2x 1,4 / 2x 0,7 | 44 | 0,66 |
| 1900 x 900 | HCV500/350 | 2x 1,4 / 2x 0,7 | 25 | 0,44 |
| 1900 x 1000 | KR10B-600 | 2x 1,0 | 39 | 0,71 |
| 1900 x 1000 | KR10B-500 | 2x 1,0 | 33 | 0,62 |
| 1900 x 1000 | KR10B-400 | 2x 1,0 | 26 | 0,52 |
| 1900 x 1000 | HCV500/1000 | 1,4 / 0,7 | 68 | 0,92 |
| 1900 x 1000 | HCV500/800 | 1,4 / 0,7 | 53 | 0,82 |
| 1900 x 1000 | HCV500/600 | 2x 1,4 / 2x 0,7 | 39 | 0,70 |
| 1900 x 1000 | HCV500/350 | 2x 1,4 / 2x 0,7 | 22 | 0,47 |
| 1900 x 1100 | KR10B-600 | 2x 1,0 | 35 | 0,74 |
| 1900 x 1100 | KR10B-500 | 2x 1,0 | 29 | 0,65 |
| 1900 x 1100 | KR10B-400 | 2x 1,0 | 23 | 0,56 |
| 1900 x 1100 | HCV500/1000 | 1,4 / 0,7 | 60 | 0,99 |
| 1900 x 1100 | HCV500/800 | 1,4 / 0,7 | 47 | 0,88 |
| 1900 x 1100 | HCV500/600 | 2x 1,4 / 2x 0,7 | 35 | 0,74 |
| 1900 x 1100 | HCV500/350 | 2x 1,4 / 2x 0,7 | 20 | 0,50 |
| 1900 x 1200 | KR10B-600 | 2x 1,0 | 32 | 0,78 |
| 1900 x 1200 | KR10B-500 | 2x 1,0 | 26 | 0,69 |
| 1900 x 1200 | KR10B-400 | 2x 1,0 | 21 | 0,59 |
| 1900 x 1200 | HCV500/1000 | 1,4 / 0,7 | 54 | 1,04 |
| 1900 x 1200 | HCV500/800 | 1,4 / 0,7 | 43 | 0,93 |
| 1900 x 1200 | HCV500/600 | 2x 1,4 / 2x 0,7 | 32 | 0,78 |
| 1900 x 1200 | HCV500/350 | 2x 1,4 / 2x 0,7 | 18 | 0,51 |
| 1900 x 1300 | KR10B-600 | 2x 1,0 | 29 | 0,83 |
| 1900 x 1300 | KR10B-500 | 2x 1,0 | 24 | 0,73 |
| 1900 x 1300 | KR10B-400 | 2x 1,0 | 19 | 0,62 |
| 1900 x 1300 | HCV500/1000 | 1,4 / 0,7 | 49 | 1,11 |
| 1900 x 1300 | HCV500/800 | 1,4 / 0,7 | 39 | 0,99 |
| 1900 x 1300 | HCV500/600 | 2x 1,4 / 2x 0,7 | 29 | 0,82 |
| 1900 x 1300 | HCV500/350 | 2x 1,4 / 2x 0,7 | 17 | 0,53 |
| 1900 x 1400 | KR10B-600 | 2x 1,0 | 27 | 0,87 |
| 1900 x 1400 | KR10B-500 | 2x 1,0 | 22 | 0,77 |
| 1900 x 1400 | KR10B-400 | 2x 1,0 | 18 | 0,64 |
| 1900 x 1400 | HCV500/1000 | 1,4 / 0,7 | 45 | 1,17 |
| 1900 x 1400 | HCV500/800 | 1,4 / 0,7 | 36 | 1,04 |
| 1900 x 1400 | HCV500/600 | 2x 1,4 / 2x 0,7 | 27 | 0,86 |
| 1900 x 1400 | HCV500/350 | 2x 1,4 / 2x 0,7 | 15 | 0,55 |
| 1900 x 1500 | KR10B-600 | 2x 1,0 | 25 | 0,91 |

1.1.5.2. technical specification - top- and bottom-opening smoke exhaust windows opening outwards with chain actuators

| WINDOW SIZE** | ACTUATOR* | POWER CONSUMPTION FOR 24 V- / 48 V-*** | OPENING ANGLE | ACTIVE AERODYNAMIC AREA [Aa] |
|---------------|-------------|--|---------------|------------------------------|
| B' x H' | | | | |
| [mm] | - | [A] | [°] | [m ²] |
| 1900 x 1500 | KR10B-500 | 2x 1,0 | 21 | 0,82 |
| 1900 x 1500 | KR10B-400 | 2x 1,0 | 17 | 0,66 |
| 1900 x 1500 | HCV500/1000 | 1,4 / 0,7 | 42 | 1,24 |
| 1900 x 1500 | HCV500/800 | 1,4 / 0,7 | 33 | 1,09 |
| 1900 x 1500 | HCV500/600 | 2x 1,4 / 2x 0,7 | 25 | 0,91 |
| 1900 x 1500 | HCV500/350 | 2x 1,4 / 2x 0,7 | 14 | 0,57 |
| 1900 x 1600 | KR10B-600 | 2x 1,0 | 23 | 0,97 |
| 1900 x 1600 | KR10B-500 | 2x 1,0 | 19 | 0,86 |
| 1900 x 1600 | KR10B-400 | 2x 1,0 | 15 | 0,69 |
| 1900 x 1600 | HCV500/1000 | 1,4 / 0,7 | 39 | 1,31 |
| 1900 x 1600 | HCV500/800 | 1,4 / 0,7 | 31 | 1,15 |
| 1900 x 1600 | HCV500/600 | 2x 1,4 / 2x 0,7 | 23 | 0,96 |
| 1900 x 1600 | HCV500/350 | 2x 1,4 / 2x 0,7 | 13 | 0,60 |
| 1900 x 1700 | KR10B-600 | 2x 1,0 | 22 | 1,02 |
| 1900 x 1700 | KR10B-500 | 2x 1,0 | 18 | 0,89 |
| 1900 x 1700 | KR10B-400 | 2x 1,0 | 14 | 0,73 |
| 1900 x 1700 | HCV500/1000 | 1,4 / 0,7 | 36 | 1,37 |
| 1900 x 1700 | HCV500/800 | 1,4 / 0,7 | 29 | 1,22 |
| 1900 x 1700 | HCV500/600 | 2x 1,4 / 2x 0,7 | 22 | 1,02 |
| 1900 x 1700 | HCV500/350 | 2x 1,4 / 2x 0,7 | 12 | 0,63 |
| 1900 x 1800 | KR10B-600 | 2x 1,0 | 20 | 1,09 |
| 1900 x 1800 | KR10B-500 | 2x 1,0 | 17 | 0,93 |
| 1900 x 1800 | KR10B-400 | 2x 1,0 | 14 | 0,76 |
| 1900 x 1800 | HCV500/1000 | 1,4 / 0,7 | 34 | 1,44 |
| 1900 x 1800 | HCV500/800 | 1,4 / 0,7 | 27 | 1,28 |
| 1900 x 1800 | HCV500/600 | 2x 1,4 / 2x 0,7 | 20 | 1,08 |
| 1900 x 1800 | HCV500/350 | 2x 1,4 / 2x 0,7 | 12 | 0,67 |
| 2000 x 800 | KR10B-600 | 2x 1,0 | 51 | 0,65 |
| 2000 x 800 | KR10B-500 | 2x 1,0 | 42 | 0,58 |
| 2000 x 800 | KR10B-400 | 2x 1,0 | 34 | 0,49 |
| 2000 x 800 | HCV500/800 | 2x 1,4 / 2x 0,7 | 70 | 0,75 |
| 2000 x 800 | HCV500/600 | 2x 1,4 / 2x 0,7 | 51 | 0,64 |
| 2000 x 800 | HCV500/350 | 2x 1,4 / 2x 0,7 | 29 | 0,44 |
| 2000 x 900 | KR10B-600 | 2x 1,0 | 44 | 0,70 |
| 2000 x 900 | KR10B-500 | 2x 1,0 | 37 | 0,62 |
| 2000 x 900 | KR10B-400 | 2x 1,0 | 29 | 0,52 |
| 2000 x 900 | HCV500/1000 | 1,4 / 0,7 | 78 | 0,91 |
| 2000 x 900 | HCV500/800 | 2x 1,4 / 2x 0,7 | 60 | 0,81 |
| 2000 x 900 | HCV500/600 | 2x 1,4 / 2x 0,7 | 44 | 0,69 |
| 2000 x 900 | HCV500/350 | 2x 1,4 / 2x 0,7 | 25 | 0,46 |
| 2000 x 1000 | KR10B-600 | 2x 1,0 | 39 | 0,75 |
| 2000 x 1000 | KR10B-500 | 2x 1,0 | 33 | 0,65 |
| 2000 x 1000 | KR10B-400 | 2x 1,0 | 26 | 0,55 |
| 2000 x 1000 | HCV500/1000 | 1,4 / 0,7 | 68 | 0,98 |

| WINDOW SIZE** | ACTUATOR* | POWER CONSUMPTION FOR 24 V- / 48 V-*** | OPENING ANGLE | ACTIVE AERODYNAMIC AREA [Aa] |
|---------------|-------------|--|---------------|------------------------------|
| B' x H' | | | | |
| [mm] | - | [A] | [°] | [m ²] |
| 2000 x 1000 | HCV500/800 | 2x 1,4 / 2x 0,7 | 53 | 0,87 |
| 2000 x 1000 | HCV500/600 | 2x 1,4 / 2x 0,7 | 39 | 0,74 |
| 2000 x 1000 | HCV500/350 | 2x 1,4 / 2x 0,7 | 22 | 0,49 |
| 2000 x 1100 | KR10B-600 | 2x 1,0 | 35 | 0,78 |
| 2000 x 1100 | KR10B-500 | 2x 1,0 | 29 | 0,69 |
| 2000 x 1100 | KR10B-400 | 2x 1,0 | 23 | 0,58 |
| 2000 x 1100 | HCV500/1000 | 1,4 / 0,7 | 60 | 1,04 |
| 2000 x 1100 | HCV500/800 | 2x 1,4 / 2x 0,7 | 47 | 0,92 |
| 2000 x 1100 | HCV500/600 | 2x 1,4 / 2x 0,7 | 35 | 0,77 |
| 2000 x 1100 | HCV500/350 | 2x 1,4 / 2x 0,7 | 20 | 0,53 |
| 2000 x 1200 | KR10B-600 | 2x 1,0 | 32 | 0,82 |
| 2000 x 1200 | KR10B-500 | 2x 1,0 | 26 | 0,72 |
| 2000 x 1200 | KR10B-400 | 2x 1,0 | 21 | 0,62 |
| 2000 x 1200 | HCV500/1000 | 1,4 / 0,7 | 54 | 1,10 |
| 2000 x 1200 | HCV500/800 | 2x 1,4 / 2x 0,7 | 43 | 0,98 |
| 2000 x 1200 | HCV500/600 | 2x 1,4 / 2x 0,7 | 32 | 0,82 |
| 2000 x 1200 | HCV500/350 | 2x 1,4 / 2x 0,7 | 18 | 0,54 |
| 2000 x 1300 | KR10B-600 | 2x 1,0 | 29 | 0,87 |
| 2000 x 1300 | KR10B-500 | 2x 1,0 | 24 | 0,76 |
| 2000 x 1300 | KR10B-400 | 2x 1,0 | 19 | 0,65 |
| 2000 x 1300 | HCV500/1000 | 1,4 / 0,7 | 49 | 1,17 |
| 2000 x 1300 | HCV500/800 | 2x 1,4 / 2x 0,7 | 39 | 1,04 |
| 2000 x 1300 | HCV500/600 | 2x 1,4 / 2x 0,7 | 29 | 0,86 |
| 2000 x 1300 | HCV500/350 | 2x 1,4 / 2x 0,7 | 17 | 0,56 |
| 2000 x 1400 | KR10B-600 | 2x 1,0 | 27 | 0,91 |
| 2000 x 1400 | KR10B-500 | 2x 1,0 | 22 | 0,81 |
| 2000 x 1400 | KR10B-400 | 2x 1,0 | 18 | 0,67 |
| 2000 x 1400 | HCV500/1000 | 1,4 / 0,7 | 45 | 1,23 |
| 2000 x 1400 | HCV500/800 | 2x 1,4 / 2x 0,7 | 36 | 1,09 |
| 2000 x 1400 | HCV500/600 | 2x 1,4 / 2x 0,7 | 27 | 0,90 |
| 2000 x 1400 | HCV500/350 | 2x 1,4 / 2x 0,7 | 15 | 0,57 |
| 2000 x 1500 | KR10B-600 | 2x 1,0 | 25 | 0,96 |
| 2000 x 1500 | KR10B-500 | 2x 1,0 | 21 | 0,86 |
| 2000 x 1500 | KR10B-400 | 2x 1,0 | 17 | 0,70 |
| 2000 x 1500 | HCV500/1000 | 1,4 / 0,7 | 42 | 1,30 |
| 2000 x 1500 | HCV500/800 | 2x 1,4 / 2x 0,7 | 33 | 1,15 |
| 2000 x 1500 | HCV500/600 | 2x 1,4 / 2x 0,7 | 25 | 0,95 |
| 2000 x 1500 | HCV500/350 | 2x 1,4 / 2x 0,7 | 14 | 0,60 |
| 2000 x 1600 | KR10B-600 | 2x 1,0 | 23 | 1,01 |
| 2000 x 1600 | KR10B-500 | 2x 1,0 | 19 | 0,90 |
| 2000 x 1600 | KR10B-400 | 2x 1,0 | 15 | 0,72 |
| 2000 x 1600 | HCV500/1000 | 1,4 / 0,7 | 39 | 1,37 |
| 2000 x 1600 | HCV500/800 | 2x 1,4 / 2x 0,7 | 31 | 1,21 |
| 2000 x 1600 | HCV500/600 | 2x 1,4 / 2x 0,7 | 23 | 1,01 |

1.1.5.2. technical specification - top- and bottom-opening smoke exhaust windows opening outwards with chain actuators

| WINDOW SIZE** | ACTUATOR* | POWER CONSUMPTION FOR 24 V- / 48 V-*** | OPENING ANGLE | ACTIVE AERODYNAMIC AREA [Aa] |
|---------------|-------------|--|---------------|------------------------------|
| B' x H' | | | | |
| [mm] | - | [A] | [°] | [m ²] |
| 2000 x 1600 | HCV500/350 | 2x 1,4 / 2x 0,7 | 13 | 0,63 |
| 2000 x 1700 | KR10B-600 | 2x 1,0 | 22 | 1,07 |
| 2000 x 1700 | KR10B-500 | 2x 1,0 | 18 | 0,93 |
| 2000 x 1700 | KR10B-400 | 2x 1,0 | 14 | 0,76 |
| 2000 x 1700 | HCV500/1000 | 1,4 / 0,7 | 36 | 1,44 |
| 2000 x 1700 | HCV500/800 | 2x 1,4 / 2x 0,7 | 29 | 1,28 |
| 2000 x 1700 | HCV500/600 | 2x 1,4 / 2x 0,7 | 22 | 1,07 |
| 2000 x 1700 | HCV500/350 | 2x 1,4 / 2x 0,7 | 12 | 0,66 |
| 2100 x 800 | KR10B-500 | 2x 1,0 | 42 | 0,61 |
| 2100 x 800 | KR10B-400 | 2x 1,0 | 34 | 0,52 |
| 2100 x 800 | HCV500/800 | 2x 1,4 / 2x 0,7 | 70 | 0,80 |
| 2100 x 800 | HCV500/600 | 2x 1,4 / 2x 0,7 | 51 | 0,68 |
| 2100 x 800 | HCV500/350 | 2x 1,4 / 2x 0,7 | 29 | 0,46 |
| 2100 x 900 | KR10B-600 | 2x 1,0 | 44 | 0,73 |
| 2100 x 900 | KR10B-500 | 2x 1,0 | 37 | 0,65 |
| 2100 x 900 | KR10B-400 | 2x 1,0 | 29 | 0,55 |
| 2100 x 900 | HCV500/800 | 2x 1,4 / 2x 0,7 | 60 | 0,86 |
| 2100 x 900 | HCV500/600 | 2x 1,4 / 2x 0,7 | 44 | 0,73 |
| 2100 x 900 | HCV500/350 | 2x 1,4 / 2x 0,7 | 25 | 0,49 |
| 2100 x 1000 | KR10B-600 | 2x 1,0 | 39 | 0,78 |
| 2100 x 1000 | KR10B-500 | 2x 1,0 | 33 | 0,68 |
| 2100 x 1000 | KR10B-400 | 2x 1,0 | 26 | 0,58 |
| 2100 x 1000 | HCV500/1000 | 1,4 / 0,7 | 68 | 1,02 |
| 2100 x 1000 | HCV500/800 | 2x 1,4 / 2x 0,7 | 53 | 0,91 |
| 2100 x 1000 | HCV500/600 | 2x 1,4 / 2x 0,7 | 39 | 0,78 |
| 2100 x 1000 | HCV500/350 | 2x 1,4 / 2x 0,7 | 22 | 0,52 |
| 2100 x 1100 | KR10B-600 | 2x 1,0 | 35 | 0,82 |
| 2100 x 1100 | KR10B-500 | 2x 1,0 | 29 | 0,72 |
| 2100 x 1100 | KR10B-400 | 2x 1,0 | 23 | 0,61 |
| 2100 x 1100 | HCV500/1000 | 1,4 / 0,7 | 60 | 1,09 |
| 2100 x 1100 | HCV500/800 | 2x 1,4 / 2x 0,7 | 47 | 0,97 |
| 2100 x 1100 | HCV500/600 | 2x 1,4 / 2x 0,7 | 35 | 0,81 |
| 2100 x 1100 | HCV500/350 | 2x 1,4 / 2x 0,7 | 20 | 0,55 |
| 2100 x 1200 | KR10B-600 | 2x 1,0 | 32 | 0,86 |
| 2100 x 1200 | KR10B-500 | 2x 1,0 | 26 | 0,76 |
| 2100 x 1200 | KR10B-400 | 2x 1,0 | 21 | 0,65 |
| 2100 x 1200 | HCV500/1000 | 1,4 / 0,7 | 54 | 1,16 |
| 2100 x 1200 | HCV500/800 | 2x 1,4 / 2x 0,7 | 43 | 1,03 |
| 2100 x 1200 | HCV500/600 | 2x 1,4 / 2x 0,7 | 32 | 0,86 |
| 2100 x 1200 | HCV500/350 | 2x 1,4 / 2x 0,7 | 18 | 0,56 |
| 2100 x 1300 | KR10B-600 | 2x 1,0 | 29 | 0,91 |
| 2100 x 1300 | KR10B-500 | 2x 1,0 | 24 | 0,80 |
| 2100 x 1300 | KR10B-400 | 2x 1,0 | 19 | 0,68 |
| 2100 x 1300 | HCV500/1000 | 1,4 / 0,7 | 49 | 1,22 |

| WINDOW SIZE** | ACTUATOR* | POWER CONSUMPTION FOR 24 V- / 48 V-*** | OPENING ANGLE | ACTIVE AERODYNAMIC AREA [Aa] |
|---------------|-------------|--|---------------|------------------------------|
| B' x H' | | | | |
| [mm] | - | [A] | [°] | [m ²] |
| 2100 x 1300 | HCV500/800 | 2x 1,4 / 2x 0,7 | 39 | 1,09 |
| 2100 x 1300 | HCV500/600 | 2x 1,4 / 2x 0,7 | 29 | 0,90 |
| 2100 x 1300 | HCV500/350 | 2x 1,4 / 2x 0,7 | 17 | 0,58 |
| 2100 x 1400 | KR10B-600 | 2x 1,0 | 27 | 0,95 |
| 2100 x 1400 | KR10B-500 | 2x 1,0 | 22 | 0,84 |
| 2100 x 1400 | KR10B-400 | 2x 1,0 | 18 | 0,70 |
| 2100 x 1400 | HCV500/1000 | 1,4 / 0,7 | 45 | 1,29 |
| 2100 x 1400 | HCV500/800 | 2x 1,4 / 2x 0,7 | 36 | 1,14 |
| 2100 x 1400 | HCV500/600 | 2x 1,4 / 2x 0,7 | 27 | 0,95 |
| 2100 x 1400 | HCV500/350 | 2x 1,4 / 2x 0,7 | 15 | 0,60 |
| 2100 x 1500 | KR10B-600 | 2x 1,0 | 25 | 1,01 |
| 2100 x 1500 | KR10B-500 | 2x 1,0 | 21 | 0,90 |
| 2100 x 1500 | KR10B-400 | 2x 1,0 | 17 | 0,73 |
| 2100 x 1500 | HCV500/1000 | 1,4 / 0,7 | 42 | 1,37 |
| 2100 x 1500 | HCV500/800 | 2x 1,4 / 2x 0,7 | 33 | 1,20 |
| 2100 x 1500 | HCV500/600 | 2x 1,4 / 2x 0,7 | 25 | 1,00 |
| 2100 x 1500 | HCV500/350 | 2x 1,4 / 2x 0,7 | 14 | 0,62 |
| 2100 x 1600 | KR10B-600 | 2x 1,0 | 23 | 1,06 |
| 2100 x 1600 | KR10B-500 | 2x 1,0 | 19 | 0,94 |
| 2100 x 1600 | KR10B-400 | 2x 1,0 | 15 | 0,76 |
| 2100 x 1600 | HCV500/1000 | 1,4 / 0,7 | 39 | 1,44 |
| 2100 x 1600 | HCV500/800 | 2x 1,4 / 2x 0,7 | 31 | 1,27 |
| 2100 x 1600 | HCV500/600 | 2x 1,4 / 2x 0,7 | 23 | 1,06 |
| 2100 x 1600 | HCV500/350 | 2x 1,4 / 2x 0,7 | 13 | 0,65 |
| 2200 x 800 | KR10B-500 | 2x 1,0 | 42 | 0,65 |
| 2200 x 800 | KR10B-400 | 2x 1,0 | 34 | 0,55 |
| 2200 x 800 | HCV500/1000 | 2x 1,4 / 2x 0,7 | 92 | 0,91 |
| 2200 x 800 | HCV500/800 | 2x 1,4 / 2x 0,7 | 70 | 0,84 |
| 2200 x 800 | HCV500/600 | 2x 1,4 / 2x 0,7 | 51 | 0,71 |
| 2200 x 800 | HCV500/350 | 2x 1,4 / 2x 0,7 | 29 | 0,48 |
| 2200 x 900 | KR10B-500 | 2x 1,0 | 37 | 0,68 |
| 2200 x 900 | KR10B-400 | 2x 1,0 | 29 | 0,57 |
| 2200 x 900 | HCV500/1000 | 2x 1,4 / 2x 0,7 | 78 | 1,00 |
| 2200 x 900 | HCV500/800 | 2x 1,4 / 2x 0,7 | 60 | 0,90 |
| 2200 x 900 | HCV500/600 | 2x 1,4 / 2x 0,7 | 44 | 0,76 |
| 2200 x 900 | HCV500/350 | 2x 1,4 / 2x 0,7 | 25 | 0,51 |
| 2200 x 1000 | KR10B-600 | 2x 1,0 | 39 | 0,82 |
| 2200 x 1000 | KR10B-500 | 2x 1,0 | 33 | 0,72 |
| 2200 x 1000 | KR10B-400 | 2x 1,0 | 26 | 0,60 |
| 2200 x 1000 | HCV500/1000 | 2x 1,4 / 2x 0,7 | 68 | 1,08 |
| 2200 x 1000 | HCV500/800 | 2x 1,4 / 2x 0,7 | 53 | 0,96 |
| 2200 x 1000 | HCV500/600 | 2x 1,4 / 2x 0,7 | 39 | 0,81 |
| 2200 x 1000 | HCV500/350 | 2x 1,4 / 2x 0,7 | 22 | 0,54 |
| 2200 x 1100 | KR10B-600 | 2x 1,0 | 35 | 0,86 |

1.1.5.2. technical specification - top- and bottom-opening smoke exhaust windows opening outwards with chain actuators

| WINDOW SIZE** | ACTUATOR* | POWER CONSUMPTION FOR 24 V- / 48 V-*** | OPENING ANGLE | ACTIVE AERODYNAMIC AREA [Aa] |
|---------------|-------------|--|---------------|------------------------------|
| B' x H' | | | | |
| [mm] | - | [A] | [°] | [m ²] |
| 2200 x 1100 | KR10B-500 | 2x 1,0 | 29 | 0,75 |
| 2200 x 1100 | KR10B-400 | 2x 1,0 | 23 | 0,64 |
| 2200 x 1100 | HCV500/1000 | 2x 1,4 / 2x 0,7 | 60 | 1,15 |
| 2200 x 1100 | HCV500/800 | 2x 1,4 / 2x 0,7 | 47 | 1,02 |
| 2200 x 1100 | HCV500/600 | 2x 1,4 / 2x 0,7 | 35 | 0,85 |
| 2200 x 1100 | HCV500/350 | 2x 1,4 / 2x 0,7 | 20 | 0,58 |
| 2200 x 1200 | KR10B-600 | 2x 1,0 | 32 | 0,90 |
| 2200 x 1200 | KR10B-500 | 2x 1,0 | 26 | 0,79 |
| 2200 x 1200 | KR10B-400 | 2x 1,0 | 21 | 0,68 |
| 2200 x 1200 | HCV500/1000 | 2x 1,4 / 2x 0,7 | 54 | 1,21 |
| 2200 x 1200 | HCV500/800 | 2x 1,4 / 2x 0,7 | 43 | 1,08 |
| 2200 x 1200 | HCV500/600 | 2x 1,4 / 2x 0,7 | 32 | 0,89 |
| 2200 x 1200 | HCV500/350 | 2x 1,4 / 2x 0,7 | 18 | 0,59 |
| 2200 x 1300 | KR10B-600 | 2x 1,0 | 29 | 0,95 |
| 2200 x 1300 | KR10B-500 | 2x 1,0 | 24 | 0,83 |
| 2200 x 1300 | KR10B-400 | 2x 1,0 | 19 | 0,71 |
| 2200 x 1300 | HCV500/1000 | 2x 1,4 / 2x 0,7 | 49 | 1,28 |
| 2200 x 1300 | HCV500/800 | 2x 1,4 / 2x 0,7 | 39 | 1,14 |
| 2200 x 1300 | HCV500/600 | 2x 1,4 / 2x 0,7 | 29 | 0,94 |
| 2200 x 1300 | HCV500/350 | 2x 1,4 / 2x 0,7 | 17 | 0,60 |
| 2200 x 1400 | KR10B-600 | 2x 1,0 | 27 | 1,00 |
| 2200 x 1400 | KR10B-500 | 2x 1,0 | 22 | 0,88 |
| 2200 x 1400 | KR10B-400 | 2x 1,0 | 18 | 0,73 |
| 2200 x 1400 | HCV500/1000 | 2x 1,4 / 2x 0,7 | 45 | 1,36 |
| 2200 x 1400 | HCV500/800 | 2x 1,4 / 2x 0,7 | 36 | 1,20 |
| 2200 x 1400 | HCV500/600 | 2x 1,4 / 2x 0,7 | 27 | 0,99 |
| 2200 x 1400 | HCV500/350 | 2x 1,4 / 2x 0,7 | 15 | 0,63 |
| 2200 x 1500 | KR10B-600 | 2x 1,0 | 25 | 1,05 |
| 2200 x 1500 | KR10B-500 | 2x 1,0 | 21 | 0,94 |
| 2200 x 1500 | KR10B-400 | 2x 1,0 | 17 | 0,76 |
| 2200 x 1500 | HCV500/1000 | 2x 1,4 / 2x 0,7 | 42 | 1,43 |
| 2200 x 1500 | HCV500/800 | 2x 1,4 / 2x 0,7 | 33 | 1,26 |
| 2200 x 1500 | HCV500/600 | 2x 1,4 / 2x 0,7 | 25 | 1,04 |
| 2200 x 1500 | HCV500/350 | 2x 1,4 / 2x 0,7 | 14 | 0,65 |
| 2200 x 1600 | KR10B-600 | 2x 1,0 | 23 | 1,10 |
| 2200 x 1600 | KR10B-500 | 2x 1,0 | 19 | 0,98 |
| 2200 x 1600 | KR10B-400 | 2x 1,0 | 15 | 0,78 |
| 2200 x 1600 | HCV500/1000 | 2x 1,4 / 2x 0,7 | 39 | 1,51 |
| 2200 x 1600 | HCV500/800 | 2x 1,4 / 2x 0,7 | 31 | 1,32 |
| 2200 x 1600 | HCV500/600 | 2x 1,4 / 2x 0,7 | 23 | 1,10 |
| 2200 x 1600 | HCV500/350 | 2x 1,4 / 2x 0,7 | 13 | 0,68 |
| 2300 x 800 | KR10B-500 | 2x 1,0 | 42 | 0,67 |
| 2300 x 800 | KR10B-400 | 2x 1,0 | 34 | 0,57 |
| 2300 x 800 | HCV500/1000 | 2x 1,4 / 2x 0,7 | 92 | 0,95 |

| WINDOW SIZE** | ACTUATOR* | POWER CONSUMPTION FOR 24 V- / 48 V-*** | OPENING ANGLE | ACTIVE AERODYNAMIC AREA [Aa] |
|---------------|-------------|--|---------------|------------------------------|
| B' x H' | | | | |
| [mm] | - | [A] | [°] | [m ²] |
| 2300 x 800 | HCV500/800 | 2x 1,4 / 2x 0,7 | 70 | 0,87 |
| 2300 x 800 | HCV500/600 | 2x 1,4 / 2x 0,7 | 51 | 0,74 |
| 2300 x 800 | HCV500/350 | 2x 1,4 / 2x 0,7 | 29 | 0,50 |
| 2300 x 900 | KR10B-500 | 2x 1,0 | 37 | 0,71 |
| 2300 x 900 | KR10B-400 | 2x 1,0 | 29 | 0,60 |
| 2300 x 900 | HCV500/1000 | 2x 1,4 / 2x 0,7 | 78 | 1,05 |
| 2300 x 900 | HCV500/800 | 2x 1,4 / 2x 0,7 | 60 | 0,94 |
| 2300 x 900 | HCV500/600 | 2x 1,4 / 2x 0,7 | 44 | 0,80 |
| 2300 x 900 | HCV500/350 | 2x 1,4 / 2x 0,7 | 25 | 0,53 |
| 2300 x 1000 | KR10B-500 | 2x 1,0 | 33 | 0,75 |
| 2300 x 1000 | KR10B-400 | 2x 1,0 | 26 | 0,63 |
| 2300 x 1000 | HCV500/1000 | 2x 1,4 / 2x 0,7 | 68 | 1,13 |
| 2300 x 1000 | HCV500/800 | 2x 1,4 / 2x 0,7 | 53 | 1,00 |
| 2300 x 1000 | HCV500/600 | 2x 1,4 / 2x 0,7 | 39 | 0,85 |
| 2300 x 1000 | HCV500/350 | 2x 1,4 / 2x 0,7 | 22 | 0,57 |
| 2300 x 1100 | KR10B-600 | 2x 1,0 | 35 | 0,89 |
| 2300 x 1100 | KR10B-500 | 2x 1,0 | 29 | 0,78 |
| 2300 x 1100 | KR10B-400 | 2x 1,0 | 23 | 0,67 |
| 2300 x 1100 | HCV500/1000 | 2x 1,4 / 2x 0,7 | 60 | 1,20 |
| 2300 x 1100 | HCV500/800 | 2x 1,4 / 2x 0,7 | 47 | 1,06 |
| 2300 x 1100 | HCV500/600 | 2x 1,4 / 2x 0,7 | 35 | 0,89 |
| 2300 x 1100 | HCV500/350 | 2x 1,4 / 2x 0,7 | 20 | 0,60 |
| 2300 x 1200 | KR10B-600 | 2x 1,0 | 32 | 0,94 |
| 2300 x 1200 | KR10B-500 | 2x 1,0 | 26 | 0,83 |
| 2300 x 1200 | KR10B-400 | 2x 1,0 | 21 | 0,71 |
| 2300 x 1200 | HCV500/1000 | 2x 1,4 / 2x 0,7 | 54 | 1,27 |
| 2300 x 1200 | HCV500/800 | 2x 1,4 / 2x 0,7 | 43 | 1,13 |
| 2300 x 1200 | HCV500/600 | 2x 1,4 / 2x 0,7 | 32 | 0,93 |
| 2300 x 1200 | HCV500/350 | 2x 1,4 / 2x 0,7 | 18 | 0,61 |
| 2300 x 1300 | KR10B-600 | 2x 1,0 | 29 | 0,99 |
| 2300 x 1300 | KR10B-500 | 2x 1,0 | 24 | 0,87 |
| 2300 x 1300 | KR10B-400 | 2x 1,0 | 19 | 0,74 |
| 2300 x 1300 | HCV500/1000 | 2x 1,4 / 2x 0,7 | 49 | 1,34 |
| 2300 x 1300 | HCV500/800 | 2x 1,4 / 2x 0,7 | 39 | 1,20 |
| 2300 x 1300 | HCV500/600 | 2x 1,4 / 2x 0,7 | 29 | 0,98 |
| 2300 x 1300 | HCV500/350 | 2x 1,4 / 2x 0,7 | 17 | 0,63 |
| 2300 x 1400 | KR10B-600 | 2x 1,0 | 27 | 1,04 |
| 2300 x 1400 | KR10B-500 | 2x 1,0 | 22 | 0,92 |
| 2300 x 1400 | KR10B-400 | 2x 1,0 | 18 | 0,76 |
| 2300 x 1400 | HCV500/1000 | 2x 1,4 / 2x 0,7 | 45 | 1,42 |
| 2300 x 1400 | HCV500/800 | 2x 1,4 / 2x 0,7 | 36 | 1,25 |
| 2300 x 1400 | HCV500/600 | 2x 1,4 / 2x 0,7 | 27 | 1,03 |
| 2300 x 1400 | HCV500/350 | 2x 1,4 / 2x 0,7 | 15 | 0,65 |
| 2300 x 1500 | KR10B-600 | 2x 1,0 | 25 | 1,09 |

1.1.5.2. technical specification - top- and bottom-opening smoke exhaust windows opening outwards with chain actuators

| WINDOW SIZE** B' x H' | ACTUATOR* | POWER CONSUMPTION FOR 24 V- / 48 V-*** [A] | OPENING ANGLE [°] | ACTIVE AERODYNAMIC AREA [Aa] [m ²] |
|--------------------------|-------------|---|----------------------|---|
| [mm] | - | [A] | [°] | [m ²] |
| 2300 x 1500 | KR10B-500 | 2x 1,0 | 21 | 0,97 |
| 2300 x 1500 | KR10B-400 | 2x 1,0 | 17 | 0,79 |
| 2300 x 1500 | HCV500/1000 | 2x 1,4 / 2x 0,7 | 42 | 1,49 |
| 2300 x 1500 | HCV500/800 | 2x 1,4 / 2x 0,7 | 33 | 1,31 |
| 2300 x 1500 | HCV500/600 | 2x 1,4 / 2x 0,7 | 25 | 1,08 |
| 2300 x 1500 | HCV500/350 | 2x 1,4 / 2x 0,7 | 14 | 0,67 |
| 2400 x 800 | KR10B-500 | 2x 1,0 | 42 | 0,70 |
| 2400 x 800 | KR10B-400 | 2x 1,0 | 34 | 0,59 |
| 2400 x 800 | HCV500/1000 | 2x 1,4 / 2x 0,7 | 92 | 0,99 |
| 2400 x 800 | HCV500/800 | 2x 1,4 / 2x 0,7 | 70 | 0,92 |
| 2400 x 800 | HCV500/600 | 2x 1,4 / 2x 0,7 | 51 | 0,78 |
| 2400 x 800 | HCV500/350 | 2x 1,4 / 2x 0,7 | 29 | 0,53 |
| 2400 x 900 | KR10B-500 | 2x 1,0 | 37 | 0,75 |
| 2400 x 900 | KR10B-400 | 2x 1,0 | 29 | 0,63 |
| 2400 x 900 | HCV500/1000 | 2x 1,4 / 2x 0,7 | 78 | 1,10 |
| 2400 x 900 | HCV500/800 | 2x 1,4 / 2x 0,7 | 60 | 0,99 |
| 2400 x 900 | HCV500/600 | 2x 1,4 / 2x 0,7 | 44 | 0,84 |
| 2400 x 900 | HCV500/350 | 2x 1,4 / 2x 0,7 | 25 | 0,56 |
| 2400 x 1000 | KR10B-500 | 2x 1,0 | 33 | 0,78 |
| 2400 x 1000 | KR10B-400 | 2x 1,0 | 26 | 0,66 |
| 2400 x 1000 | HCV500/1000 | 2x 1,4 / 2x 0,7 | 68 | 1,18 |
| 2400 x 1000 | HCV500/800 | 2x 1,4 / 2x 0,7 | 53 | 1,05 |
| 2400 x 1000 | HCV500/600 | 2x 1,4 / 2x 0,7 | 39 | 0,89 |
| 2400 x 1000 | HCV500/350 | 2x 1,4 / 2x 0,7 | 22 | 0,59 |
| 2400 x 1100 | KR10B-500 | 2x 1,0 | 29 | 0,82 |
| 2400 x 1100 | KR10B-400 | 2x 1,0 | 23 | 0,69 |
| 2400 x 1100 | HCV500/1000 | 2x 1,4 / 2x 0,7 | 60 | 1,25 |
| 2400 x 1100 | HCV500/800 | 2x 1,4 / 2x 0,7 | 47 | 1,11 |
| 2400 x 1100 | HCV500/600 | 2x 1,4 / 2x 0,7 | 35 | 0,93 |
| 2400 x 1100 | HCV500/350 | 2x 1,4 / 2x 0,7 | 20 | 0,62 |
| 2400 x 1200 | KR10B-500 | 2x 1,0 | 26 | 0,86 |
| 2400 x 1200 | KR10B-400 | 2x 1,0 | 21 | 0,74 |
| 2400 x 1200 | HCV500/1000 | 2x 1,4 / 2x 0,7 | 54 | 1,33 |
| 2400 x 1200 | HCV500/800 | 2x 1,4 / 2x 0,7 | 43 | 1,18 |
| 2400 x 1200 | HCV500/600 | 2x 1,4 / 2x 0,7 | 32 | 0,98 |
| 2400 x 1200 | HCV500/350 | 2x 1,4 / 2x 0,7 | 18 | 0,64 |
| 2400 x 1300 | KR10B-600 | 2x 1,0 | 29 | 1,03 |
| 2400 x 1300 | KR10B-500 | 2x 1,0 | 24 | 0,91 |
| 2400 x 1300 | KR10B-400 | 2x 1,0 | 19 | 0,77 |
| 2400 x 1300 | HCV500/1000 | 2x 1,4 / 2x 0,7 | 49 | 1,40 |
| 2400 x 1300 | HCV500/800 | 2x 1,4 / 2x 0,7 | 39 | 1,25 |
| 2400 x 1300 | HCV500/600 | 2x 1,4 / 2x 0,7 | 29 | 1,03 |
| 2400 x 1300 | HCV500/350 | 2x 1,4 / 2x 0,7 | 17 | 0,65 |
| 2400 x 1400 | KR10B-600 | 2x 1,0 | 27 | 1,08 |

| WINDOW SIZE** B' x H' | ACTUATOR* | POWER CONSUMPTION FOR 24 V- / 48 V-*** [A] | OPENING ANGLE [°] | ACTIVE AERODYNAMIC AREA [Aa] [m ²] |
|--------------------------|-------------|---|----------------------|---|
| [mm] | - | [A] | [°] | [m ²] |
| 2400 x 1400 | KR10B-500 | 2x 1,0 | 22 | 0,95 |
| 2400 x 1400 | KR10B-400 | 2x 1,0 | 18 | 0,79 |
| 2400 x 1400 | HCV500/1000 | 2x 1,4 / 2x 0,7 | 45 | 1,48 |
| 2400 x 1400 | HCV500/800 | 2x 1,4 / 2x 0,7 | 36 | 1,30 |
| 2400 x 1400 | HCV500/600 | 2x 1,4 / 2x 0,7 | 27 | 1,07 |
| 2400 x 1400 | HCV500/350 | 2x 1,4 / 2x 0,7 | 15 | 0,67 |
| 2500 x 800 | KR10B-400 | 2x 1,0 | 34 | 0,62 |
| 2500 x 800 | HCV500/1000 | 2x 1,4 / 2x 0,7 | 92 | 1,04 |
| 2500 x 800 | HCV500/800 | 2x 1,4 / 2x 0,7 | 70 | 0,96 |
| 2500 x 800 | HCV500/600 | 2x 1,4 / 2x 0,7 | 51 | 0,81 |
| 2500 x 800 | HCV500/350 | 2x 1,4 / 2x 0,7 | 29 | 0,55 |
| 2500 x 900 | KR10B-500 | 2x 1,0 | 37 | 0,77 |
| 2500 x 900 | KR10B-400 | 2x 1,0 | 29 | 0,65 |
| 2500 x 900 | HCV500/1000 | 2x 1,4 / 2x 0,7 | 78 | 1,15 |
| 2500 x 900 | HCV500/800 | 2x 1,4 / 2x 0,7 | 60 | 1,03 |
| 2500 x 900 | HCV500/600 | 2x 1,4 / 2x 0,7 | 44 | 0,87 |
| 2500 x 900 | HCV500/350 | 2x 1,4 / 2x 0,7 | 25 | 0,58 |
| 2500 x 1000 | KR10B-500 | 2x 1,0 | 33 | 0,81 |
| 2500 x 1000 | KR10B-400 | 2x 1,0 | 26 | 0,68 |
| 2500 x 1000 | HCV500/1000 | 2x 1,4 / 2x 0,7 | 68 | 1,23 |
| 2500 x 1000 | HCV500/800 | 2x 1,4 / 2x 0,7 | 53 | 1,09 |
| 2500 x 1000 | HCV500/600 | 2x 1,4 / 2x 0,7 | 39 | 0,93 |
| 2500 x 1000 | HCV500/350 | 2x 1,4 / 2x 0,7 | 22 | 0,61 |
| 2500 x 1100 | KR10B-500 | 2x 1,0 | 29 | 0,85 |
| 2500 x 1100 | KR10B-400 | 2x 1,0 | 23 | 0,72 |
| 2500 x 1100 | HCV500/1000 | 2x 1,4 / 2x 0,7 | 60 | 1,31 |
| 2500 x 1100 | HCV500/800 | 2x 1,4 / 2x 0,7 | 47 | 1,16 |
| 2500 x 1100 | HCV500/600 | 2x 1,4 / 2x 0,7 | 35 | 0,97 |
| 2500 x 1100 | HCV500/350 | 2x 1,4 / 2x 0,7 | 20 | 0,65 |
| 2500 x 1200 | KR10B-500 | 2x 1,0 | 26 | 0,90 |
| 2500 x 1200 | KR10B-400 | 2x 1,0 | 21 | 0,77 |
| 2500 x 1200 | HCV500/1000 | 2x 1,4 / 2x 0,7 | 54 | 1,38 |
| 2500 x 1200 | HCV500/800 | 2x 1,4 / 2x 0,7 | 43 | 1,23 |
| 2500 x 1200 | HCV500/600 | 2x 1,4 / 2x 0,7 | 32 | 1,02 |
| 2500 x 1200 | HCV500/350 | 2x 1,4 / 2x 0,7 | 18 | 0,66 |
| 2500 x 1300 | KR10B-500 | 2x 1,0 | 24 | 0,94 |
| 2500 x 1300 | KR10B-400 | 2x 1,0 | 19 | 0,80 |
| 2500 x 1300 | HCV500/1000 | 2x 1,4 / 2x 0,7 | 49 | 1,46 |
| 2500 x 1300 | HCV500/800 | 2x 1,4 / 2x 0,7 | 39 | 1,30 |
| 2500 x 1300 | HCV500/600 | 2x 1,4 / 2x 0,7 | 29 | 1,06 |
| 2500 x 1300 | HCV500/350 | 2x 1,4 / 2x 0,7 | 17 | 0,68 |
| 2500 x 1400 | KR10B-500 | 2x 1,0 | 22 | 0,99 |
| 2500 x 1400 | KR10B-400 | 2x 1,0 | 18 | 0,82 |
| 2500 x 1400 | HCV500/1000 | 2x 1,4 / 2x 0,7 | 45 | 1,54 |

1.1.5.2. technical specification - top- and bottom-opening smoke exhaust windows opening outwards with chain actuators

| WINDOW SIZE** | ACTUATOR* | POWER CONSUMPTION FOR 24 V- / 48 V-*** | OPENING ANGLE | ACTIVE AERODYNAMIC AREA [Aa] |
|---------------|-------------|--|---------------|------------------------------|
| B' x H' | | | | |
| [mm] | - | [A] | [°] | [m ²] |
| 2500 x 1400 | HCV500/800 | 2x 1,4 / 2x 0,7 | 36 | 1,35 |
| 2500 x 1400 | HCV500/600 | 2x 1,4 / 2x 0,7 | 27 | 1,12 |
| 2500 x 1400 | HCV500/350 | 2x 1,4 / 2x 0,7 | 15 | 0,70 |
| 2600 x 800 | KR10B-400 | 2x 1,0 | 34 | 0,64 |
| 2600 x 800 | HCV500/1000 | 2x 1,4 / 2x 0,7 | 92 | 1,08 |
| 2600 x 800 | HCV500/800 | 2x 1,4 / 2x 0,7 | 70 | 0,99 |
| 2600 x 800 | HCV500/600 | 2x 1,4 / 2x 0,7 | 51 | 0,84 |
| 2600 x 800 | HCV500/350 | 2x 1,4 / 2x 0,7 | 29 | 0,57 |
| 2600 x 900 | KR10B-500 | 2x 1,0 | 37 | 0,81 |
| 2600 x 900 | KR10B-400 | 2x 1,0 | 29 | 0,68 |
| 2600 x 900 | HCV500/1000 | 2x 1,4 / 2x 0,7 | 78 | 1,20 |
| 2600 x 900 | HCV500/800 | 2x 1,4 / 2x 0,7 | 60 | 1,07 |
| 2600 x 900 | HCV500/600 | 2x 1,4 / 2x 0,7 | 44 | 0,91 |
| 2600 x 900 | HCV500/350 | 2x 1,4 / 2x 0,7 | 25 | 0,60 |
| 2600 x 1000 | KR10B-500 | 2x 1,0 | 33 | 0,84 |
| 2600 x 1000 | KR10B-400 | 2x 1,0 | 26 | 0,71 |
| 2600 x 1000 | HCV500/1000 | 2x 1,4 / 2x 0,7 | 68 | 1,28 |
| 2600 x 1000 | HCV500/800 | 2x 1,4 / 2x 0,7 | 53 | 1,14 |
| 2600 x 1000 | HCV500/600 | 2x 1,4 / 2x 0,7 | 39 | 0,97 |
| 2600 x 1000 | HCV500/350 | 2x 1,4 / 2x 0,7 | 22 | 0,64 |
| 2600 x 1100 | KR10B-500 | 2x 1,0 | 29 | 0,89 |
| 2600 x 1100 | KR10B-400 | 2x 1,0 | 23 | 0,75 |
| 2600 x 1100 | HCV500/1000 | 2x 1,4 / 2x 0,7 | 60 | 1,37 |
| 2600 x 1100 | HCV500/800 | 2x 1,4 / 2x 0,7 | 47 | 1,21 |
| 2600 x 1100 | HCV500/600 | 2x 1,4 / 2x 0,7 | 35 | 1,01 |
| 2600 x 1100 | HCV500/350 | 2x 1,4 / 2x 0,7 | 20 | 0,68 |
| 2600 x 1200 | KR10B-500 | 2x 1,0 | 26 | 0,93 |
| 2600 x 1200 | KR10B-400 | 2x 1,0 | 21 | 0,79 |
| 2600 x 1200 | HCV500/1000 | 2x 1,4 / 2x 0,7 | 54 | 1,44 |
| 2600 x 1200 | HCV500/800 | 2x 1,4 / 2x 0,7 | 43 | 1,28 |
| 2600 x 1200 | HCV500/600 | 2x 1,4 / 2x 0,7 | 32 | 1,05 |
| 2600 x 1200 | HCV500/350 | 2x 1,4 / 2x 0,7 | 18 | 0,69 |
| 2600 x 1300 | KR10B-500 | 2x 1,0 | 24 | 0,98 |
| 2600 x 1300 | KR10B-400 | 2x 1,0 | 19 | 0,83 |
| 2600 x 1300 | HCV500/1000 | 2x 1,4 / 2x 0,7 | 49 | 1,52 |
| 2600 x 1300 | HCV500/800 | 2x 1,4 / 2x 0,7 | 39 | 1,35 |
| 2600 x 1300 | HCV500/600 | 2x 1,4 / 2x 0,7 | 29 | 1,10 |
| 2600 x 1300 | HCV500/350 | 2x 1,4 / 2x 0,7 | 17 | 0,70 |
| 2700 x 800 | KR10B-400 | 2x 1,0 | 34 | 0,67 |
| 2700 x 800 | HCV500/1000 | 2x 1,4 / 2x 0,7 | 92 | 1,13 |
| 2700 x 800 | HCV500/800 | 2x 1,4 / 2x 0,7 | 70 | 1,04 |
| 2700 x 800 | HCV500/600 | 2x 1,4 / 2x 0,7 | 51 | 0,88 |
| 2700 x 800 | HCV500/350 | 2x 1,4 / 2x 0,7 | 29 | 0,59 |
| 2700 x 900 | KR10B-500 | 2x 1,0 | 37 | 0,84 |

| WINDOW SIZE** | ACTUATOR* | POWER CONSUMPTION FOR 24 V- / 48 V-*** | OPENING ANGLE | ACTIVE AERODYNAMIC AREA [Aa] |
|---------------|-------------|--|---------------|------------------------------|
| B' x H' | | | | |
| [mm] | - | [A] | [°] | [m ²] |
| 2700 x 900 | KR10B-400 | 2x 1,0 | 29 | 0,70 |
| 2700 x 900 | HCV500/1000 | 2x 1,4 / 2x 0,7 | 78 | 1,25 |
| 2700 x 900 | HCV500/800 | 2x 1,4 / 2x 0,7 | 60 | 1,11 |
| 2700 x 900 | HCV500/600 | 2x 1,4 / 2x 0,7 | 44 | 0,94 |
| 2700 x 900 | HCV500/350 | 2x 1,4 / 2x 0,7 | 25 | 0,63 |
| 2700 x 1000 | KR10B-500 | 2x 1,0 | 33 | 0,88 |
| 2700 x 1000 | KR10B-400 | 2x 1,0 | 26 | 0,74 |
| 2700 x 1000 | HCV500/1000 | 2x 1,4 / 2x 0,7 | 68 | 1,34 |
| 2700 x 1000 | HCV500/800 | 2x 1,4 / 2x 0,7 | 53 | 1,19 |
| 2700 x 1000 | HCV500/600 | 2x 1,4 / 2x 0,7 | 39 | 1,00 |
| 2700 x 1000 | HCV500/350 | 2x 1,4 / 2x 0,7 | 22 | 0,66 |
| 2700 x 1100 | KR10B-500 | 2x 1,0 | 29 | 0,92 |
| 2700 x 1100 | KR10B-400 | 2x 1,0 | 23 | 0,78 |
| 2700 x 1100 | HCV500/1000 | 2x 1,4 / 2x 0,7 | 60 | 1,42 |
| 2700 x 1100 | HCV500/800 | 2x 1,4 / 2x 0,7 | 47 | 1,25 |
| 2700 x 1100 | HCV500/600 | 2x 1,4 / 2x 0,7 | 35 | 1,04 |
| 2700 x 1100 | HCV500/350 | 2x 1,4 / 2x 0,7 | 20 | 0,70 |
| 2700 x 1200 | KR10B-500 | 2x 1,0 | 26 | 0,96 |
| 2700 x 1200 | KR10B-400 | 2x 1,0 | 21 | 0,82 |
| 2700 x 1200 | HCV500/1000 | 2x 1,4 / 2x 0,7 | 54 | 1,49 |
| 2700 x 1200 | HCV500/800 | 2x 1,4 / 2x 0,7 | 43 | 1,33 |
| 2700 x 1200 | HCV500/600 | 2x 1,4 / 2x 0,7 | 32 | 1,09 |
| 2700 x 1200 | HCV500/350 | 2x 1,4 / 2x 0,7 | 18 | 0,71 |
| 2700 x 1300 | KR10B-500 | 2x 1,0 | 24 | 1,01 |
| 2700 x 1300 | KR10B-400 | 2x 1,0 | 19 | 0,86 |
| 2700 x 1300 | HCV500/1000 | 2x 1,4 / 2x 0,7 | 49 | 1,58 |
| 2700 x 1300 | HCV500/800 | 2x 1,4 / 2x 0,7 | 39 | 1,40 |
| 2700 x 1300 | HCV500/600 | 2x 1,4 / 2x 0,7 | 29 | 1,15 |
| 2700 x 1300 | HCV500/350 | 2x 1,4 / 2x 0,7 | 17 | 0,73 |

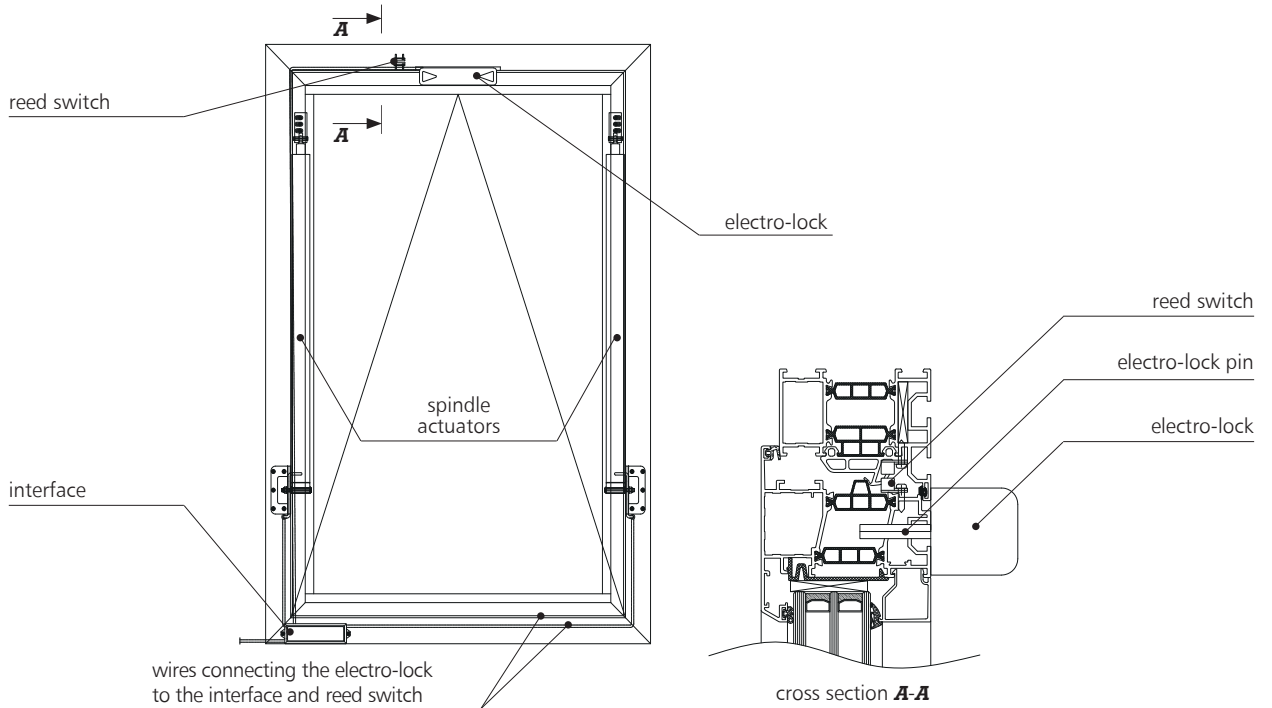
(*) Actuators of type HCV 500/xxx may be supplied with 24V- or 48V-. HCVA 500/xxx actuator with voltage 230V~ and power consumption 0.13A may be used as an equivalent of each specified HCV 500/xxx actuator. KR10B actuators are supplied with 24V-.

(**) It is possible to make intermediate dimensions of the smoke exhaust window between the values given in the table. The size of the active aerodynamic area for these dimensions is determined by linear interpolation.

(***) Power consumption given for the list of actuators used in a given smoke exhaust window.

1.1.6. technical specification - application of electro-lock in windows with spindle actuators

The automatic electro-lock for smoke exhausting windows as well as daily ventilation windows provides protection and safety. It is mounted in place of the handle, and after receiving 24 V voltage its pin rotates and moves the peripheral hardware. This guarantees resistance of the leaf against wind load and suitable, tamper-proof leaf-to-frame connection. The electro-lock works with the: interface, reed switch and the actuators. Standard peripheral hardware is used for installation. Electro-lock specification: 24 V-; 1.0 A; 10 Nm.



| | | H' - window height [mm] | | | | | | | | | | | | | | | |
|------------------------|------|-------------------------|-----|------|------|------|------|------|------|------|------|------|------|------|------|------|---|
| | | 800 | 900 | 1000 | 1100 | 1200 | 1300 | 1400 | 1500 | 1600 | 1700 | 1800 | 1900 | 2000 | 2100 | 2200 | |
| B' - window width [mm] | 800 | | | | | | | | | • | • | • | • | • | • | • | |
| | 900 | | | | | | | | | • | • | • | • | • | • | • | |
| | 1000 | | | | | | | | | • | • | • | • | • | • | • | |
| | 1100 | | | | | | | | | • | • | • | • | • | • | • | |
| | 1200 | | | | | | | | | • | • | • | • | • | • | • | |
| | 1300 | | | | | | | | | • | • | • | • | • | • | • | |
| | 1400 | | | | | | | | | • | • | • | • | • | • | • | |
| | 1500 | | | | | | | | | • | • | • | • | • | • | • | |
| | 1600 | | | | | | | | • | • | • | • | • | • | • | • | • |
| | 1700 | | | | | | | • | • | • | • | • | • | • | • | • | • |
| | 1800 | | | | | | | • | • | • | • | • | • | • | • | • | • |
| | 1900 | | | | | | | • | • | • | • | • | • | • | • | • | • |
| | 2000 | | | | | | | • | • | • | • | • | • | • | • | • | • |
| | 2100 | • | • | • | • | • | • | • | • | • | • | • | • | • | • | • | • |
| | 2200 | • | • | • | • | • | • | • | • | • | • | • | • | • | • | • | • |
| | 2300 | • | • | • | • | • | • | • | • | • | • | • | • | • | • | • | • |
| | 2400 | • | • | • | • | • | • | • | • | • | • | • | • | • | • | • | • |
| 2500 | • | • | • | • | • | • | • | • | • | • | • | • | • | • | • | • | |
| 2600 | • | • | • | • | • | • | • | • | • | • | • | • | • | • | • | • | |
| 2700 | • | • | • | • | • | • | • | • | • | • | • | • | • | • | • | • | |

- dimensional range of electro-lock windows
- dimensional range of windows without electro-lock
- area beyond availability

1.2. inward-opening smoke exhaust windows

1.2.1. description of standard

- classification according to the Certificate of Constancy of Performance No 1396-CPR-0128 (according to EN 12101-2:2003)
- inward-opening smoke exhaust windows intended for installation in the facade as individual smoke exhaust and daily ventilation devices or integrated into post and beam facade systems available on the market
- dimensional range of inward-opening smoke exhaust windows in horizontal arrangement 800x800 mm ÷ 2700x1300 mm, in vertical arrangement 800x800 mm ÷ 1600x2200 mm
- smoke exhaust windows made of individually designed multi-chamber aluminium profiles with polyamide thermal breaks
- profile width: frame 75 mm and leaf 84 mm
- groove system in the leaf and frame profile with covering profile allows to route cables and install actuator consoles easily
- leaf glazing: triple glass 4/18/4/18/4 (heat transfer coefficient $U_g=0.5 \text{ W / (m}^2\text{K)}$), triple safety glass 4/18/4/18/33.1 ($U_g=0.5 \text{ W (m}^2\text{K)}$), double safety glass 4/16/33.1 ($U_g= 1.1 \text{ W / (m}^2\text{K)}$) or sandwich panel (ALU-PIR-ALU) ($U_g=0.66 \text{ W / (m}^2\text{K)}$)
- windows joined with each other by means of vertical or horizontal connection sets
- leaf opening angle $10^\circ \div 90^\circ$ (depending on the size of the window and type of control used)
- exhaust or daily ventilation control: 24 V- / 48 V- power supply (G / S spindle actuators, KR10B / HCV chain actuators) or 230 V~ (HCVA chain actuators)
- use of an electro-lock with interface for the selected dimensional range of smoke exhaust windows with spindle actuators (see page 71 for table of dimensions with electro lock)

1.2.2. options of making

- possibility of making intermediate dimensions of smoke exhaust windows between the values given in the table on pages 50-71, the value of the active aerodynamic area for these dimensions is calculated by linear interpolation
- possibility of painting profiles in any RAL colour; structural or wood imitation colour
- possibility of making bi-colour windows
- glazing beads available in rectangular or rounded versions
- decorative bars referring to the style of old architecture as well as a modern element of architecture:
 - stuck on - glued to the glazing unit both inside and outside
 - internal - placed inside the glazing unit
- glazing bars - dividing the glass into many smaller formats

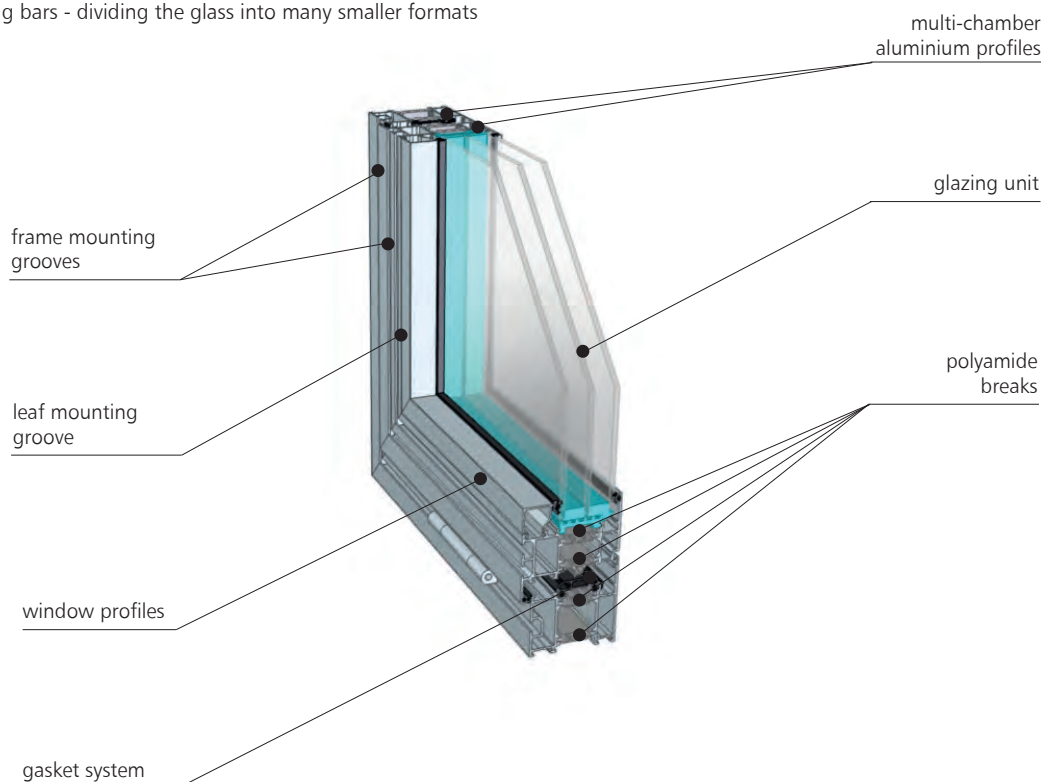


Fig. 54 - Cross-section through the profile of an inward-opening smoke exhaust window

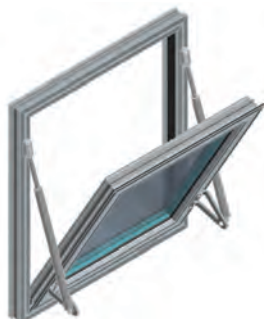
1.2.3. types of inward-opening smoke exhaust windows**bottom hung inward-opening windows**

Fig. 55 - mcr OSO THERM 75 smoke exhaust window with two S spindle actuators

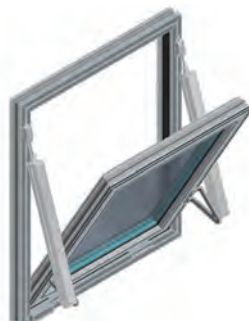


Fig. 56 - mcr OSO THERM 75 smoke exhaust window with two G spindle actuators



Fig. 57 - mcr OSO THERM 75 smoke exhaust window with KR10B / HCV chain actuator

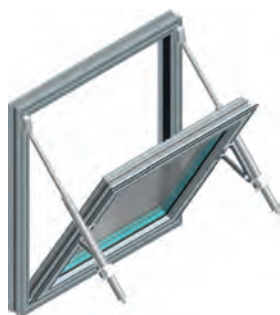


Fig. 58 - mcr OSO THERM 75 smoke exhaust window with two S spindle actuators with shifted pivot point

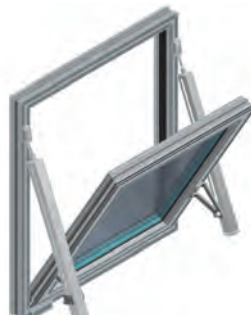


Fig. 59 - mcr OSO THERM 75 smoke exhaust window with two G spindle actuators with shifted pivot point



Fig. 60 - mcr OSO THERM 75 smoke exhaust window with two KR10B / HCV chain actuators

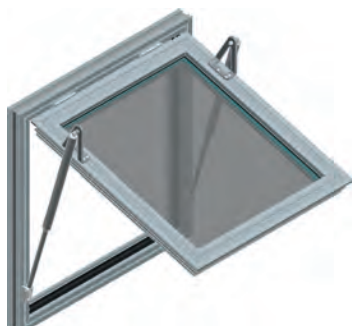
top hung inward-opening windows

Fig. 61 - mcr OSO THERM 75 smoke exhaust window with two S spindle actuators

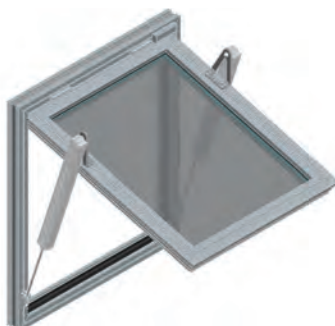


Fig. 62 - mcr OSO THERM 75 smoke exhaust window with two G spindle actuators

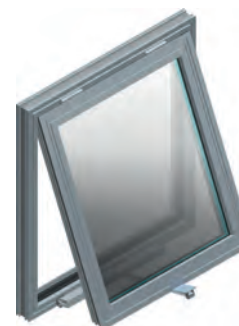


Fig. 63 - mcr OSO THERM 75 smoke exhaust window with KR10B / HCV chain actuator



Fig. 64 - mcr OSO THERM 75 smoke exhaust window with two S spindle actuators with shifted pivot point



Fig. 65 - mcr OSO THERM 75 smoke exhaust window with two G spindle actuators with shifted pivot point



Fig. 66 - mcr OSO THERM 75 smoke exhaust window with two KR10B / HCV chain actuators

1.2.3.1. design of inward opening smoke exhaust window with spindle actuators

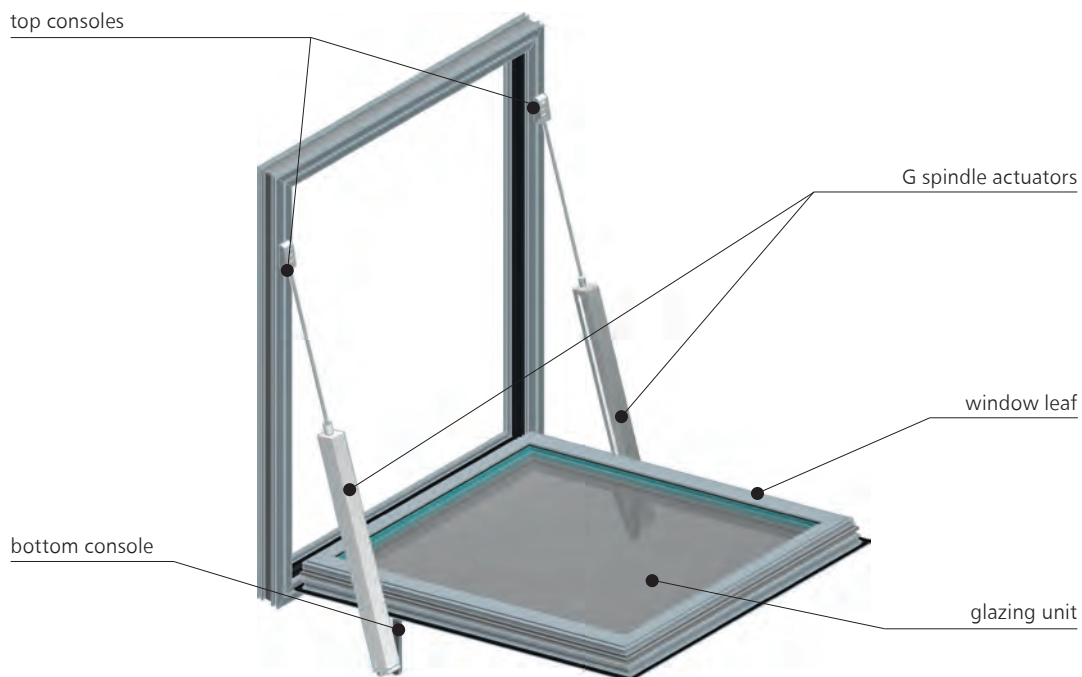


Fig. 67 - mcr OSO THERM 75 smoke exhaust window opening inwards by means of two spindle actuators

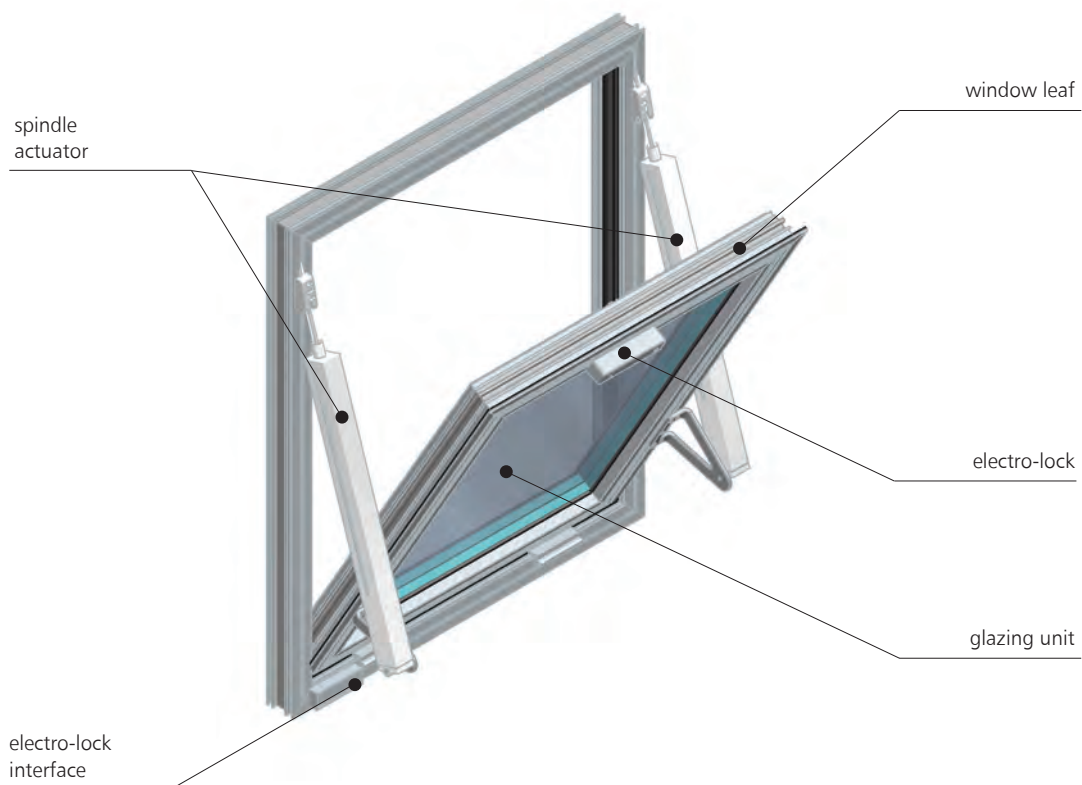


Fig. 68 - mcr OSO THERM 75 smoke exhaust window opening inwards by means of two G spindle actuators with electro-lock and interface

1.2.3.2. design of smoke exhaust window opening inwards by means of chain actuators

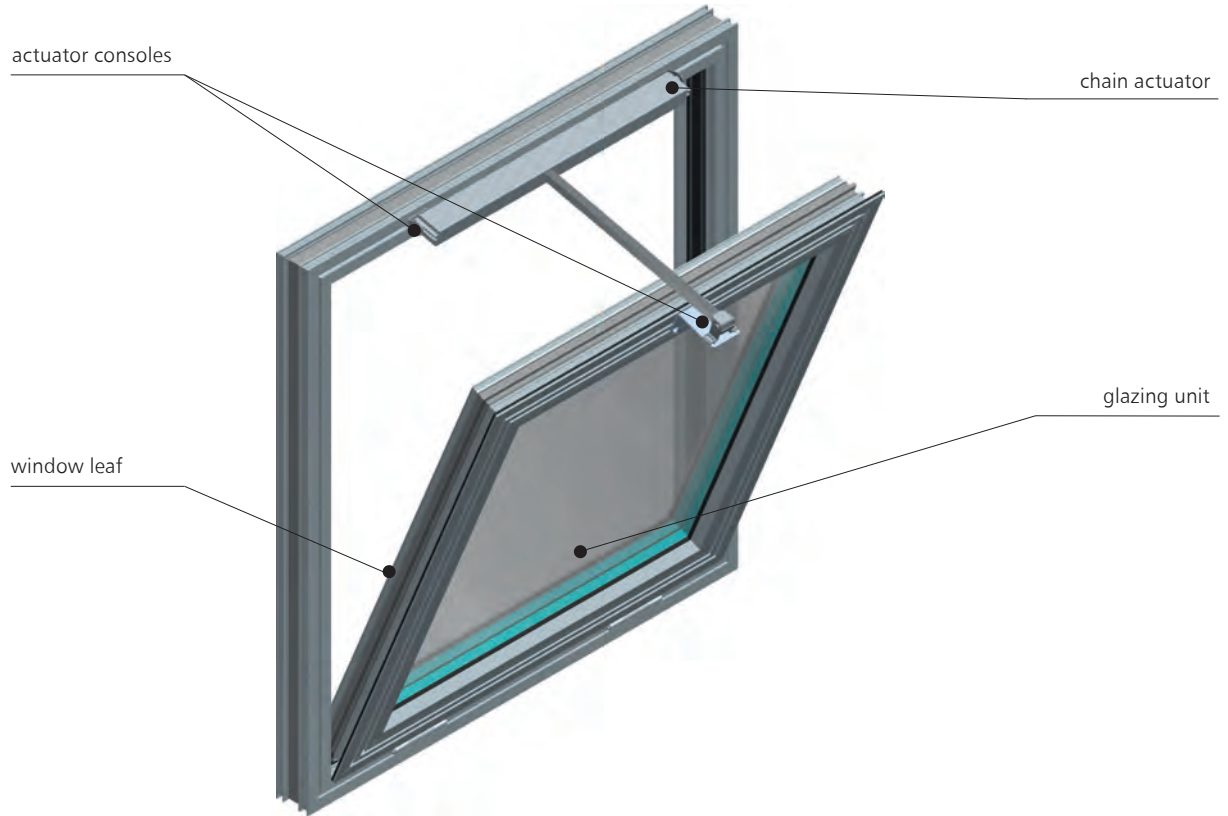


Fig. 69 - mcr OSO THERM 75 smoke exhaust window opening inwards by means of single KR10B chain actuator

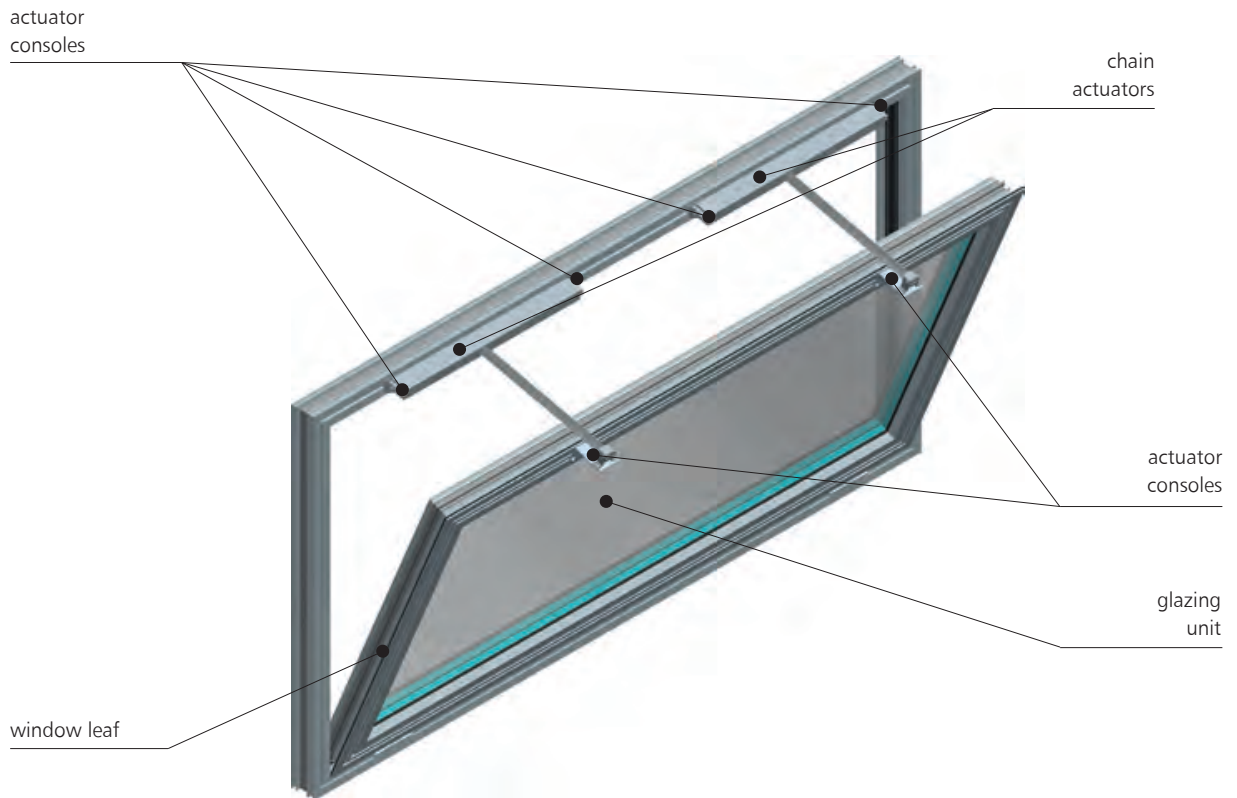


Fig. 70 - mcr OSO THERM 75 smoke exhaust window opening inwards by means of double KR10B chain actuators

1.2.4. technical drawings of inward opening smoke exhaust windows

1.2.4.1. technical drawings of the smoke exhaust window with S spindle actuators

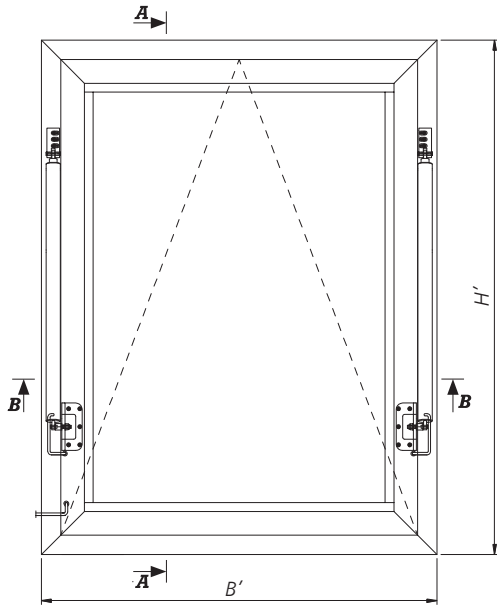


Fig. 71 - view from inside the mcr OSO THERM 75 smoke exhaust window with S spindle actuators in closed position

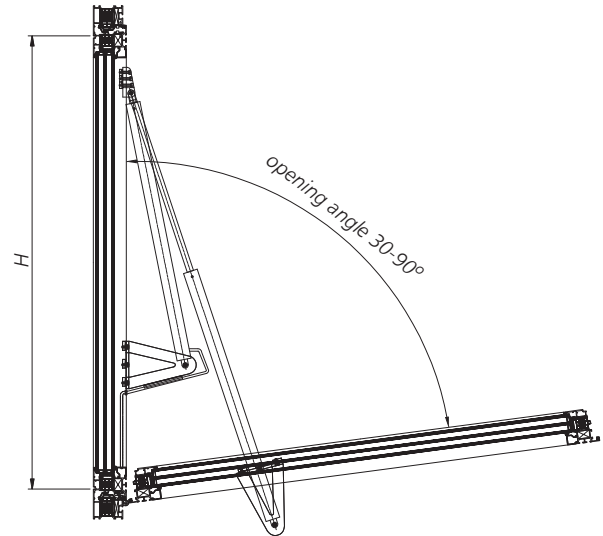


Fig. 72 - A-A vertical cross-section through mcr OSO THERM 75 smoke exhaust window in open position

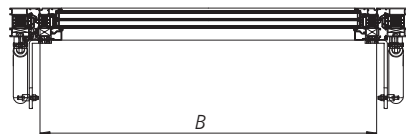


Fig. 73 - B-B horizontal cross-section through mcr OSO THERM 75 smoke exhaust window in closed position

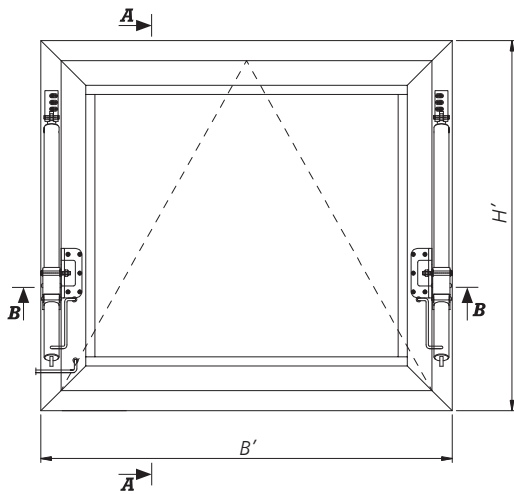


Fig. 74 - view from inside the mcr OSO THERM 75 smoke exhaust window with S spindle actuators with shifted pivot point in closed position

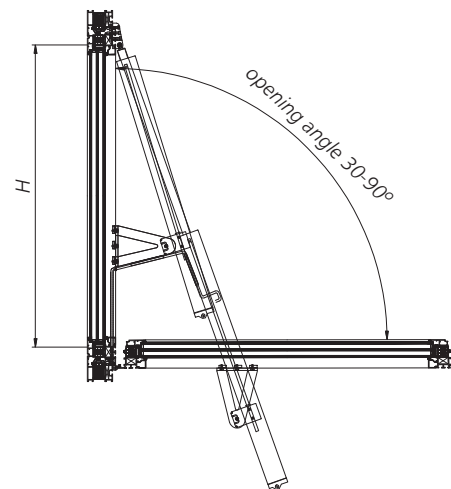


Fig. 75 - A-A vertical cross-section through mcr OSO THERM 75 smoke exhaust window with shifted pivot point in open position

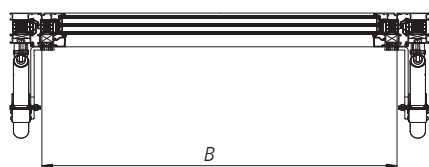


Fig. 76 - B-B horizontal cross-section through mcr OSO THERM 75 smoke exhaust window in closed position

B' - external width of the smoke exhaust window
 H' - external height of the smoke exhaust window
 B - internal width of the smoke exhaust window
 H - internal height of the smoke exhaust window

1.2.4.2. technical drawings of the smoke exhaust window with G spindle actuators

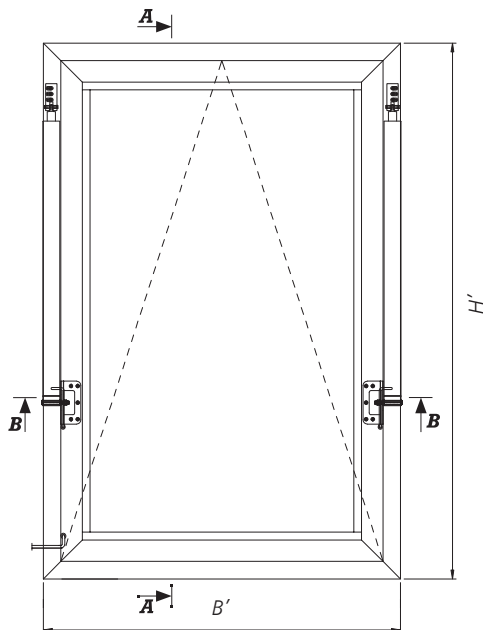


Fig. 77 - view from inside the mcr OSO THERM 75 smoke exhaust window with G spindle actuators in closed position

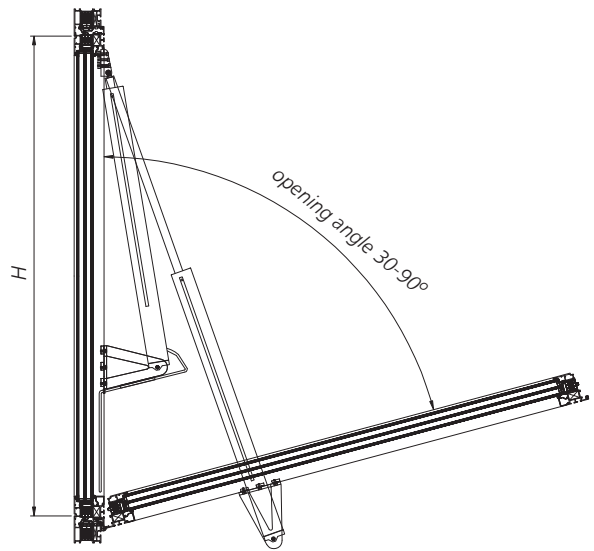


Fig. 78 - A-A vertical cross-section through mcr OSO THERM 75 smoke exhaust window in open position

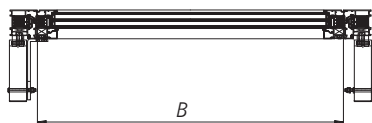


Fig. 79 - B-B horizontal cross-section through mcr OSO THERM 75 smoke exhaust window in closed position

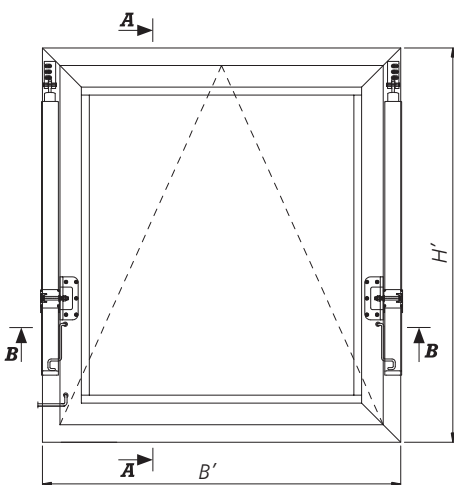


Fig. 80 - view from inside the mcr OSO THERM 75 smoke exhaust window with G spindle actuators with shifted pivot point in closed position

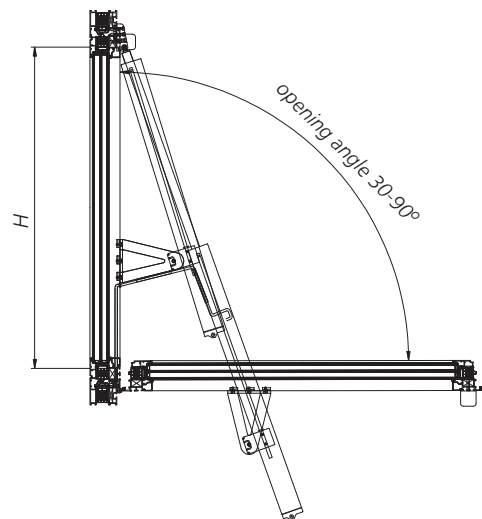


Fig. 81 - A-A vertical cross-section through mcr OSO THERM 75 smoke exhaust window with shifted pivot point in open position

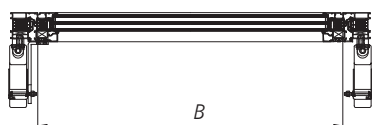


Fig. 82 - B-B horizontal cross-section through mcr OSO THERM 75 smoke exhaust window with shifted pivot point in closed position

B' - external width of the smoke exhaust window
 H' - external height of the smoke exhaust window
 B - internal width of the smoke exhaust window
 H - internal height of the smoke exhaust window

1.2.4.3. technical drawings of the smoke exhaust window with KR10B chain actuator

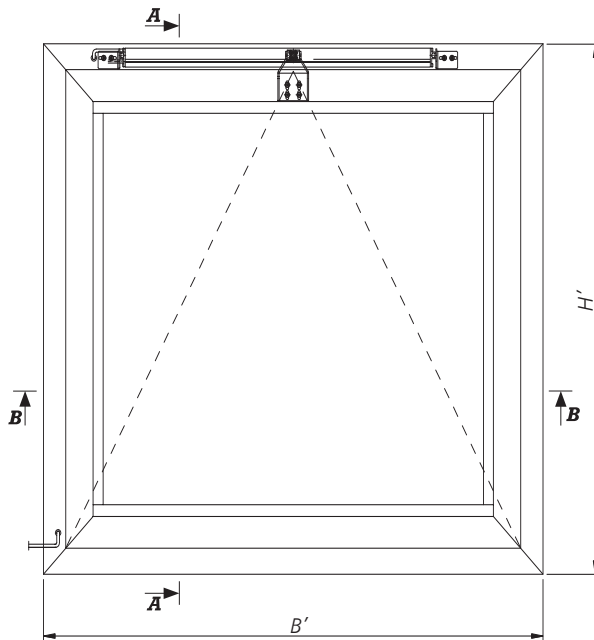


Fig. 83 - view from inside the mcr OSO THERM 75 smoke exhaust window with KR10B chain actuator in closed position

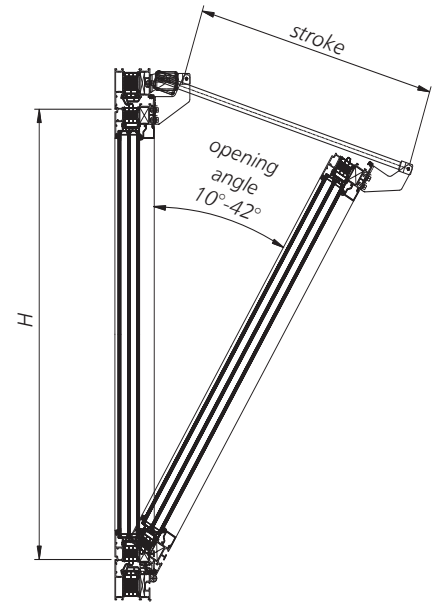


Fig. 84 - A-A vertical cross-section through mcr OSO THERM 75 smoke exhaust window in open position

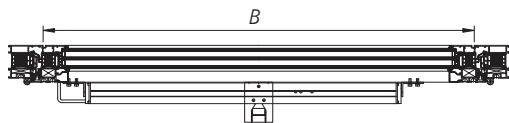


Fig. 85 - B-B horizontal cross-section through mcr OSO THERM 75 smoke exhaust window in closed position

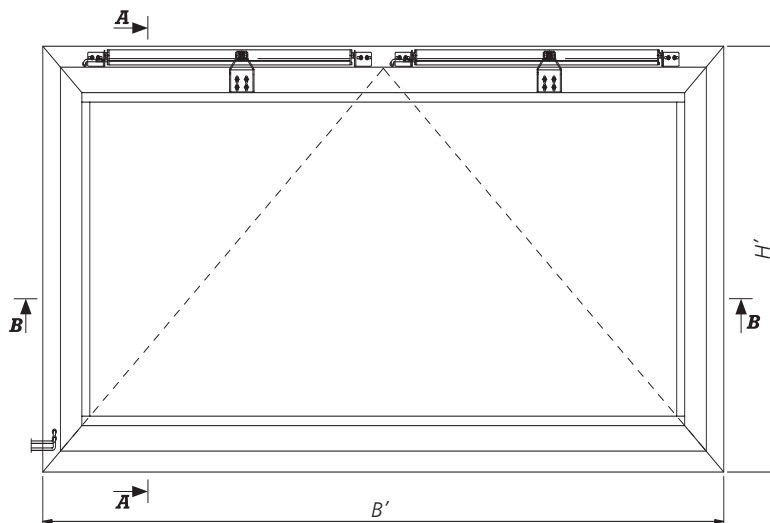


Fig. 86 - view from inside the mcr OSO THERM 75 smoke exhaust window with two KR10B chain actuators in closed position

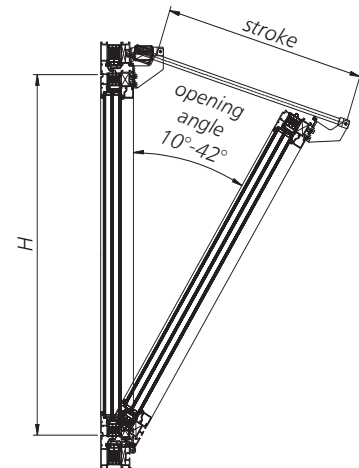


Fig. 87 - A-A vertical cross-section through mcr OSO THERM 75 smoke exhaust window in open position

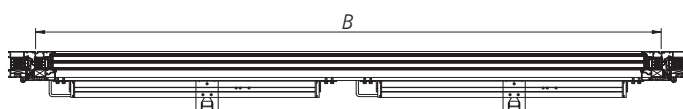


Fig. 88 - B-B horizontal cross-section through mcr OSO THERM 75 smoke exhaust window in closed position

B' - external width of the smoke exhaust window
 H' - external height of the smoke exhaust window
 B - internal width of the smoke exhaust window
 H - internal height of the smoke exhaust window

1.2.4.4. technical drawings of the smoke exhaust window with HCV chain actuator

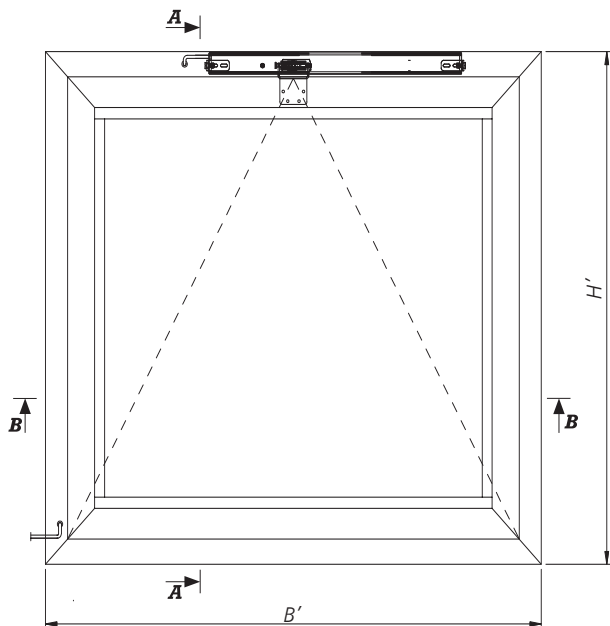


Fig. 89 - view from inside the mcr OSO THERM 75 smoke exhaust window with HCV chain actuator in closed position

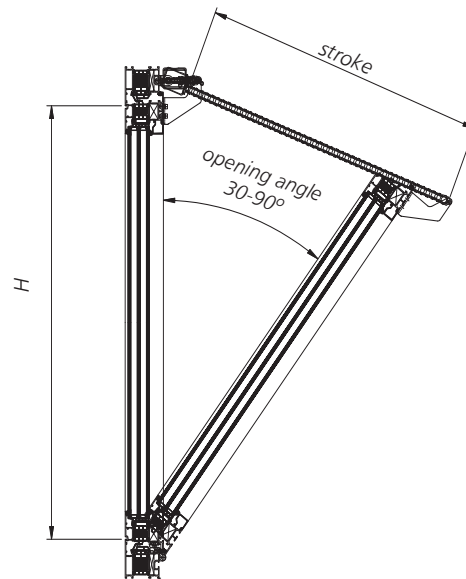


Fig. 90 - A-A vertical cross-section through mcr OSO THERM 75 smoke exhaust window in open position

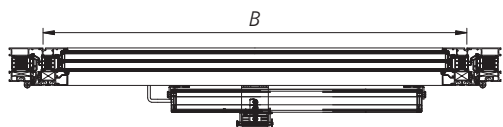


Fig. 91 - B-B horizontal cross-section through smoke exhaust window mcr OSO THERM 75 smoke exhaust window in closed position

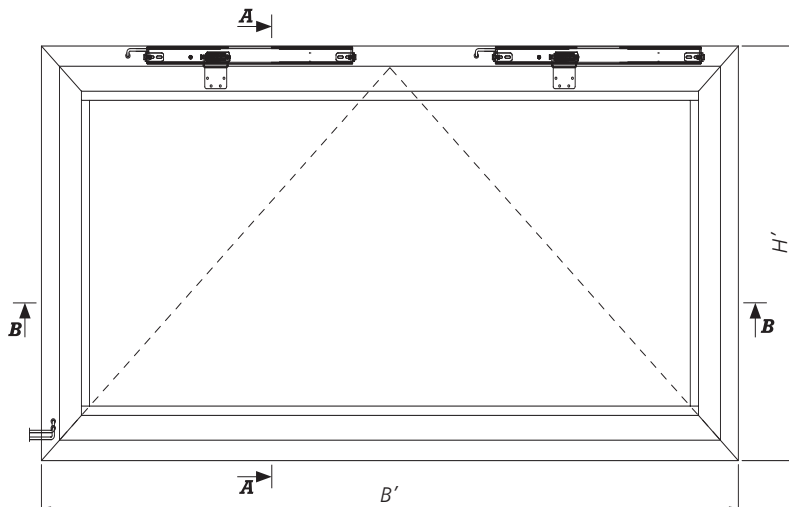


Fig. 92 - view from inside the mcr OSO THERM 75 smoke exhaust window with two HCV chain actuators in closed position

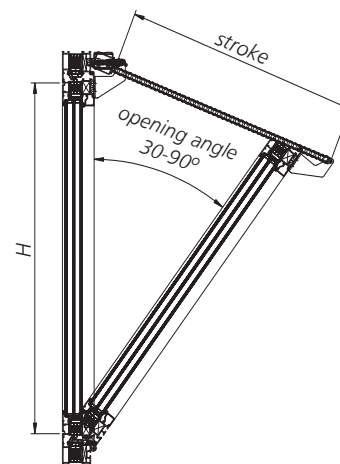


Fig. 93 - A-A vertical cross-section through mcr OSO THERM 75 smoke exhaust window in open position

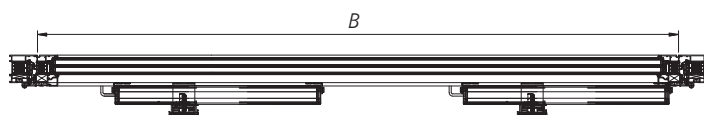


Fig. 94 - B-B horizontal cross-section through mcr OSO THERM 75 smoke exhaust window in closed position

B' - external width of the smoke exhaust window
 H' - external height of the smoke exhaust window
 B - internal width of the smoke exhaust window
 H - internal height of the smoke exhaust window

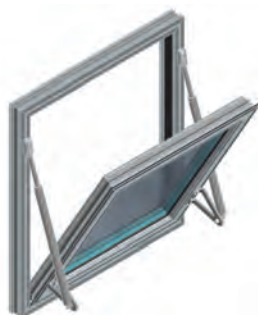
1.2.5. technical specification**1.2.5.1. types of smoke exhaust windows opening outwards by means of spindle actuators****bottom hung inward-opening windows**

Fig. 95 - mcr OSO THERM 75 smoke exhaust window with two S spindle actuators

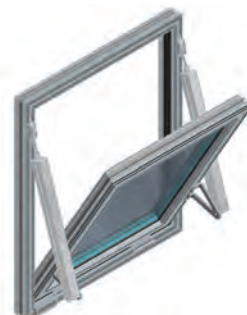


Fig. 96 - mcr OSO THERM 75 smoke exhaust window with two G spindle actuators

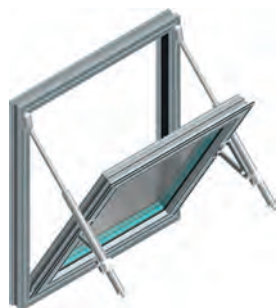


Fig. 97 - mcr OSO THERM 75 smoke exhaust window with two S spindle actuators with shifted pivot point

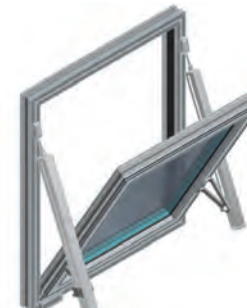


Fig. 98 - mcr OSO THERM 75 smoke exhaust window with two G spindle actuators with shifted pivot point

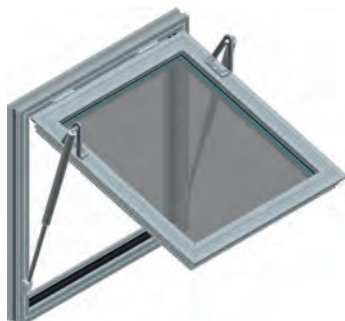
top-hung inward-opening windows

Fig. 99 - mcr OSO THERM 75 smoke exhaust window with two S spindle actuators

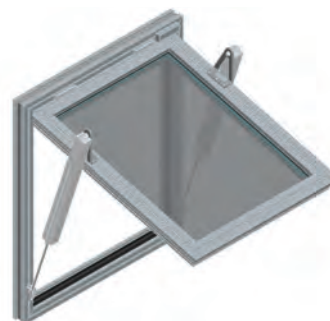


Fig. 100 - mcr OSO THERM 75 smoke exhaust window with two G spindle actuators



Fig. 101 - mcr OSO THERM 75 smoke exhaust window with two S spindle actuators with shifted pivot point

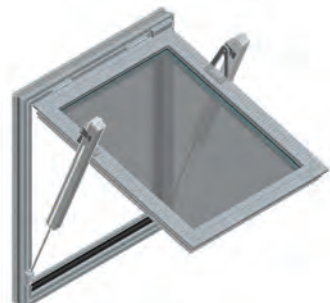


Fig. 102 - mcr OSO THERM 75 smoke exhaust window with two G spindle actuators with shifted pivot point

1.2.5.1. technical specification - types of smoke exhaust windows opening outwards by means of spindle actuators

| WINDOW SIZE* B' x H' | OPENING ANGLE 30° | | | OPENING ANGLE 45° | | | OPENING ANGLE 60° | | | OPENING ANGLE 75° | | | OPENING ANGLE 90° | | |
|-------------------------|-------------------|--------------------------|-----------------------------------|-------------------|--------------------------|-----------------------------------|-------------------|--------------------------|-----------------------------------|-------------------|--------------------------|-----------------------------------|-------------------|--------------------------|-----------------------------------|
| | ACTUATOR | POWER CON-SUMPTION** [A] | ACTIVE AERODYNAMIC AREA [Aa] [m²] | ACTUATOR | POWER CON-SUMPTION** [A] | ACTIVE AERODYNAMIC AREA [Aa] [m²] | ACTUATOR | POWER CON-SUMPTION** [A] | ACTIVE AERODYNAMIC AREA [Aa] [m²] | ACTUATOR | POWER CON-SUMPTION** [A] | ACTIVE AERODYNAMIC AREA [Aa] [m²] | ACTUATOR | POWER CON-SUMPTION** [A] | ACTIVE AERODYNAMIC AREA [Aa] [m²] |
| 800 x 800 | S08B-200 | 2x0,8 | 0,20 | S08B-300 | 2x0,8 | 0,25 | S08B-300 | 2x0,8 | 0,29 | S10C-400 | 2x1,0 | 0,30 | S10C-450 | 2x1,0 | 0,32 |
| 800 x 900 | S08B-200 | 2x0,8 | 0,23 | S08B-300 | 2x0,8 | 0,29 | S08B-300 | 2x0,8 | 0,33 | S10C-400 | 2x1,0 | 0,35 | S10C-450 | 2x1,0 | 0,37 |
| 800 x 1000 | S08B-200 | 2x0,8 | 0,27 | S08B-300 | 2x0,8 | 0,33 | S10C-400 | 2x1,0 | 0,38 | S08B-300 | 2x0,8 | 0,40 | S10C-450 | 2x1,0 | 0,42 |
| 800 x 1100 | S08B-200 | 2x0,8 | 0,30 | S10C-350 | 2x1,0 | 0,38 | S10C-400 | 2x1,0 | 0,43 | S10C-350 | 2x1,0 | 0,45 | G26H-550 | 2x2,6 | 0,47 |
| 800 x 1200 | S08B-300 | 2x0,8 | 0,34 | S08B-300 | 2x0,8 | 0,42 | S10C-350 | 2x1,0 | 0,47 | S10C-400 | 2x1,0 | 0,50 | G26H-550 | 2x2,6 | 0,52 |
| 800 x 1300 | S08B-300 | 2x0,8 | 0,38 | S10C-350 | 2x1,0 | 0,46 | S10C-400 | 2x1,0 | 0,52 | S10C-450 | 2x1,0 | 0,54 | S10C-450 | 2x1,0 | 0,57 |
| 800 x 1400 | S08B-300 | 2x0,8 | 0,42 | S10C-350 | 2x1,0 | 0,51 | S10C-450 | 2x1,0 | 0,57 | S10C-450 | 2x1,0 | 0,60 | G26H-750 | 2x2,6 | 0,61 |
| 800 x 1500 | S08B-300 | 2x0,8 | 0,46 | S10C-400 | 2x1,0 | 0,56 | S10C-450 | 2x1,0 | 0,62 | G26H-550 | 2x2,6 | 0,65 | G26H-750 | 2x2,6 | 0,67 |
| 800 x 1600 | S10C-350 | 2x1,0 | 0,50 | S10C-450 | 2x1,0 | 0,61 | G26H-550 | 2x2,6 | 0,67 | G26H-600 | 2x2,6 | 0,70 | G40H-830 | 2x4,0 | 0,72 |
| 800 x 1700 | S10C-350 | 2x1,0 | 0,55 | S10C-450 | 2x1,0 | 0,66 | G26H-550 | 2x2,6 | 0,73 | G26H-600 | 2x2,6 | 0,76 | G40H-830 | 2x4,0 | 0,78 |
| 800 x 1800 | S10C-400 | 2x1,0 | 0,60 | G26H-550 | 2x2,6 | 0,71 | G26H-600 | 2x2,6 | 0,78 | G26H-750 | 2x2,6 | 0,81 | G40H-830 | 2x4,0 | 0,84 |
| 800 x 1900 | S10C-400 | 2x1,0 | 0,66 | G26H-550 | 2x2,6 | 0,78 | G26H-600 | 2x2,6 | 0,84 | G26H-750 | 2x2,6 | 0,87 | G40H-830 | 2x4,0 | 0,89 |
| 800 x 2000 | S10C-450 | 2x1,0 | 0,71 | G26H-550 | 2x2,6 | 0,83 | G26H-750 | 2x2,6 | 0,89 | G26H-750 | 2x2,6 | 0,92 | G40H-830 | 2x4,0 | 0,96 |
| 800 x 2100 | S10C-450 | 2x1,0 | 0,76 | G26H-600 | 2x2,6 | 0,89 | G26H-750 | 2x2,6 | 0,95 | G26H-750 | 2x2,6 | 0,99 | G40H-830 | 2x4,0 | 1,01 |
| 800 x 2200 | S10C-450 | 2x1,0 | 0,81 | G26H-600 | 2x2,6 | 0,94 | G26H-750 | 2x2,6 | 1,02 | G26H-750 | 2x2,6 | 1,05 | G40H-830 | 2x4,0 | 1,07 |
| 900 x 800 | S08B-200 | 2x0,8 | 0,23 | S08B-300 | 2x0,8 | 0,28 | S08B-300 | 2x0,8 | 0,32 | S10C-400 | 2x1,0 | 0,35 | S10C-450 | 2x1,0 | 0,36 |
| 900 x 900 | S08B-200 | 2x0,8 | 0,26 | S08B-300 | 2x0,8 | 0,33 | S08B-300 | 2x0,8 | 0,38 | S10C-400 | 2x1,0 | 0,40 | S10C-450 | 2x1,0 | 0,42 |
| 900 x 1000 | S08B-200 | 2x0,8 | 0,31 | S08B-300 | 2x0,8 | 0,38 | S10C-400 | 2x1,0 | 0,43 | S08B-300 | 2x0,8 | 0,45 | S10C-450 | 2x1,0 | 0,48 |
| 900 x 1100 | S08B-200 | 2x0,8 | 0,35 | S10C-350 | 2x1,0 | 0,43 | S10C-400 | 2x1,0 | 0,48 | S10C-350 | 2x1,0 | 0,51 | G26H-550 | 2x2,6 | 0,53 |
| 900 x 1200 | S08B-300 | 2x0,8 | 0,39 | S08B-300 | 2x0,8 | 0,47 | S10C-350 | 2x1,0 | 0,53 | S10C-400 | 2x1,0 | 0,56 | G26H-550 | 2x2,6 | 0,58 |
| 900 x 1300 | S08B-300 | 2x0,8 | 0,43 | S10C-350 | 2x1,0 | 0,53 | S10C-400 | 2x1,0 | 0,59 | S10C-450 | 2x1,0 | 0,62 | S10C-450 | 2x1,0 | 0,64 |
| 900 x 1400 | S08B-300 | 2x0,8 | 0,48 | S10C-350 | 2x1,0 | 0,58 | S10C-450 | 2x1,0 | 0,64 | S10C-450 | 2x1,0 | 0,68 | G26H-750 | 2x2,6 | 0,70 |
| 900 x 1500 | S08B-300 | 2x0,8 | 0,53 | S10C-400 | 2x1,0 | 0,64 | S10C-450 | 2x1,0 | 0,70 | G26H-550 | 2x2,6 | 0,74 | G26H-750 | 2x2,6 | 0,77 |
| 900 x 1600 | S10C-350 | 2x1,0 | 0,58 | S10C-450 | 2x1,0 | 0,70 | G26H-550 | 2x2,6 | 0,77 | G26H-600 | 2x2,6 | 0,80 | G40H-830 | 2x4,0 | 0,83 |
| 900 x 1700 | S10C-350 | 2x1,0 | 0,63 | S10C-450 | 2x1,0 | 0,75 | G26H-550 | 2x2,6 | 0,83 | G26H-600 | 2x2,6 | 0,86 | G40H-830 | 2x4,0 | 0,89 |
| 900 x 1800 | S10C-400 | 2x1,0 | 0,68 | G26H-550 | 2x2,6 | 0,81 | G26H-600 | 2x2,6 | 0,88 | G26H-750 | 2x2,6 | 0,92 | G40H-830 | 2x4,0 | 0,95 |
| 900 x 1900 | S10C-400 | 2x1,0 | 0,74 | G26H-550 | 2x2,6 | 0,87 | G26H-600 | 2x2,6 | 0,95 | G26H-750 | 2x2,6 | 0,99 | G40H-830 | 2x4,0 | 1,02 |
| 900 x 2000 | S10C-450 | 2x1,0 | 0,80 | G26H-550 | 2x2,6 | 0,94 | G26H-750 | 2x2,6 | 1,02 | G26H-750 | 2x2,6 | 1,06 | G40H-830 | 2x4,0 | 1,08 |

(*) It is possible to make intermediate dimensions of the smoke exhaust window between the values given in the table. The size of the active aerodynamic area for these dimensions is determined by linear interpolation.
 (**) Smoke exhaust windows are equipped with a set of two spindle actuators. Power consumption is given for a set of two actuators.

1.2.5.1. technical specification - types of smoke exhaust windows opening outwards by means of spindle actuators

| WINDOW SIZE* B' x H' | OPENING ANGLE 30° | | | OPENING ANGLE 45° | | | OPENING ANGLE 60° | | | OPENING ANGLE 75° | | | OPENING ANGLE 90° | | |
|-------------------------|-------------------|--------------------------|-----------------------------------|-------------------|--------------------------|-----------------------------------|-------------------|--------------------------|-----------------------------------|-------------------|--------------------------|-----------------------------------|-------------------|--------------------------|-----------------------------------|
| | ACTUATOR | POWER CON-SUMPTION** [A] | ACTIVE AERODYNAMIC AREA [Aa] [m²] | ACTUATOR | POWER CON-SUMPTION** [A] | ACTIVE AERODYNAMIC AREA [Aa] [m²] | ACTUATOR | POWER CON-SUMPTION** [A] | ACTIVE AERODYNAMIC AREA [Aa] [m²] | ACTUATOR | POWER CON-SUMPTION** [A] | ACTIVE AERODYNAMIC AREA [Aa] [m²] | ACTUATOR | POWER CON-SUMPTION** [A] | ACTIVE AERODYNAMIC AREA [Aa] [m²] |
| 900 x 2100 | S10C-450 | 2x 1,0 | 0,85 | G26H-600 | 2x 2,6 | 1,00 | G26H-750 | 2x 2,6 | 1,09 | G26H-750 | 2x 2,6 | 1,13 | G40H-830 | 2x 4,0 | 1,15 |
| 900 x 2200 | S10C-450 | 2x 1,0 | 0,91 | G26H-600 | 2x 2,6 | 1,07 | G26H-750 | 2x 2,6 | 1,16 | G26H-750 | 2x 2,6 | 1,19 | G40H-830 | 2x 4,0 | 1,23 |
| 1000 x 800 | S08B-200 | 2x 0,8 | 0,25 | S08B-300 | 2x 0,8 | 0,32 | S08B-300 | 2x 0,8 | 0,37 | S08B-300 | 2x 0,8 | 0,39 | S10C-450 | 2x 1,0 | 0,41 |
| 1000 x 900 | S08B-200 | 2x 0,8 | 0,29 | S08B-300 | 2x 0,8 | 0,37 | S08B-300 | 2x 0,8 | 0,43 | S10C-400 | 2x 1,0 | 0,45 | S10C-450 | 2x 1,0 | 0,47 |
| 1000 x 1000 | S08B-200 | 2x 0,8 | 0,34 | S08B-300 | 2x 0,8 | 0,42 | S10C-400 | 2x 1,0 | 0,48 | S08B-300 | 2x 0,8 | 0,51 | S10C-450 | 2x 1,0 | 0,54 |
| 1000 x 1100 | S08B-200 | 2x 0,8 | 0,38 | S10C-350 | 2x 1,0 | 0,48 | S10C-400 | 2x 1,0 | 0,54 | S10C-350 | 2x 1,0 | 0,57 | G26H-550 | 2x 2,6 | 0,59 |
| 1000 x 1200 | S08B-300 | 2x 0,8 | 0,43 | S08B-300 | 2x 0,8 | 0,53 | S10C-350 | 2x 1,0 | 0,60 | S10C-400 | 2x 1,0 | 0,63 | G26H-550 | 2x 2,6 | 0,66 |
| 1000 x 1300 | S08B-300 | 2x 0,8 | 0,48 | S10C-350 | 2x 1,0 | 0,59 | S10C-400 | 2x 1,0 | 0,66 | S10C-450 | 2x 1,0 | 0,70 | S10C-450 | 2x 1,0 | 0,72 |
| 1000 x 1400 | S08B-300 | 2x 0,8 | 0,53 | S10C-350 | 2x 1,0 | 0,65 | S10C-450 | 2x 1,0 | 0,72 | S10C-450 | 2x 1,0 | 0,76 | G26H-750 | 2x 2,6 | 0,79 |
| 1000 x 1500 | S08B-300 | 2x 0,8 | 0,58 | S10C-400 | 2x 1,0 | 0,71 | S10C-450 | 2x 1,0 | 0,79 | G26H-550 | 2x 2,6 | 0,83 | G26H-750 | 2x 2,6 | 0,86 |
| 1000 x 1600 | S10C-350 | 2x 1,0 | 0,64 | S10C-450 | 2x 1,0 | 0,77 | G26H-550 | 2x 2,6 | 0,86 | G26H-600 | 2x 2,6 | 0,90 | G40H-830 | 2x 4,0 | 0,93 |
| 1000 x 1700 | S10C-350 | 2x 1,0 | 0,70 | S10C-450 | 2x 1,0 | 0,84 | G26H-550 | 2x 2,6 | 0,92 | G26H-600 | 2x 2,6 | 0,97 | G40H-830 | 2x 4,0 | 0,99 |
| 1000 x 1800 | S10C-400 | 2x 1,0 | 0,76 | G26H-550 | 2x 2,6 | 0,91 | G26H-600 | 2x 2,6 | 1,00 | G26H-750 | 2x 2,6 | 1,04 | G40H-830 | 2x 4,0 | 1,07 |
| 1000 x 1900 | S10C-400 | 2x 1,0 | 0,82 | G26H-550 | 2x 2,6 | 0,98 | G26H-600 | 2x 2,6 | 1,07 | G26H-750 | 2x 2,6 | 1,11 | G40H-830 | 2x 4,0 | 1,14 |
| 1000 x 2000 | S10C-450 | 2x 1,0 | 0,88 | G26H-550 | 2x 2,6 | 1,05 | G26H-750 | 2x 2,6 | 1,15 | G26H-750 | 2x 2,6 | 1,18 | G40H-830 | 2x 4,0 | 1,22 |
| 1000 x 2100 | S10C-450 | 2x 1,0 | 0,96 | G26H-600 | 2x 2,6 | 1,13 | G26H-750 | 2x 2,6 | 1,21 | G26H-750 | 2x 2,6 | 1,25 | G40H-830 | 2x 4,0 | 1,30 |
| 1000 x 2200 | S10C-450 | 2x 1,0 | 1,03 | G26H-600 | 2x 2,6 | 1,20 | G26H-750 | 2x 2,6 | 1,29 | G26H-750 | 2x 2,6 | 1,34 | G40H-830 | 2x 4,0 | 1,37 |
| 1100 x 800 | S08B-200 | 2x 0,8 | 0,28 | S08B-300 | 2x 0,8 | 0,36 | S08B-300 | 2x 0,8 | 0,41 | S10C-400 | 2x 1,0 | 0,43 | S10C-450 | 2x 1,0 | 0,46 |
| 1100 x 900 | S08B-200 | 2x 0,8 | 0,32 | S08B-300 | 2x 0,8 | 0,41 | S08B-300 | 2x 0,8 | 0,47 | S10C-400 | 2x 1,0 | 0,50 | S10C-450 | 2x 1,0 | 0,52 |
| 1100 x 1000 | S08B-200 | 2x 0,8 | 0,37 | S08B-300 | 2x 0,8 | 0,46 | S10C-400 | 2x 1,0 | 0,53 | S08B-300 | 2x 0,8 | 0,56 | S10C-450 | 2x 1,0 | 0,59 |
| 1100 x 1100 | S08B-200 | 2x 0,8 | 0,42 | S10C-350 | 2x 1,0 | 0,52 | S10C-400 | 2x 1,0 | 0,60 | S10C-350 | 2x 1,0 | 0,63 | G26H-550 | 2x 2,6 | 0,66 |
| 1100 x 1200 | S08B-300 | 2x 0,8 | 0,48 | S08B-300 | 2x 0,8 | 0,59 | S10C-350 | 2x 1,0 | 0,66 | S10C-400 | 2x 1,0 | 0,70 | G26H-550 | 2x 2,6 | 0,73 |
| 1100 x 1300 | S08B-300 | 2x 0,8 | 0,53 | S10C-350 | 2x 1,0 | 0,65 | S10C-400 | 2x 1,0 | 0,73 | S10C-450 | 2x 1,0 | 0,78 | G26H-600 | 2x 2,6 | 0,80 |
| 1100 x 1400 | S08B-300 | 2x 0,8 | 0,59 | S10C-350 | 2x 1,0 | 0,72 | S10C-450 | 2x 1,0 | 0,81 | S10C-450 | 2x 1,0 | 0,84 | G26H-750 | 2x 2,6 | 0,88 |
| 1100 x 1500 | S08B-300 | 2x 0,8 | 0,65 | S10C-400 | 2x 1,0 | 0,79 | S10C-450 | 2x 1,0 | 0,88 | G26H-550 | 2x 2,6 | 0,92 | G26H-750 | 2x 2,6 | 0,95 |
| 1100 x 1600 | S10C-350 | 2x 1,0 | 0,71 | S10C-450 | 2x 1,0 | 0,86 | G26H-550 | 2x 2,6 | 0,95 | G26H-600 | 2x 2,6 | 0,99 | G40H-830 | 2x 4,0 | 1,04 |
| 1100 x 1700 | S10C-350 | 2x 1,0 | 0,77 | S10C-450 | 2x 1,0 | 0,93 | G26H-550 | 2x 2,6 | 1,03 | G26H-600 | 2x 2,6 | 1,07 | G40H-830 | 2x 4,0 | 1,11 |
| 1100 x 1800 | S10C-400 | 2x 1,0 | 0,84 | G26H-550 | 2x 2,6 | 1,00 | G26H-600 | 2x 2,6 | 1,11 | G26H-750 | 2x 2,6 | 1,15 | G40H-830 | 2x 4,0 | 1,19 |

(*) It is possible to make intermediate dimensions of the smoke exhaust window between the values given in the table. The size of the active aerodynamic area for these dimensions is determined by linear interpolation.
 (***) Smoke exhaust windows are equipped with a set of two spindle actuators. Power consumption is given for a set of two actuators.

1.2.5.1. technical specification - types of smoke exhaust windows opening outwards by means of spindle actuators

| WINDOW SIZE* B' x H' | OPENING ANGLE 30° | | | OPENING ANGLE 45° | | | OPENING ANGLE 60° | | | OPENING ANGLE 75° | | | OPENING ANGLE 90° | | |
|-------------------------|-------------------|--------------------------|-----------------------------------|-------------------|--------------------------|-----------------------------------|-------------------|--------------------------|-----------------------------------|-------------------|--------------------------|-----------------------------------|-------------------|--------------------------|-----------------------------------|
| | ACTUATOR | POWER CON-SUMPTION** [A] | ACTIVE AERODYNAMIC AREA [Aa] [m²] | ACTUATOR | POWER CON-SUMPTION** [A] | ACTIVE AERODYNAMIC AREA [Aa] [m²] | ACTUATOR | POWER CON-SUMPTION** [A] | ACTIVE AERODYNAMIC AREA [Aa] [m²] | ACTUATOR | POWER CON-SUMPTION** [A] | ACTIVE AERODYNAMIC AREA [Aa] [m²] | ACTUATOR | POWER CON-SUMPTION** [A] | ACTIVE AERODYNAMIC AREA [Aa] [m²] |
| 1100 x 1900 | S10C-400 | 2x 1,0 | 0,91 | G26H-550 | 2x 2,6 | 1,08 | G26H-600 | 2x 2,6 | 1,17 | G26H-750 | 2x 2,6 | 1,23 | G40H-830 | 2x 4,0 | 1,26 |
| 1100 x 2000 | S10C-450 | 2x 1,0 | 0,98 | G26H-550 | 2x 2,6 | 1,16 | G26H-750 | 2x 2,6 | 1,26 | G26H-750 | 2x 2,6 | 1,31 | G40H-830 | 2x 4,0 | 1,35 |
| 1100 x 2100 | S10C-450 | 2x 1,0 | 1,05 | G26H-600 | 2x 2,6 | 1,24 | G26H-750 | 2x 2,6 | 1,35 | G26H-750 | 2x 2,6 | 1,40 | G40H-830 | 2x 4,0 | 1,43 |
| 1100 x 2200 | S10C-450 | 2x 1,0 | 1,12 | G26H-600 | 2x 2,6 | 1,32 | G26H-750 | 2x 2,6 | 1,44 | G26H-750 | 2x 2,6 | 1,48 | G40H-830 | 2x 4,0 | 1,52 |
| 1200 x 800 | S08B-200 | 2x 0,8 | 0,30 | S08B-300 | 2x 0,8 | 0,39 | S08B-300 | 2x 0,8 | 0,45 | S10C-400 | 2x 1,0 | 0,48 | S10C-450 | 2x 1,0 | 0,50 |
| 1200 x 900 | S08B-200 | 2x 0,8 | 0,35 | S08B-300 | 2x 0,8 | 0,44 | S08B-300 | 2x 0,8 | 0,51 | S10C-400 | 2x 1,0 | 0,54 | S10C-450 | 2x 1,0 | 0,57 |
| 1200 x 1000 | S08B-200 | 2x 0,8 | 0,41 | S08B-300 | 2x 0,8 | 0,51 | S10C-400 | 2x 1,0 | 0,58 | S08B-300 | 2x 0,8 | 0,62 | S10C-450 | 2x 1,0 | 0,64 |
| 1200 x 1100 | S08B-200 | 2x 0,8 | 0,46 | S10C-350 | 2x 1,0 | 0,58 | S10C-400 | 2x 1,0 | 0,66 | S10C-350 | 2x 1,0 | 0,69 | G26H-550 | 2x 2,6 | 0,72 |
| 1200 x 1200 | S08B-300 | 2x 0,8 | 0,51 | S08B-300 | 2x 0,8 | 0,64 | S10C-350 | 2x 1,0 | 0,73 | S10C-400 | 2x 1,0 | 0,77 | G26H-550 | 2x 2,6 | 0,80 |
| 1200 x 1300 | S08B-300 | 2x 0,8 | 0,57 | S10C-350 | 2x 1,0 | 0,72 | S10C-400 | 2x 1,0 | 0,81 | S10C-450 | 2x 1,0 | 0,85 | G26H-600 | 2x 2,6 | 0,88 |
| 1200 x 1400 | S08B-300 | 2x 0,8 | 0,63 | S10C-350 | 2x 1,0 | 0,79 | S10C-450 | 2x 1,0 | 0,89 | G26G-450 | 2x 2,6 | 0,93 | G26H-750 | 2x 2,6 | 0,96 |
| 1200 x 1500 | S08B-300 | 2x 0,8 | 0,70 | S10C-400 | 2x 1,0 | 0,87 | S10C-450 | 2x 1,0 | 0,96 | G26H-550 | 2x 2,6 | 1,01 | G26H-750 | 2x 2,6 | 1,05 |
| 1200 x 1600 | S10C-350 | 2x 1,0 | 0,77 | S10C-450 | 2x 1,0 | 0,94 | G26H-550 | 2x 2,6 | 1,04 | G26H-600 | 2x 2,6 | 1,09 | G40H-830 | 2x 4,0 | 1,12 |
| 1200 x 1700 | S10C-350 | 2x 1,0 | 0,84 | S10C-450 | 2x 1,0 | 1,01 | G26H-550 | 2x 2,6 | 1,13 | G26H-600 | 2x 2,6 | 1,17 | G40H-830 | 2x 4,0 | 1,22 |
| 1200 x 1800 | S10C-400 | 2x 1,0 | 0,91 | G26H-550 | 2x 2,6 | 1,09 | G26H-600 | 2x 2,6 | 1,20 | G26H-750 | 2x 2,6 | 1,26 | G40H-830 | 2x 4,0 | 1,30 |
| 1200 x 1900 | S10C-400 | 2x 1,0 | 0,98 | G26H-550 | 2x 2,6 | 1,18 | G26H-600 | 2x 2,6 | 1,29 | G26H-750 | 2x 2,6 | 1,35 | G40H-830 | 2x 4,0 | 1,39 |
| 1200 x 2000 | S10C-450 | 2x 1,0 | 1,06 | G26H-550 | 2x 2,6 | 1,26 | G26H-750 | 2x 2,6 | 1,39 | G26H-750 | 2x 2,6 | 1,44 | G40H-830 | 2x 4,0 | 1,49 |
| 1200 x 2100 | S10C-450 | 2x 1,0 | 1,13 | G26H-600 | 2x 2,6 | 1,36 | G26H-750 | 2x 2,6 | 1,48 | G26H-750 | 2x 2,6 | 1,53 | G40H-830 | 2x 4,0 | 1,57 |
| 1200 x 2200 | S10C-450 | 2x 1,0 | 1,23 | G26H-600 | 2x 2,6 | 1,45 | G26H-750 | 2x 2,6 | 1,55 | G26H-750 | 2x 2,6 | 1,61 | G40H-830 | 2x 4,0 | 1,66 |
| 1300 x 800 | S08B-200 | 2x 0,8 | 0,33 | S08B-300 | 2x 0,8 | 0,41 | S08B-300 | 2x 0,8 | 0,48 | S10C-400 | 2x 1,0 | 0,52 | S10C-450 | 2x 1,0 | 0,54 |
| 1300 x 900 | S08B-200 | 2x 0,8 | 0,39 | S08B-300 | 2x 0,8 | 0,48 | S08B-300 | 2x 0,8 | 0,55 | S10C-400 | 2x 1,0 | 0,59 | S10C-450 | 2x 1,0 | 0,62 |
| 1300 x 1000 | S08B-200 | 2x 0,8 | 0,43 | S08B-300 | 2x 0,8 | 0,56 | S10C-400 | 2x 1,0 | 0,64 | S08B-300 | 2x 0,8 | 0,68 | S10C-450 | 2x 1,0 | 0,70 |
| 1300 x 1100 | S08B-200 | 2x 0,8 | 0,50 | S10C-350 | 2x 1,0 | 0,63 | S10C-400 | 2x 1,0 | 0,71 | S10C-350 | 2x 1,0 | 0,76 | G26H-550 | 2x 2,6 | 0,79 |
| 1300 x 1200 | S08B-300 | 2x 0,8 | 0,56 | S08B-300 | 2x 0,8 | 0,70 | S10C-350 | 2x 1,0 | 0,79 | S10C-400 | 2x 1,0 | 0,85 | G26H-550 | 2x 2,6 | 0,87 |
| 1300 x 1300 | S08B-300 | 2x 0,8 | 0,62 | S10C-350 | 2x 1,0 | 0,77 | S10C-400 | 2x 1,0 | 0,88 | S10C-450 | 2x 1,0 | 0,92 | G26H-600 | 2x 2,6 | 0,97 |
| 1300 x 1400 | S08B-300 | 2x 0,8 | 0,69 | S10C-350 | 2x 1,0 | 0,85 | S10C-450 | 2x 1,0 | 0,95 | G26G-450 | 2x 2,6 | 1,02 | G26H-750 | 2x 2,6 | 1,05 |
| 1300 x 1500 | S08B-300 | 2x 0,8 | 0,76 | S10C-400 | 2x 1,0 | 0,93 | S10C-450 | 2x 1,0 | 1,05 | G26H-550 | 2x 2,6 | 1,10 | G26H-750 | 2x 2,6 | 1,15 |
| 1300 x 1600 | S10C-350 | 2x 1,0 | 0,84 | S10C-450 | 2x 1,0 | 1,01 | G26H-550 | 2x 2,6 | 1,14 | G26H-600 | 2x 2,6 | 1,19 | G40H-830 | 2x 4,0 | 1,23 |

(*) It is possible to make intermediate dimensions of the smoke exhaust window between the values given in the table. The size of the active aerodynamic area for these dimensions is determined by linear interpolation.
 (**) Smoke exhaust windows are equipped with a set of two spindle actuators. Power consumption is given for a set of two actuators.

1.2.5.1. technical specification - types of smoke exhaust windows opening outwards by means of spindle actuators

| WINDOW SIZE* B' x H' [mm] | OPENING ANGLE 30° | | | OPENING ANGLE 45° | | | OPENING ANGLE 60° | | | OPENING ANGLE 75° | | | OPENING ANGLE 90° | | |
|---------------------------------|-------------------|--------------------------|-----------------------------------|-------------------|--------------------------|-----------------------------------|-------------------|--------------------------|-----------------------------------|-------------------|--------------------------|-----------------------------------|-------------------|--------------------------|-----------------------------------|
| | ACTUATOR | POWER CON-SUMPTION** [A] | ACTIVE AERODYNAMIC AREA [Aa] [m²] | ACTUATOR | POWER CON-SUMPTION** [A] | ACTIVE AERODYNAMIC AREA [Aa] [m²] | ACTUATOR | POWER CON-SUMPTION** [A] | ACTIVE AERODYNAMIC AREA [Aa] [m²] | ACTUATOR | POWER CON-SUMPTION** [A] | ACTIVE AERODYNAMIC AREA [Aa] [m²] | ACTUATOR | POWER CON-SUMPTION** [A] | ACTIVE AERODYNAMIC AREA [Aa] [m²] |
| 1300 x 1700 | S10C-350 | 2x 1,0 | 0,91 | S10C-450 | 2x 1,0 | 1,10 | G26H-550 | 2x 2,6 | 1,22 | G26H-600 | 2x 2,6 | 1,28 | G40H-830 | 2x 4,0 | 1,33 |
| 1300 x 1800 | S10C-400 | 2x 1,0 | 0,99 | G26H-550 | 2x 2,6 | 1,19 | G26H-600 | 2x 2,6 | 1,31 | G26H-750 | 2x 2,6 | 1,37 | G40H-830 | 2x 4,0 | 1,41 |
| 1300 x 1900 | S10C-400 | 2x 1,0 | 1,07 | G26H-550 | 2x 2,6 | 1,28 | G26H-600 | 2x 2,6 | 1,41 | G26H-750 | 2x 2,6 | 1,47 | G40H-830 | 2x 4,0 | 1,52 |
| 1300 x 2000 | S10C-450 | 2x 1,0 | 1,15 | G26H-550 | 2x 2,6 | 1,37 | G26H-750 | 2x 2,6 | 1,51 | G26H-750 | 2x 2,6 | 1,56 | G40H-830 | 2x 4,0 | 1,60 |
| 1300 x 2100 | S10C-450 | 2x 1,0 | 1,23 | G26H-600 | 2x 2,6 | 1,46 | G26H-750 | 2x 2,6 | 1,59 | G26H-750 | 2x 2,6 | 1,65 | G40H-830 | 2x 4,0 | 1,71 |
| 1300 x 2200 | S10C-450 | 2x 1,0 | 1,32 | G26H-600 | 2x 2,6 | 1,56 | G26H-750 | 2x 2,6 | 1,69 | G26H-750 | 2x 2,6 | 1,76 | G40H-830 | 2x 4,0 | 1,79 |
| 1400 x 800 | S08B-200 | 2x 0,8 | 0,36 | S08B-300 | 2x 0,8 | 0,45 | S08B-300 | 2x 0,8 | 0,53 | S10C-400 | 2x 1,0 | 0,56 | S10C-450 | 2x 1,0 | 0,58 |
| 1400 x 900 | S08B-200 | 2x 0,8 | 0,41 | S08B-300 | 2x 0,8 | 0,53 | S08B-300 | 2x 0,8 | 0,60 | S10C-400 | 2x 1,0 | 0,64 | S10C-450 | 2x 1,0 | 0,67 |
| 1400 x 1000 | S08B-200 | 2x 0,8 | 0,47 | S08B-300 | 2x 0,8 | 0,60 | S10C-400 | 2x 1,0 | 0,69 | G26G-450 | 2x 2,6 | 0,73 | S10C-450 | 2x 1,0 | 0,76 |
| 1400 x 1100 | S08B-200 | 2x 0,8 | 0,54 | S10C-350 | 2x 1,0 | 0,67 | S10C-400 | 2x 1,0 | 0,77 | G26G-450 | 2x 2,6 | 0,82 | G26H-550 | 2x 2,6 | 0,86 |
| 1400 x 1200 | S08B-300 | 2x 0,8 | 0,61 | S08B-300 | 2x 0,8 | 0,75 | S10C-350 | 2x 1,0 | 0,86 | G26H-550 | 2x 2,6 | 0,91 | G26H-550 | 2x 2,6 | 0,94 |
| 1400 x 1300 | S08B-300 | 2x 0,8 | 0,68 | S10C-350 | 2x 1,0 | 0,84 | S10C-400 | 2x 1,0 | 0,94 | G26H-550 | 2x 2,6 | 1,00 | G26H-600 | 2x 2,6 | 1,05 |
| 1400 x 1400 | S08B-300 | 2x 0,8 | 0,75 | S10C-350 | 2x 1,0 | 0,92 | S10C-450 | 2x 1,0 | 1,04 | G26G-450 | 2x 2,6 | 1,10 | G26H-750 | 2x 2,6 | 1,14 |
| 1400 x 1500 | S08B-300 | 2x 0,8 | 0,83 | S10C-400 | 2x 1,0 | 1,01 | S10C-450 | 2x 1,0 | 1,13 | G26H-550 | 2x 2,6 | 1,19 | G26H-750 | 2x 2,6 | 1,22 |
| 1400 x 1600 | S10C-350 | 2x 1,0 | 0,91 | S10C-450 | 2x 1,0 | 1,10 | G26H-550 | 2x 2,6 | 1,22 | G26H-600 | 2x 2,6 | 1,29 | G40H-830 | 2x 4,0 | 1,33 |
| 1400 x 1700 | S10C-350 | 2x 1,0 | 0,99 | S10C-450 | 2x 1,0 | 1,19 | G26H-550 | 2x 2,6 | 1,32 | G26H-600 | 2x 2,6 | 1,38 | G40H-830 | 2x 4,0 | 1,42 |
| 1400 x 1800 | S10C-400 | 2x 1,0 | 1,05 | G26H-550 | 2x 2,6 | 1,28 | G26H-600 | 2x 2,6 | 1,42 | G26H-750 | 2x 2,6 | 1,49 | G40H-830 | 2x 4,0 | 1,53 |
| 1400 x 1900 | S10C-400 | 2x 1,0 | 1,14 | G26H-550 | 2x 2,6 | 1,38 | G26H-600 | 2x 2,6 | 1,53 | G26H-750 | 2x 2,6 | 1,59 | G40H-830 | 2x 4,0 | 1,65 |
| 1400 x 2000 | S10C-450 | 2x 1,0 | 1,24 | G26H-550 | 2x 2,6 | 1,48 | G26H-750 | 2x 2,6 | 1,61 | G26H-750 | 2x 2,6 | 1,68 | G40H-830 | 2x 4,0 | 1,73 |
| 1400 x 2100 | S10C-450 | 2x 1,0 | 1,34 | G26H-600 | 2x 2,6 | 1,58 | G26H-750 | 2x 2,6 | 1,72 | G26H-750 | 2x 2,6 | 1,79 | G40H-830 | 2x 4,0 | 1,85 |
| 1400 x 2200 | S10C-450 | 2x 1,0 | 1,43 | G26H-600 | 2x 2,6 | 1,69 | G26H-750 | 2x 2,6 | 1,84 | G26H-750 | 2x 2,6 | 1,90 | G40H-830 | 2x 4,0 | 1,94 |
| 1500 x 800 | S08B-200 | 2x 0,8 | 0,38 | S08B-300 | 2x 0,8 | 0,48 | S08B-300 | 2x 0,8 | 0,57 | S10C-400 | 2x 1,0 | 0,60 | S10C-450 | 2x 1,0 | 0,62 |
| 1500 x 900 | S08B-200 | 2x 0,8 | 0,44 | S08B-300 | 2x 0,8 | 0,57 | S08B-300 | 2x 0,8 | 0,65 | S10C-400 | 2x 1,0 | 0,69 | S10C-450 | 2x 1,0 | 0,73 |
| 1500 x 1000 | S08B-200 | 2x 0,8 | 0,51 | S08B-300 | 2x 0,8 | 0,64 | S10C-400 | 2x 1,0 | 0,74 | G26G-450 | 2x 2,6 | 0,79 | G26H-550 | 2x 2,6 | 0,82 |
| 1500 x 1100 | S08B-200 | 2x 0,8 | 0,58 | S10C-350 | 2x 1,0 | 0,72 | S10C-400 | 2x 1,0 | 0,83 | G26G-450 | 2x 2,6 | 0,88 | G26H-550 | 2x 2,6 | 0,92 |
| 1500 x 1200 | S08B-300 | 2x 0,8 | 0,65 | S08B-300 | 2x 0,8 | 0,81 | S10C-350 | 2x 1,0 | 0,93 | G26H-550 | 2x 2,6 | 0,97 | G26H-550 | 2x 2,6 | 1,02 |
| 1500 x 1300 | S08B-300 | 2x 0,8 | 0,73 | S10C-350 | 2x 1,0 | 0,90 | S10C-400 | 2x 1,0 | 1,01 | G26H-550 | 2x 2,6 | 1,08 | G26H-600 | 2x 2,6 | 1,11 |
| 1500 x 1400 | S08B-300 | 2x 0,8 | 0,79 | S10C-350 | 2x 1,0 | 0,99 | S10C-450 | 2x 1,0 | 1,12 | G26G-450 | 2x 2,6 | 1,17 | G26H-750 | 2x 2,6 | 1,22 |

(*) It is possible to make intermediate dimensions of the smoke exhaust window between the values given in the table. The size of the active aerodynamic area for these dimensions is determined by linear interpolation.
 (**) Smoke exhaust windows are equipped with a set of two spindle actuators. Power consumption is given for a set of two actuators.

1.2.5.1. technical specification - types of smoke exhaust windows opening outwards by means of spindle actuators

| WINDOW SIZE* B' x H' | OPENING ANGLE 30° | | | OPENING ANGLE 45° | | | OPENING ANGLE 60° | | | OPENING ANGLE 75° | | | OPENING ANGLE 90° | | |
|-------------------------|-------------------|--------------------------|-----------------------------------|-------------------|--------------------------|-----------------------------------|-------------------|--------------------------|-----------------------------------|-------------------|--------------------------|-----------------------------------|-------------------|--------------------------|-----------------------------------|
| | ACTUATOR | POWER CON-SUMPTION** [A] | ACTIVE AERODYNAMIC AREA [Aa] [m²] | ACTUATOR | POWER CON-SUMPTION** [A] | ACTIVE AERODYNAMIC AREA [Aa] [m²] | ACTUATOR | POWER CON-SUMPTION** [A] | ACTIVE AERODYNAMIC AREA [Aa] [m²] | ACTUATOR | POWER CON-SUMPTION** [A] | ACTIVE AERODYNAMIC AREA [Aa] [m²] | ACTUATOR | POWER CON-SUMPTION** [A] | ACTIVE AERODYNAMIC AREA [Aa] [m²] |
| 1500 x 1500 | S08B-300 | 2x 0,8 | 0,87 | S10C-400 | 2x 1,0 | 1,09 | S10C-450 | 2x 1,0 | 1,22 | G26H-550 | 2x 2,6 | 1,28 | G26H-750 | 2x 2,6 | 1,32 |
| 1500 x 1600 | S10C-350 | 2x 1,0 | 0,96 | S10C-450 | 2x 1,0 | 1,18 | G26H-550 | 2x 2,6 | 1,31 | G26H-600 | 2x 2,6 | 1,38 | G40H-830 | 2x 4,0 | 1,44 |
| 1500 x 1700 | S10C-350 | 2x 1,0 | 1,04 | S10C-450 | 2x 2,6 | 1,27 | G26H-550 | 2x 2,6 | 1,42 | G26H-600 | 2x 2,6 | 1,49 | G40H-830 | 2x 4,0 | 1,53 |
| 1500 x 1800 | S10C-400 | 2x 1,0 | 1,13 | G26H-550 | 2x 2,6 | 1,37 | G26H-600 | 2x 2,6 | 1,53 | G26H-750 | 2x 2,6 | 1,59 | G40H-830 | 2x 4,0 | 1,65 |
| 1500 x 1900 | S10C-400 | 2x 1,0 | 1,22 | G26H-550 | 2x 2,6 | 1,47 | G26H-600 | 2x 2,6 | 1,62 | G26H-750 | 2x 2,6 | 1,69 | G40H-830 | 2x 4,0 | 1,74 |
| 1500 x 2000 | S10C-450 | 2x 1,0 | 1,32 | G26H-550 | 2x 2,6 | 1,58 | G26H-750 | 2x 2,6 | 1,74 | G26H-750 | 2x 2,6 | 1,80 | G40H-830 | 2x 4,0 | 1,87 |
| 1500 x 2100 | S10C-450 | 2x 1,0 | 1,41 | G26H-600 | 2x 2,6 | 1,69 | G26H-750 | 2x 2,6 | 1,86 | G26H-750 | 2x 2,6 | 1,93 | G40H-830 | 2x 4,0 | 1,97 |
| 1500 x 2200 | S10C-450 | 2x 1,0 | 1,51 | G26H-600 | 2x 2,6 | 1,79 | G26H-750 | 2x 2,6 | 1,95 | G26H-750 | 2x 2,6 | 2,04 | G40H-830 | 2x 4,0 | 2,10 |
| 1600 x 800 | S08B-200 | 2x 0,8 | 0,40 | S08B-300 | 2x 0,8 | 0,52 | S08B-300 | 2x 0,8 | 0,60 | S10C-400 | 2x 1,0 | 0,64 | S10C-450 | 2x 1,0 | 0,67 |
| 1600 x 900 | S08B-200 | 2x 0,8 | 0,47 | S08B-300 | 2x 0,8 | 0,61 | S08B-300 | 2x 0,8 | 0,70 | S10C-400 | 2x 1,0 | 0,74 | S10C-450 | 2x 1,0 | 0,78 |
| 1600 x 1000 | S08B-200 | 2x 0,8 | 0,55 | S08B-300 | 2x 0,8 | 0,68 | S10C-400 | 2x 1,0 | 0,78 | G26G-450 | 2x 2,6 | 0,84 | G26H-550 | 2x 2,6 | 0,88 |
| 1600 x 1100 | S08B-200 | 2x 0,8 | 0,62 | S10C-350 | 2x 1,0 | 0,78 | S10C-400 | 2x 1,0 | 0,89 | G26G-450 | 2x 2,6 | 0,95 | G26H-550 | 2x 2,6 | 0,98 |
| 1600 x 1200 | S08B-300 | 2x 0,8 | 0,68 | S08B-300 | 2x 0,8 | 0,87 | S10C-350 | 2x 1,0 | 0,99 | G26H-550 | 2x 2,6 | 1,04 | G26H-550 | 2x 2,6 | 1,09 |
| 1600 x 1300 | S08B-300 | 2x 0,8 | 0,77 | S10C-350 | 2x 1,0 | 0,96 | S10C-400 | 2x 1,0 | 1,09 | G26H-550 | 2x 2,6 | 1,16 | G26H-600 | 2x 2,6 | 1,19 |
| 1600 x 1400 | S08B-300 | 2x 0,8 | 0,85 | S10C-350 | 2x 1,0 | 1,05 | S10C-450 | 2x 1,0 | 1,20 | G26G-450 | 2x 2,6 | 1,25 | G26H-750 | 2x 2,6 | 1,31 |
| 1600 x 1500 | S08B-300 | 2x 0,8 | 0,94 | S10C-400 | 2x 1,0 | 1,15 | S10C-450 | 2x 1,0 | 1,29 | G26H-550 | 2x 2,6 | 1,37 | G26H-750 | 2x 2,6 | 1,41 |
| 1600 x 1600 | S10C-350 | 2x 1,0 | 1,03 | S10C-450 | 2x 1,0 | 1,25 | G26H-550 | 2x 2,6 | 1,40 | G26H-600 | 2x 2,6 | 1,47 | G40H-830 | 2x 4,0 | 1,54 |
| 1600 x 1700 | S10C-350 | 2x 1,0 | 1,12 | S10C-450 | 2x 1,0 | 1,36 | G26H-550 | 2x 2,6 | 1,52 | G26H-600 | 2x 2,6 | 1,59 | G40H-830 | 2x 4,0 | 1,64 |
| 1600 x 1800 | S10C-400 | 2x 1,0 | 1,21 | G26H-550 | 2x 2,6 | 1,46 | G26H-600 | 2x 2,6 | 1,61 | G26H-750 | 2x 2,6 | 1,69 | G40H-830 | 2x 4,0 | 1,76 |
| 1600 x 1900 | S10C-400 | 2x 1,0 | 1,31 | G26H-550 | 2x 2,6 | 1,58 | G26H-600 | 2x 2,6 | 1,74 | G26H-750 | 2x 2,6 | 1,82 | G40H-830 | 2x 4,0 | 1,87 |
| 1600 x 2000 | S10C-450 | 2x 1,0 | 1,41 | G26H-550 | 2x 2,6 | 1,68 | G26H-750 | 2x 2,6 | 1,86 | G26H-750 | 2x 2,6 | 1,93 | G40H-830 | 2x 4,0 | 2,00 |
| 1600 x 2100 | S10C-450 | 2x 1,0 | 1,51 | G26H-600 | 2x 2,6 | 1,80 | G26H-750 | 2x 2,6 | 1,96 | G26H-750 | 2x 2,6 | 2,05 | G40H-830 | 2x 4,0 | 2,11 |
| 1600 x 2200 | S10C-450 | 2x 1,0 | 1,62 | G26H-600 | 2x 2,6 | 1,92 | G26H-750 | 2x 2,6 | 2,09 | G26H-750 | 2x 2,6 | 2,17 | G40H-830 | 2x 4,0 | 2,25 |
| 1700 x 800 | S08B-200 | 2x 0,8 | 0,43 | S08B-300 | 2x 0,8 | 0,56 | S08B-300 | 2x 0,8 | 0,64 | S10C-400 | 2x 1,0 | 0,69 | S10C-450 | 2x 1,0 | 0,72 |
| 1700 x 900 | S08B-200 | 2x 0,8 | 0,50 | S08B-300 | 2x 0,8 | 0,65 | S08B-300 | 2x 0,8 | 0,74 | S10C-400 | 2x 1,0 | 0,79 | S10C-450 | 2x 1,0 | 0,83 |
| 1700 x 1000 | S08B-200 | 2x 0,8 | 0,58 | S08B-300 | 2x 0,8 | 0,73 | S10C-400 | 2x 1,0 | 0,84 | G26G-450 | 2x 2,6 | 0,89 | G26H-550 | 2x 2,6 | 0,94 |
| 1700 x 1100 | S08B-200 | 2x 0,8 | 0,65 | S10C-350 | 2x 1,0 | 0,83 | S10C-400 | 2x 1,0 | 0,95 | G26G-450 | 2x 2,6 | 1,01 | G26H-550 | 2x 2,6 | 1,04 |
| 1700 x 1200 | S08B-300 | 2x 0,8 | 0,73 | S08B-300 | 2x 0,8 | 0,92 | S10C-350 | 2x 1,0 | 1,04 | G26H-550 | 2x 2,6 | 1,11 | G26H-550 | 2x 2,6 | 1,17 |

(*) It is possible to make intermediate dimensions of the smoke exhaust window between the values given in the table. The size of the active aerodynamic area for these dimensions is determined by linear interpolation.
 (***) Smoke exhaust windows are equipped with a set of two spindle actuators. Power consumption is given for a set of two actuators.

1.2.5.1. technical specification - types of smoke exhaust windows opening outwards by means of spindle actuators

| WINDOW SIZE* B' x H' [mm] | OPENING ANGLE 30° | | | OPENING ANGLE 45° | | | OPENING ANGLE 60° | | | OPENING ANGLE 75° | | | OPENING ANGLE 90° | | |
|---------------------------------|-------------------|--------------------------|-----------------------------------|-------------------|--------------------------|-----------------------------------|-------------------|--------------------------|-----------------------------------|-------------------|--------------------------|-----------------------------------|-------------------|--------------------------|-----------------------------------|
| | ACTUATOR | POWER CON-SUMPTION** [A] | ACTIVE AERODYNAMIC AREA [Aa] [m²] | ACTUATOR | POWER CON-SUMPTION** [A] | ACTIVE AERODYNAMIC AREA [Aa] [m²] | ACTUATOR | POWER CON-SUMPTION** [A] | ACTIVE AERODYNAMIC AREA [Aa] [m²] | ACTUATOR | POWER CON-SUMPTION** [A] | ACTIVE AERODYNAMIC AREA [Aa] [m²] | ACTUATOR | POWER CON-SUMPTION** [A] | ACTIVE AERODYNAMIC AREA [Aa] [m²] |
| 1700 x 1300 | S088-300 | 2x 0,8 | 0,82 | S10C-350 | 2x 1,0 | 1,02 | S10C-400 | 2x 1,0 | 1,16 | G26H-550 | 2x 2,6 | 1,24 | G26H-600 | 2x 2,6 | 1,27 |
| 1700 x 1400 | S088-300 | 2x 0,8 | 0,91 | S10C-350 | 2x 1,0 | 1,12 | S10C-450 | 2x 1,0 | 1,28 | G26G-450 | 2x 2,6 | 1,34 | G26H-750 | 2x 2,6 | 1,40 |
| 1700 x 1500 | S088-300 | 2x 0,8 | 1,00 | S10C-400 | 2x 1,0 | 1,22 | G26G-450 | 2x 2,6 | 1,38 | G26H-550 | 2x 2,6 | 1,47 | G26H-750 | 2x 2,6 | 1,51 |
| 1700 x 1600 | S10C-350 | 2x 1,0 | 1,09 | S10C-450 | 2x 1,0 | 1,33 | G26H-550 | 2x 2,6 | 1,50 | G26H-600 | 2x 2,6 | 1,57 | G40H-830 | 2x 4,0 | 1,62 |
| 1700 x 1700 | S10C-350 | 2x 1,0 | 1,19 | S10C-450 | 2x 1,0 | 1,44 | G26H-550 | 2x 2,6 | 1,59 | G26H-600 | 2x 2,6 | 1,70 | G40H-830 | 2x 4,0 | 1,75 |
| 1700 x 1800 | S10C-400 | 2x 1,0 | 1,26 | G26H-550 | 2x 2,6 | 1,56 | G26H-600 | 2x 2,6 | 1,72 | G26H-750 | 2x 2,6 | 1,80 | G40H-830 | 2x 4,0 | 1,86 |
| 1700 x 1900 | S10C-400 | 2x 1,0 | 1,37 | G26H-550 | 2x 2,6 | 1,67 | G26H-600 | 2x 2,6 | 1,85 | G26H-750 | 2x 2,6 | 1,94 | G40H-830 | 2x 4,0 | 2,00 |
| 1700 x 2000 | S10C-450 | 2x 1,0 | 1,47 | G26H-550 | 2x 2,6 | 1,78 | G26H-750 | 2x 2,6 | 1,96 | G26H-750 | 2x 2,6 | 2,05 | G40H-830 | 2x 4,0 | 2,11 |
| 1800 x 800 | S088-200 | 2x 0,8 | 0,46 | S088-300 | 2x 0,8 | 0,59 | S088-300 | 2x 0,8 | 0,68 | S10C-400 | 2x 1,0 | 0,73 | S10C-450 | 2x 1,0 | 0,76 |
| 1800 x 900 | S088-200 | 2x 0,8 | 0,54 | S088-300 | 2x 0,8 | 0,68 | S088-300 | 2x 0,8 | 0,79 | S10C-400 | 2x 1,0 | 0,84 | S10C-450 | 2x 1,0 | 0,88 |
| 1800 x 1000 | S088-200 | 2x 0,8 | 0,62 | S088-300 | 2x 0,8 | 0,78 | S10C-400 | 2x 1,0 | 0,89 | G26G-450 | 2x 2,6 | 0,95 | G26H-550 | 2x 2,6 | 1,00 |
| 1800 x 1100 | S088-200 | 2x 0,8 | 0,69 | S10C-350 | 2x 1,0 | 0,88 | S10C-400 | 2x 1,0 | 1,01 | G26G-450 | 2x 2,6 | 1,07 | G26H-550 | 2x 2,6 | 1,11 |
| 1800 x 1200 | S088-300 | 2x 0,8 | 0,78 | S088-300 | 2x 0,8 | 0,97 | S10C-350 | 2x 1,0 | 1,11 | G26H-550 | 2x 2,6 | 1,18 | G26H-550 | 2x 2,6 | 1,24 |
| 1800 x 1300 | S088-300 | 2x 0,8 | 0,87 | S10C-350 | 2x 1,0 | 1,08 | S10C-400 | 2x 1,0 | 1,23 | G26H-550 | 2x 2,6 | 1,30 | G26H-600 | 2x 2,6 | 1,35 |
| 1800 x 1400 | S088-300 | 2x 0,8 | 0,96 | S10C-350 | 2x 1,0 | 1,18 | S10C-450 | 2x 1,0 | 1,34 | G26G-450 | 2x 2,6 | 1,42 | G26H-750 | 2x 2,6 | 1,47 |
| 1800 x 1500 | S088-300 | 2x 0,8 | 1,04 | S10C-400 | 2x 1,0 | 1,30 | G26G-450 | 2x 2,6 | 1,46 | G26H-550 | 2x 2,6 | 1,53 | G26H-750 | 2x 2,6 | 1,60 |
| 1800 x 1600 | S10C-350 | 2x 1,0 | 1,13 | S10C-450 | 2x 1,0 | 1,41 | G26H-550 | 2x 2,6 | 1,59 | G26H-600 | 2x 2,6 | 1,66 | G40H-830 | 2x 4,0 | 1,71 |
| 1800 x 1700 | S10C-350 | 2x 1,0 | 1,24 | S10C-450 | 2x 1,0 | 1,52 | G26H-550 | 2x 2,6 | 1,69 | G26H-600 | 2x 2,6 | 1,79 | G40H-830 | 2x 4,0 | 1,86 |
| 1800 x 1800 | S10C-400 | 2x 1,0 | 1,34 | G26H-550 | 2x 2,6 | 1,63 | G26H-600 | 2x 2,6 | 1,83 | G26H-750 | 2x 2,6 | 1,92 | G40H-830 | 2x 4,0 | 1,97 |
| 1800 x 1900 | S10C-400 | 2x 1,0 | 1,45 | G26H-550 | 2x 2,6 | 1,76 | G26H-600 | 2x 2,6 | 1,94 | G26H-750 | 2x 2,6 | 2,05 | G40H-830 | 2x 4,0 | 2,12 |
| 1900 x 800 | S088-200 | 2x 0,8 | 0,48 | S088-300 | 2x 0,8 | 0,63 | S088-300 | 2x 0,8 | 0,72 | S10C-400 | 2x 1,0 | 0,78 | S10C-450 | 2x 1,0 | 0,81 |
| 1900 x 900 | S088-200 | 2x 0,8 | 0,57 | S088-300 | 2x 0,8 | 0,72 | S088-300 | 2x 0,8 | 0,84 | S10C-400 | 2x 1,0 | 0,89 | G26H-550 | 2x 2,6 | 0,92 |
| 1900 x 1000 | S088-200 | 2x 0,8 | 0,64 | S088-300 | 2x 0,8 | 0,82 | S10C-400 | 2x 1,0 | 0,94 | G26G-450 | 2x 2,6 | 1,01 | G26H-550 | 2x 2,6 | 1,06 |
| 1900 x 1100 | S088-200 | 2x 0,8 | 0,73 | S10C-350 | 2x 1,0 | 0,93 | S10C-400 | 2x 1,0 | 1,07 | G26G-450 | 2x 2,6 | 1,13 | G26H-550 | 2x 2,6 | 1,17 |
| 1900 x 1200 | S088-300 | 2x 0,8 | 0,82 | S088-300 | 2x 0,8 | 1,03 | S10C-350 | 2x 1,0 | 1,18 | G26H-550 | 2x 2,6 | 1,25 | G26H-550 | 2x 2,6 | 1,31 |
| 1900 x 1300 | S088-300 | 2x 0,8 | 0,92 | S10C-350 | 2x 1,0 | 1,14 | S10C-400 | 2x 1,0 | 1,31 | G26H-550 | 2x 2,6 | 1,37 | G26H-600 | 2x 2,6 | 1,43 |
| 1900 x 1400 | S088-300 | 2x 0,8 | 1,00 | S10C-350 | 2x 1,0 | 1,25 | S10C-450 | 2x 1,0 | 1,42 | G26G-450 | 2x 2,6 | 1,51 | G26H-750 | 2x 2,6 | 1,55 |
| 1900 x 1500 | S088-300 | 2x 0,8 | 1,10 | S10C-400 | 2x 1,0 | 1,37 | G26G-450 | 2x 2,6 | 1,54 | G26H-550 | 2x 2,6 | 1,62 | G26H-750 | 2x 2,6 | 1,69 |

(*) It is possible to make intermediate dimensions of the smoke exhaust window between the values given in the table. The size of the active aerodynamic area for these dimensions is determined by linear interpolation.

(**) Smoke exhaust windows are equipped with a set of two spindle actuators. Power consumption is given for a set of two actuators.

1.2.5.1. technical specification - types of smoke exhaust windows opening outwards by means of spindle actuators

| WINDOW SIZE* B' x H' | OPENING ANGLE 30° | | | OPENING ANGLE 45° | | | OPENING ANGLE 60° | | | OPENING ANGLE 75° | | | OPENING ANGLE 90° | | |
|-------------------------|-------------------|--------------------------|-----------------------------------|-------------------|--------------------------|-----------------------------------|-------------------|--------------------------|-----------------------------------|-------------------|--------------------------|-----------------------------------|-------------------|--------------------------|-----------------------------------|
| | ACTUATOR | POWER CON-SUMPTION** [A] | ACTIVE AERODYNAMIC AREA [Aa] [m²] | ACTUATOR | POWER CON-SUMPTION** [A] | ACTIVE AERODYNAMIC AREA [Aa] [m²] | ACTUATOR | POWER CON-SUMPTION** [A] | ACTIVE AERODYNAMIC AREA [Aa] [m²] | ACTUATOR | POWER CON-SUMPTION** [A] | ACTIVE AERODYNAMIC AREA [Aa] [m²] | ACTUATOR | POWER CON-SUMPTION** [A] | ACTIVE AERODYNAMIC AREA [Aa] [m²] |
| 1900 x 1600 | S10C-350 | 2x 1,0 | 1,20 | S10C-450 | 2x 1,0 | 1,48 | G26H-550 | 2x 2,6 | 1,66 | G26H-600 | 2x 2,6 | 1,76 | G40H-830 | 2x 4,0 | 1,82 |
| 1900 x 1700 | S10C-350 | 2x 1,0 | 1,31 | S10C-450 | 2x 1,0 | 1,60 | G26H-550 | 2x 2,6 | 1,80 | G26H-600 | 2x 2,6 | 1,88 | G40H-830 | 2x 4,0 | 1,97 |
| 1900 x 1800 | S10C-400 | 2x 1,0 | 1,42 | G26H-550 | 2x 2,6 | 1,73 | G26H-600 | 2x 2,6 | 1,94 | G26H-750 | 2x 2,6 | 2,03 | G40H-830 | 2x 4,0 | 2,09 |
| 2000 x 800 | S08B-200 | 2x 0,8 | 0,51 | S08B-300 | 2x 0,8 | 0,66 | S08B-300 | 2x 0,8 | 0,76 | S10C-400 | 2x 1,0 | 0,82 | S10C-450 | 2x 1,0 | 0,85 |
| 2000 x 900 | S08B-200 | 2x 0,8 | 0,60 | S08B-300 | 2x 0,8 | 0,76 | S08B-300 | 2x 0,8 | 0,89 | S10C-400 | 2x 1,0 | 0,94 | G26H-550 | 2x 2,6 | 0,98 |
| 2000 x 1000 | S08B-200 | 2x 0,8 | 0,68 | S08B-300 | 2x 0,8 | 0,87 | S10C-400 | 2x 1,0 | 1,00 | G26G-450 | 2x 2,6 | 1,06 | G26H-550 | 2x 2,6 | 1,12 |
| 2000 x 1100 | S08B-200 | 2x 0,8 | 0,77 | S10C-350 | 2x 1,0 | 0,97 | S10C-400 | 2x 1,0 | 1,11 | G26G-450 | 2x 2,6 | 1,19 | G26H-550 | 2x 2,6 | 1,24 |
| 2000 x 1200 | S08B-300 | 2x 0,8 | 0,87 | S08B-300 | 2x 0,8 | 1,09 | G26G-450 | 2x 2,6 | 1,24 | G26H-550 | 2x 2,6 | 1,32 | G26H-550 | 2x 2,6 | 1,37 |
| 2000 x 1300 | S08B-300 | 2x 0,8 | 0,95 | S10C-350 | 2x 1,0 | 1,21 | G26G-450 | 2x 2,6 | 1,38 | G26H-550 | 2x 2,6 | 1,45 | G26H-600 | 2x 2,6 | 1,51 |
| 2000 x 1400 | S08B-300 | 2x 0,8 | 1,05 | S10C-350 | 2x 1,0 | 1,32 | G26G-450 | 2x 2,6 | 1,49 | G26G-450 | 2x 2,6 | 1,59 | G26H-750 | 2x 2,6 | 1,63 |
| 2000 x 1500 | S08B-300 | 2x 0,8 | 1,16 | S10C-400 | 2x 1,0 | 1,43 | G26G-450 | 2x 2,6 | 1,63 | G26H-550 | 2x 2,6 | 1,71 | G26H-750 | 2x 2,6 | 1,79 |
| 2000 x 1600 | S10C-350 | 2x 1,0 | 1,27 | S10C-450 | 2x 1,0 | 1,55 | G26H-550 | 2x 2,6 | 1,75 | G26H-600 | 2x 2,6 | 1,86 | G40H-830 | 2x 4,0 | 1,92 |
| 2000 x 1700 | S10C-350 | 2x 1,0 | 1,38 | S10C-450 | 2x 1,0 | 1,69 | G26H-550 | 2x 2,6 | 1,90 | G26H-600 | 2x 2,6 | 1,99 | G40H-830 | 2x 4,0 | 2,08 |
| 2100 x 800 | S08B-200 | 2x 0,8 | 0,54 | S08B-300 | 2x 0,8 | 0,70 | S08B-300 | 2x 0,8 | 0,80 | S10C-400 | 2x 1,0 | 0,86 | S10C-450 | 2x 1,0 | 0,90 |
| 2100 x 900 | S08B-200 | 2x 0,8 | 0,63 | S08B-300 | 2x 0,8 | 0,80 | S08B-300 | 2x 0,8 | 0,92 | S10C-400 | 2x 1,0 | 0,99 | G26H-550 | 2x 2,6 | 1,03 |
| 2100 x 1000 | S08B-200 | 2x 0,8 | 0,71 | S08B-300 | 2x 0,8 | 0,92 | S10C-400 | 2x 1,0 | 1,05 | G26G-450 | 2x 2,6 | 1,12 | G26H-550 | 2x 2,6 | 1,17 |
| 2100 x 1100 | S08B-200 | 2x 0,8 | 0,81 | S10C-350 | 2x 1,0 | 1,02 | S10C-400 | 2x 1,0 | 1,17 | G26G-450 | 2x 2,6 | 1,25 | G26H-550 | 2x 2,6 | 1,31 |
| 2100 x 1200 | S08B-300 | 2x 0,8 | 0,92 | S08B-300 | 2x 0,8 | 1,14 | G26G-450 | 2x 2,6 | 1,31 | G26H-550 | 2x 2,6 | 1,40 | G26H-550 | 2x 2,6 | 1,44 |
| 2100 x 1300 | S08B-300 | 2x 0,8 | 1,00 | S10C-350 | 2x 1,0 | 1,26 | G26G-450 | 2x 2,6 | 1,42 | G26H-550 | 2x 2,6 | 1,52 | G26H-600 | 2x 2,6 | 1,59 |
| 2100 x 1400 | S08B-300 | 2x 0,8 | 1,11 | S10C-350 | 2x 1,0 | 1,37 | G26G-450 | 2x 2,6 | 1,57 | G26G-450 | 2x 2,6 | 1,66 | G26H-750 | 2x 2,6 | 1,72 |
| 2100 x 1500 | S08B-300 | 2x 0,8 | 1,22 | S10C-400 | 2x 1,0 | 1,51 | G26G-450 | 2x 2,6 | 1,69 | G26H-550 | 2x 2,6 | 1,80 | G26H-750 | 2x 2,6 | 1,88 |
| 2100 x 1600 | S10C-350 | 2x 1,0 | 1,34 | S10C-450 | 2x 1,0 | 1,63 | G26H-550 | 2x 2,6 | 1,84 | G26H-600 | 2x 2,6 | 1,93 | G40H-830 | 2x 4,0 | 2,02 |
| 2200 x 800 | S08B-200 | 2x 0,8 | 0,57 | S08B-300 | 2x 0,8 | 0,73 | S08B-300 | 2x 0,8 | 0,84 | S10C-400 | 2x 1,0 | 0,90 | S10C-450 | 2x 1,0 | 0,94 |
| 2200 x 900 | S08B-200 | 2x 0,8 | 0,65 | S08B-300 | 2x 0,8 | 0,84 | S08B-300 | 2x 0,8 | 0,96 | S10C-400 | 2x 1,0 | 1,04 | G26H-550 | 2x 2,6 | 1,08 |
| 2200 x 1000 | S08B-200 | 2x 0,8 | 0,75 | S08B-300 | 2x 0,8 | 0,96 | S10C-400 | 2x 1,0 | 1,10 | G26G-450 | 2x 2,6 | 1,18 | G26H-550 | 2x 2,6 | 1,23 |
| 2200 x 1100 | S08B-200 | 2x 0,8 | 0,85 | S10C-350 | 2x 1,0 | 1,07 | S10C-400 | 2x 1,0 | 1,23 | G26G-450 | 2x 2,6 | 1,31 | G26H-550 | 2x 2,6 | 1,37 |
| 2200 x 1200 | S08B-300 | 2x 0,8 | 0,93 | S08B-300 | 2x 0,8 | 1,20 | G26G-450 | 2x 2,6 | 1,37 | G26H-550 | 2x 2,6 | 1,45 | G26H-550 | 2x 2,6 | 1,50 |
| 2200 x 1300 | S08B-300 | 2x 0,8 | 1,05 | S10C-350 | 2x 1,0 | 1,32 | G26G-450 | 2x 2,6 | 1,49 | G26H-550 | 2x 2,6 | 1,59 | G26H-600 | 2x 2,6 | 1,67 |

(*) It is possible to make intermediate dimensions of the smoke exhaust window between the values given in the table. The size of the active aerodynamic area for these dimensions is determined by linear interpolation.
 (***) Smoke exhaust windows are equipped with a set of two spindle actuators. Power consumption is given for a set of two actuators.

1.2.5.1. technical specification - types of smoke exhaust windows opening outwards by means of spindle actuators

| WINDOW SIZE* | OPENING ANGLE 30° | | | OPENING ANGLE 45° | | | OPENING ANGLE 60° | | | OPENING ANGLE 75° | | | OPENING ANGLE 90° | | |
|--------------|-------------------|-------------------------|-----------------------------------|-------------------|-------------------------|-----------------------------------|-------------------|-------------------------|-----------------------------------|-------------------|-------------------------|-----------------------------------|-------------------|-------------------------|-----------------------------------|
| | ACTUATOR | POWER CONSUMPTION** [A] | ACTIVE AERODYNAMIC AREA [Aa] [m²] | ACTUATOR | POWER CONSUMPTION** [A] | ACTIVE AERODYNAMIC AREA [Aa] [m²] | ACTUATOR | POWER CONSUMPTION** [A] | ACTIVE AERODYNAMIC AREA [Aa] [m²] | ACTUATOR | POWER CONSUMPTION** [A] | ACTIVE AERODYNAMIC AREA [Aa] [m²] | ACTUATOR | POWER CONSUMPTION** [A] | ACTIVE AERODYNAMIC AREA [Aa] [m²] |
| B' x H' | | | | | | | | | | | | | | | |
| [mm] | | | | | | | | | | | | | | | |
| 2200 x 1400 | S08B-300 | 2x0,8 | 1,16 | S10C-350 | 2x1,0 | 1,44 | G26G-450 | 2x2,6 | 1,65 | G26G-450 | 2x2,6 | 1,74 | G26H-750 | 2x2,6 | 1,81 |
| 2200 x 1500 | S08B-300 | 2x0,8 | 1,28 | S10C-400 | 2x1,0 | 1,57 | G26G-450 | 2x2,6 | 1,78 | G26H-550 | 2x2,6 | 1,89 | G26H-750 | 2x2,6 | 1,95 |
| 2200 x 1600 | S10C-350 | 2x1,0 | 1,37 | S10C-450 | 2x1,0 | 1,72 | G26H-550 | 2x2,6 | 1,93 | G26H-600 | 2x2,6 | 2,03 | G40H-830 | 2x4,0 | 2,12 |
| 2300 x 800 | S08B-200 | 2x0,8 | 0,59 | S08B-300 | 2x0,8 | 0,76 | S08B-300 | 2x0,8 | 0,88 | S10C-400 | 2x1,0 | 0,94 | S10C-450 | 2x1,0 | 0,99 |
| 2300 x 900 | S08B-200 | 2x0,8 | 0,68 | S08B-300 | 2x0,8 | 0,88 | S08B-300 | 2x0,8 | 1,01 | S10C-400 | 2x1,0 | 1,09 | G26H-550 | 2x2,6 | 1,13 |
| 2300 x 1000 | S08B-200 | 2x0,8 | 0,78 | S08B-300 | 2x0,8 | 1,00 | S10C-400 | 2x1,0 | 1,16 | G26G-450 | 2x2,6 | 1,23 | G26H-550 | 2x2,6 | 1,29 |
| 2300 x 1100 | S08B-200 | 2x0,8 | 0,89 | S10C-350 | 2x1,0 | 1,12 | S10C-400 | 2x1,0 | 1,28 | G26G-450 | 2x2,6 | 1,37 | G26H-550 | 2x2,6 | 1,43 |
| 2300 x 1200 | S08B-300 | 2x0,8 | 0,98 | S08B-300 | 2x0,8 | 1,25 | G26G-450 | 2x2,6 | 1,43 | G26H-550 | 2x2,6 | 1,52 | G26H-550 | 2x2,6 | 1,58 |
| 2300 x 1300 | S08B-300 | 2x0,8 | 1,10 | S10C-350 | 2x1,0 | 1,37 | G26G-450 | 2x2,6 | 1,57 | G26H-550 | 2x2,6 | 1,67 | G26H-600 | 2x2,6 | 1,75 |
| 2300 x 1400 | S08B-300 | 2x0,8 | 1,22 | S10C-350 | 2x1,0 | 1,51 | G26G-450 | 2x2,6 | 1,73 | G26G-450 | 2x2,6 | 1,81 | G26H-750 | 2x2,6 | 1,90 |
| 2300 x 1500 | S08B-300 | 2x0,8 | 1,31 | S10C-400 | 2x1,0 | 1,65 | G26G-450 | 2x2,6 | 1,86 | G26H-550 | 2x2,6 | 1,98 | G26H-750 | 2x2,6 | 2,04 |
| 2400 x 800 | S08B-200 | 2x0,8 | 0,62 | S08B-300 | 2x0,8 | 0,80 | S08B-300 | 2x0,8 | 0,92 | S10C-400 | 2x1,0 | 0,99 | G26H-550 | 2x2,6 | 1,03 |
| 2400 x 900 | S08B-200 | 2x0,8 | 0,71 | S08B-300 | 2x0,8 | 0,92 | S08B-300 | 2x0,8 | 1,06 | G26G-450 | 2x2,6 | 1,14 | G26H-550 | 2x2,6 | 1,18 |
| 2400 x 1000 | S08B-200 | 2x0,8 | 0,82 | S08B-300 | 2x0,8 | 1,03 | S10C-400 | 2x1,0 | 1,20 | G26G-450 | 2x2,6 | 1,29 | G26H-550 | 2x2,6 | 1,35 |
| 2400 x 1100 | S08B-200 | 2x0,8 | 0,91 | S10C-350 | 2x1,0 | 1,17 | S10C-400 | 2x1,0 | 1,34 | G26G-450 | 2x2,6 | 1,43 | G26H-550 | 2x2,6 | 1,50 |
| 2400 x 1200 | S08B-300 | 2x0,8 | 1,03 | S08B-300 | 2x0,8 | 1,30 | G26G-450 | 2x2,6 | 1,50 | G26H-550 | 2x2,6 | 1,59 | G26H-550 | 2x2,6 | 1,65 |
| 2400 x 1300 | S08B-300 | 2x0,8 | 1,15 | S10C-350 | 2x1,0 | 1,43 | G26G-450 | 2x2,6 | 1,64 | G26H-550 | 2x2,6 | 1,75 | G26H-600 | 2x2,6 | 1,83 |
| 2400 x 1400 | S08B-300 | 2x0,8 | 1,24 | S10C-350 | 2x1,0 | 1,58 | G26G-450 | 2x2,6 | 1,81 | G26G-450 | 2x2,6 | 1,89 | G26H-750 | 2x2,6 | 1,98 |
| 2500 x 800 | S08B-200 | 2x0,8 | 0,65 | S08B-300 | 2x0,8 | 0,83 | S08B-300 | 2x0,8 | 0,96 | S10C-400 | 2x1,0 | 1,03 | G26H-550 | 2x2,6 | 1,08 |
| 2500 x 900 | S08B-200 | 2x0,8 | 0,74 | S08B-300 | 2x0,8 | 0,95 | S08B-300 | 2x0,8 | 1,10 | G26G-450 | 2x2,6 | 1,18 | G26H-550 | 2x2,6 | 1,23 |
| 2500 x 1000 | S08B-200 | 2x0,8 | 0,85 | S08B-300 | 2x0,8 | 1,08 | S10C-400 | 2x1,0 | 1,26 | G26G-450 | 2x2,6 | 1,33 | G26H-550 | 2x2,6 | 1,38 |
| 2500 x 1100 | S08B-200 | 2x0,8 | 0,95 | S10C-350 | 2x1,0 | 1,22 | S10C-400 | 2x1,0 | 1,40 | G26G-450 | 2x2,6 | 1,49 | G26H-550 | 2x2,6 | 1,56 |
| 2500 x 1200 | S08B-300 | 2x0,8 | 1,07 | S08B-300 | 2x0,8 | 1,34 | G26G-450 | 2x2,6 | 1,54 | G26H-550 | 2x2,6 | 1,66 | G26H-550 | 2x2,6 | 1,72 |
| 2500 x 1300 | S08B-300 | 2x0,8 | 1,20 | S10C-350 | 2x1,0 | 1,50 | G26G-450 | 2x2,6 | 1,71 | G26H-550 | 2x2,6 | 1,82 | G26H-600 | 2x2,6 | 1,88 |
| 2500 x 1400 | S08B-300 | 2x0,8 | 1,30 | S10C-350 | 2x1,0 | 1,64 | G26G-450 | 2x2,6 | 1,85 | G26G-450 | 2x2,6 | 1,98 | G26H-750 | 2x2,6 | 2,07 |
| 2600 x 800 | S08B-200 | 2x0,8 | 0,67 | S08B-300 | 2x0,8 | 0,85 | S08B-300 | 2x0,8 | 1,00 | S10C-400 | 2x1,0 | 1,07 | G26H-550 | 2x2,6 | 1,12 |
| 2600 x 900 | S08B-200 | 2x0,8 | 0,77 | S08B-300 | 2x0,8 | 0,99 | S08B-300 | 2x0,8 | 1,14 | G26G-450 | 2x2,6 | 1,23 | G26H-550 | 2x2,6 | 1,28 |
| 2600 x 1000 | S08B-200 | 2x0,8 | 0,89 | S08B-300 | 2x0,8 | 1,12 | S10C-400 | 2x1,0 | 1,31 | G26G-450 | 2x2,6 | 1,39 | G26H-550 | 2x2,6 | 1,44 |

(*) It is possible to make intermediate dimensions of the smoke exhaust window between the values given in the table. The size of the active aerodynamic area for these dimensions is determined by linear interpolation.
 (***) Smoke exhaust windows are equipped with a set of two spindle actuators.

1.2.5.1. technical specification - types of smoke exhaust windows opening outwards by means of spindle actuators

| WINDOW SIZE* B' x H' [mm] | OPENING ANGLE 30° | | | OPENING ANGLE 45° | | | OPENING ANGLE 60° | | | OPENING ANGLE 75° | | | OPENING ANGLE 90° | | |
|---------------------------------|-------------------|--------------------------|-----------------------------------|-------------------|--------------------------|-----------------------------------|-------------------|--------------------------|-----------------------------------|-------------------|--------------------------|-----------------------------------|-------------------|--------------------------|-----------------------------------|
| | ACTUATOR | POWER CON-SUMPTION** [A] | ACTIVE AERODYNAMIC AREA [Aa] [m²] | ACTUATOR | POWER CON-SUMPTION** [A] | ACTIVE AERODYNAMIC AREA [Aa] [m²] | ACTUATOR | POWER CON-SUMPTION** [A] | ACTIVE AERODYNAMIC AREA [Aa] [m²] | ACTUATOR | POWER CON-SUMPTION** [A] | ACTIVE AERODYNAMIC AREA [Aa] [m²] | ACTUATOR | POWER CON-SUMPTION** [A] | ACTIVE AERODYNAMIC AREA [Aa] [m²] |
| 2600 x 1100 | S08B-200 | 2x 0,8 | 0,99 | S10C-350 | 2x 1,0 | 1,27 | S10C-400 | 2x 1,0 | 1,46 | G26G-450 | 2x 2,6 | 1,56 | G26H-550 | 2x 2,6 | 1,63 |
| 2600 x 1200 | S08B-300 | 2x 0,8 | 1,12 | S08B-300 | 2x 0,8 | 1,40 | G26G-450 | 2x 2,6 | 1,60 | G26H-550 | 2x 2,6 | 1,71 | G26H-550 | 2x 2,6 | 1,80 |
| 2600 x 1300 | S08B-300 | 2x 0,8 | 1,25 | S10C-350 | 2x 1,0 | 1,56 | G26G-450 | 2x 2,6 | 1,78 | G26H-550 | 2x 2,6 | 1,90 | G26H-600 | 2x 2,6 | 1,96 |
| 2700 x 800 | S08B-200 | 2x 0,8 | 0,70 | S08B-300 | 2x 0,8 | 0,89 | S08B-300 | 2x 0,8 | 1,04 | S10C-400 | 2x 1,0 | 1,11 | G26H-550 | 2x 2,6 | 1,16 |
| 2700 x 900 | S08B-200 | 2x 0,8 | 0,80 | S08B-300 | 2x 0,8 | 1,04 | S08B-300 | 2x 0,8 | 1,19 | G26G-450 | 2x 2,6 | 1,28 | G26H-550 | 2x 2,6 | 1,33 |
| 2700 x 1000 | S08B-200 | 2x 0,8 | 0,92 | S08B-300 | 2x 0,8 | 1,17 | S10C-400 | 2x 1,0 | 1,36 | G26G-450 | 2x 2,6 | 1,44 | G26H-550 | 2x 2,6 | 1,50 |
| 2700 x 1100 | S08B-200 | 2x 0,8 | 1,03 | S10C-350 | 2x 1,0 | 1,32 | S10C-400 | 2x 1,0 | 1,52 | G26G-450 | 2x 2,6 | 1,62 | G26H-550 | 2x 2,6 | 1,70 |
| 2700 x 1200 | S08B-300 | 2x 0,8 | 1,16 | S08B-300 | 2x 0,8 | 1,46 | G26G-450 | 2x 2,6 | 1,67 | G26H-550 | 2x 2,6 | 1,78 | G26H-550 | 2x 2,6 | 1,87 |
| 2700 x 1300 | S08B-300 | 2x 0,8 | 1,27 | S10C-350 | 2x 1,0 | 1,62 | G26G-450 | 2x 2,6 | 1,85 | G26H-550 | 2x 2,6 | 1,96 | G26H-600 | 2x 2,6 | 2,04 |

(*) It is possible to make intermediate dimensions of the smoke exhaust window between the values given in the table. The size of the active aerodynamic area for these dimensions is determined by linear interpolation.

(**) Smoke exhaust windows are equipped with a set of two spindle actuators. Power consumption is given for a set of two actuators.

1.2.5.2. types of inward-opening smoke exhaust windows with chain actuators

bottom hung windows

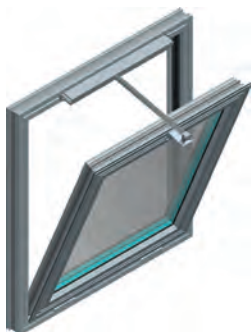


Fig. 103 - mcr OSO THERM 75 smoke exhaust window with KR10B / HCV chain actuator



Fig. 104 - mcr OSO THERM 75 smoke exhaust window with two KR10B / HCV chain actuatorsV

top-hung windows

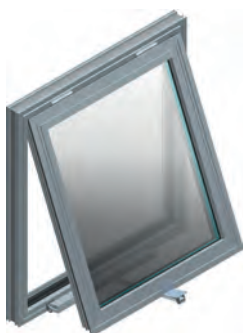


Fig. 105 - mcr OSO THERM 75 smoke exhaust window with KR10B / HCV chain actuator



Fig. 106 - mcr OSO THERM 75 smoke exhaust window with two KR10B / HCV chain actuators

1.2.5.2. technical specification - top- and bottom-opening smoke exhaust windows opening inwards with chain actuators

| WINDOW SIZE** | ACTUATOR* | POWER CONSUMPTION FOR 24 V- / 48 V-*** | OPENING ANGLE | ACTIVE AERODYNAMIC AREA [Aa] |
|---------------|------------|--|---------------|------------------------------|
| B' x H' | | | | |
| [mm] | - | [A] | [°] | [m²] |
| 800 x 800 | KR10B-400 | 1,0 | 31 | 0,20 |
| 800 x 800 | HCV500/350 | 1,4 / 0,7 | 27 | 0,18 |
| 800 x 900 | KR10B-400 | 1,0 | 27 | 0,21 |
| 800 x 900 | HCV500/350 | 1,4 / 0,7 | 24 | 0,19 |
| 800 x 1000 | KR10B-400 | 1,0 | 24 | 0,23 |
| 800 x 1000 | HCV500/350 | 1,4 / 0,7 | 21 | 0,20 |
| 800 x 1100 | KR10B-400 | 1,0 | 22 | 0,24 |
| 800 x 1100 | HCV500/600 | 1,4 / 0,7 | 33 | 0,32 |
| 800 x 1100 | HCV500/350 | 1,4 / 0,7 | 19 | 0,21 |
| 800 x 1200 | KR10B-400 | 1,0 | 20 | 0,25 |
| 800 x 1200 | HCV500/600 | 1,4 / 0,7 | 30 | 0,34 |
| 800 x 1200 | HCV500/350 | 1,4 / 0,7 | 17 | 0,22 |
| 800 x 1300 | KR10B-400 | 1,0 | 19 | 0,26 |
| 800 x 1300 | HCV500/600 | 1,4 / 0,7 | 28 | 0,36 |
| 800 x 1300 | HCV500/350 | 1,4 / 0,7 | 16 | 0,23 |
| 800 x 1400 | KR10B-400 | 1,0 | 17 | 0,28 |
| 800 x 1400 | HCV500/600 | 1,4 / 0,7 | 26 | 0,37 |
| 800 x 1400 | HCV500/350 | 1,4 / 0,7 | 15 | 0,25 |
| 800 x 1500 | KR10B-400 | 1,0 | 16 | 0,29 |
| 800 x 1500 | HCV500/600 | 1,4 / 0,7 | 24 | 0,39 |
| 800 x 1500 | HCV500/350 | 1,4 / 0,7 | 14 | 0,26 |
| 800 x 1600 | KR10B-400 | 1,0 | 15 | 0,31 |
| 800 x 1600 | HCV500/600 | 1,4 / 0,7 | 22 | 0,42 |
| 800 x 1600 | HCV500/350 | 1,4 / 0,7 | 13 | 0,27 |
| 800 x 1700 | KR10B-400 | 1,0 | 14 | 0,32 |
| 800 x 1700 | HCV500/600 | 1,4 / 0,7 | 21 | 0,44 |
| 800 x 1700 | HCV500/350 | 1,4 / 0,7 | 12 | 0,29 |
| 800 x 1800 | KR10B-400 | 1,0 | 13 | 0,34 |
| 800 x 1800 | HCV500/600 | 1,4 / 0,7 | 20 | 0,46 |
| 800 x 1800 | HCV500/350 | 1,4 / 0,7 | 11 | 0,31 |
| 800 x 1900 | KR10B-400 | 1,0 | 12 | 0,36 |
| 800 x 1900 | HCV500/600 | 1,4 / 0,7 | 19 | 0,48 |
| 800 x 1900 | HCV500/350 | 1,4 / 0,7 | 11 | 0,33 |
| 800 x 2000 | KR10B-400 | 1,0 | 12 | 0,38 |
| 800 x 2000 | HCV500/600 | 1,4 / 0,7 | 18 | 0,50 |
| 800 x 2000 | HCV500/350 | 1,4 / 0,7 | 10 | 0,34 |
| 800 x 2100 | KR10B-400 | 1,0 | 11 | 0,40 |
| 800 x 2100 | HCV500/600 | 1,4 / 0,7 | 17 | 0,52 |
| 800 x 2100 | HCV500/350 | 1,4 / 0,7 | 10 | 0,29 |
| 800 x 2200 | KR10B-400 | 1,0 | 11 | 0,42 |
| 800 x 2200 | HCV500/600 | 1,4 / 0,7 | 16 | 0,55 |
| 800 x 2200 | HCV500/350 | 1,4 / 0,7 | 9 | 0,30 |
| 900 x 800 | KR10B-500 | 1,0 | 39 | 0,26 |
| 900 x 800 | KR10B-400 | 1,0 | 31 | 0,23 |

| WINDOW SIZE** | ACTUATOR* | POWER CONSUMPTION FOR 24 V- / 48 V-*** | OPENING ANGLE | ACTIVE AERODYNAMIC AREA [Aa] |
|---------------|------------|--|---------------|------------------------------|
| B' x H' | | | | |
| [mm] | - | [A] | [°] | [m²] |
| 900 x 800 | HCV500/350 | 1,4 / 0,7 | 27 | 0,21 |
| 900 x 900 | KR10B-500 | 1,0 | 34 | 0,28 |
| 900 x 900 | KR10B-400 | 1,0 | 27 | 0,25 |
| 900 x 900 | HCV500/350 | 1,4 / 0,7 | 24 | 0,22 |
| 900 x 1000 | KR10B-500 | 1,0 | 31 | 0,31 |
| 900 x 1000 | KR10B-400 | 1,0 | 24 | 0,26 |
| 900 x 1000 | HCV500/350 | 1,4 / 0,7 | 21 | 0,23 |
| 900 x 1100 | KR10B-500 | 1,0 | 28 | 0,33 |
| 900 x 1100 | KR10B-400 | 1,0 | 22 | 0,27 |
| 900 x 1100 | HCV500/600 | 1,4 / 0,7 | 33 | 0,37 |
| 900 x 1100 | HCV500/350 | 1,4 / 0,7 | 19 | 0,24 |
| 900 x 1200 | KR10B-500 | 1,0 | 25 | 0,34 |
| 900 x 1200 | KR10B-400 | 1,0 | 20 | 0,29 |
| 900 x 1200 | HCV500/600 | 1,4 / 0,7 | 30 | 0,39 |
| 900 x 1200 | HCV500/350 | 1,4 / 0,7 | 17 | 0,25 |
| 900 x 1300 | KR10B-500 | 1,0 | 23 | 0,36 |
| 900 x 1300 | KR10B-400 | 1,0 | 19 | 0,30 |
| 900 x 1300 | HCV500/600 | 1,4 / 0,7 | 28 | 0,41 |
| 900 x 1300 | HCV500/350 | 1,4 / 0,7 | 16 | 0,26 |
| 900 x 1400 | KR10B-500 | 1,0 | 21 | 0,37 |
| 900 x 1400 | KR10B-400 | 1,0 | 17 | 0,31 |
| 900 x 1400 | HCV500/600 | 1,4 / 0,7 | 26 | 0,43 |
| 900 x 1400 | HCV500/350 | 1,4 / 0,7 | 15 | 0,28 |
| 900 x 1500 | KR10B-500 | 1,0 | 20 | 0,40 |
| 900 x 1500 | KR10B-400 | 1,0 | 16 | 0,33 |
| 900 x 1500 | HCV500/600 | 1,4 / 0,7 | 24 | 0,45 |
| 900 x 1500 | HCV500/350 | 1,4 / 0,7 | 14 | 0,29 |
| 900 x 1600 | KR10B-500 | 1,0 | 19 | 0,41 |
| 900 x 1600 | KR10B-400 | 1,0 | 15 | 0,35 |
| 900 x 1600 | HCV500/600 | 1,4 / 0,7 | 22 | 0,47 |
| 900 x 1600 | HCV500/350 | 1,4 / 0,7 | 13 | 0,31 |
| 900 x 1700 | KR10B-500 | 1,0 | 18 | 0,43 |
| 900 x 1700 | KR10B-400 | 1,0 | 14 | 0,37 |
| 900 x 1700 | HCV500/600 | 1,4 / 0,7 | 21 | 0,49 |
| 900 x 1700 | HCV500/350 | 1,4 / 0,7 | 12 | 0,33 |
| 900 x 1800 | KR10B-500 | 1,0 | 17 | 0,45 |
| 900 x 1800 | KR10B-400 | 1,0 | 13 | 0,39 |
| 900 x 1800 | HCV500/600 | 1,4 / 0,7 | 20 | 0,52 |
| 900 x 1800 | HCV500/350 | 1,4 / 0,7 | 11 | 0,35 |
| 900 x 1900 | KR10B-500 | 1,0 | 16 | 0,47 |
| 900 x 1900 | KR10B-400 | 1,0 | 12 | 0,41 |
| 900 x 1900 | HCV500/600 | 1,4 / 0,7 | 19 | 0,54 |
| 900 x 1900 | HCV500/350 | 1,4 / 0,7 | 11 | 0,37 |
| 900 x 2000 | KR10B-500 | 1,0 | 15 | 0,51 |

1.2.5.2. technical specification - top- and bottom-opening smoke exhaust windows opening inwards with chain actuators

| WINDOW SIZE** | ACTUATOR* | POWER CONSUMPTION FOR 24 V- / 48 V-*** | OPENING ANGLE | ACTIVE AERODYNAMIC AREA [Aa] |
|---------------|------------|--|---------------|------------------------------|
| B' x H' | | | | |
| [mm] | - | [A] | [°] | [m ²] |
| 900 x 2000 | KR10B-400 | 1,0 | 12 | 0,43 |
| 900 x 2000 | HCV500/600 | 1,4 / 0,7 | 18 | 0,57 |
| 900 x 2000 | HCV500/350 | 1,4 / 0,7 | 10 | 0,39 |
| 900 x 2100 | KR10B-500 | 1,0 | 14 | 0,53 |
| 900 x 2100 | KR10B-400 | 1,0 | 11 | 0,46 |
| 900 x 2100 | HCV500/600 | 1,4 / 0,7 | 17 | 0,60 |
| 900 x 2100 | HCV500/350 | 1,4 / 0,7 | 10 | 0,33 |
| 900 x 2200 | KR10B-500 | 1,0 | 13 | 0,54 |
| 900 x 2200 | KR10B-400 | 1,0 | 11 | 0,47 |
| 900 x 2200 | HCV500/600 | 1,4 / 0,7 | 16 | 0,62 |
| 900 x 2200 | HCV500/350 | 1,4 / 0,7 | 9 | 0,35 |
| 1000 x 800 | KR10B-500 | 1,0 | 39 | 0,29 |
| 1000 x 800 | KR10B-400 | 1,0 | 31 | 0,25 |
| 1000 x 800 | HCV500/350 | 1,4 / 0,7 | 27 | 0,23 |
| 1000 x 900 | KR10B-600 | 1,0 | 42 | 0,36 |
| 1000 x 900 | KR10B-500 | 1,0 | 34 | 0,32 |
| 1000 x 900 | KR10B-400 | 1,0 | 27 | 0,27 |
| 1000 x 900 | HCV500/350 | 1,4 / 0,7 | 24 | 0,24 |
| 1000 x 1000 | KR10B-600 | 1,0 | 37 | 0,38 |
| 1000 x 1000 | KR10B-500 | 1,0 | 31 | 0,34 |
| 1000 x 1000 | KR10B-400 | 1,0 | 24 | 0,28 |
| 1000 x 1000 | HCV500/350 | 1,4 / 0,7 | 21 | 0,25 |
| 1000 x 1100 | KR10B-600 | 1,0 | 33 | 0,40 |
| 1000 x 1100 | KR10B-500 | 1,0 | 28 | 0,35 |
| 1000 x 1100 | KR10B-400 | 1,0 | 22 | 0,30 |
| 1000 x 1100 | HCV500/600 | 1,4 / 0,7 | 33 | 0,40 |
| 1000 x 1100 | HCV500/350 | 1,4 / 0,7 | 19 | 0,26 |
| 1000 x 1200 | KR10B-600 | 1,0 | 30 | 0,43 |
| 1000 x 1200 | KR10B-500 | 1,0 | 25 | 0,37 |
| 1000 x 1200 | KR10B-400 | 1,0 | 20 | 0,31 |
| 1000 x 1200 | HCV500/600 | 1,4 / 0,7 | 30 | 0,43 |
| 1000 x 1200 | HCV500/350 | 1,4 / 0,7 | 17 | 0,28 |
| 1000 x 1300 | KR10B-600 | 1,0 | 28 | 0,45 |
| 1000 x 1300 | KR10B-500 | 1,0 | 23 | 0,39 |
| 1000 x 1300 | KR10B-400 | 1,0 | 19 | 0,33 |
| 1000 x 1300 | HCV500/600 | 1,4 / 0,7 | 28 | 0,45 |
| 1000 x 1300 | HCV500/350 | 1,4 / 0,7 | 16 | 0,29 |
| 1000 x 1400 | KR10B-600 | 1,0 | 26 | 0,47 |
| 1000 x 1400 | KR10B-500 | 1,0 | 21 | 0,41 |
| 1000 x 1400 | KR10B-400 | 1,0 | 17 | 0,34 |
| 1000 x 1400 | HCV500/600 | 1,4 / 0,7 | 26 | 0,47 |
| 1000 x 1400 | HCV500/350 | 1,4 / 0,7 | 15 | 0,31 |
| 1000 x 1500 | KR10B-600 | 1,0 | 24 | 0,49 |
| 1000 x 1500 | KR10B-500 | 1,0 | 20 | 0,43 |

| WINDOW SIZE** | ACTUATOR* | POWER CONSUMPTION FOR 24 V- / 48 V-*** | OPENING ANGLE | ACTIVE AERODYNAMIC AREA [Aa] |
|---------------|------------|--|---------------|------------------------------|
| B' x H' | | | | |
| [mm] | - | [A] | [°] | [m ²] |
| 1000 x 1500 | KR10B-400 | 1,0 | 16 | 0,36 |
| 1000 x 1500 | HCV500/800 | 1,4 / 0,7 | 32 | 0,60 |
| 1000 x 1500 | HCV500/600 | 1,4 / 0,7 | 24 | 0,49 |
| 1000 x 1500 | HCV500/350 | 1,4 / 0,7 | 14 | 0,33 |
| 1000 x 1600 | KR10B-600 | 1,0 | 22 | 0,53 |
| 1000 x 1600 | KR10B-500 | 1,0 | 19 | 0,46 |
| 1000 x 1600 | KR10B-400 | 1,0 | 15 | 0,38 |
| 1000 x 1600 | HCV500/800 | 1,4 / 0,7 | 30 | 0,64 |
| 1000 x 1600 | HCV500/600 | 1,4 / 0,7 | 22 | 0,53 |
| 1000 x 1600 | HCV500/350 | 1,4 / 0,7 | 13 | 0,34 |
| 1000 x 1700 | KR10B-600 | 1,0 | 21 | 0,56 |
| 1000 x 1700 | KR10B-500 | 1,0 | 18 | 0,48 |
| 1000 x 1700 | KR10B-400 | 1,0 | 14 | 0,40 |
| 1000 x 1700 | HCV500/800 | 1,4 / 0,7 | 28 | 0,67 |
| 1000 x 1700 | HCV500/600 | 1,4 / 0,7 | 21 | 0,55 |
| 1000 x 1700 | HCV500/350 | 1,4 / 0,7 | 12 | 0,36 |
| 1000 x 1800 | KR10B-600 | 1,0 | 20 | 0,58 |
| 1000 x 1800 | KR10B-500 | 1,0 | 17 | 0,50 |
| 1000 x 1800 | KR10B-400 | 1,0 | 13 | 0,42 |
| 1000 x 1800 | HCV500/800 | 1,4 / 0,7 | 26 | 0,70 |
| 1000 x 1800 | HCV500/600 | 1,4 / 0,7 | 20 | 0,58 |
| 1000 x 1800 | HCV500/350 | 1,4 / 0,7 | 11 | 0,38 |
| 1000 x 1900 | KR10B-600 | 1,0 | 19 | 0,61 |
| 1000 x 1900 | KR10B-500 | 1,0 | 16 | 0,53 |
| 1000 x 1900 | KR10B-400 | 1,0 | 12 | 0,45 |
| 1000 x 1900 | HCV500/800 | 1,4 / 0,7 | 25 | 0,73 |
| 1000 x 1900 | HCV500/600 | 1,4 / 0,7 | 19 | 0,61 |
| 1000 x 1900 | HCV500/350 | 1,4 / 0,7 | 11 | 0,40 |
| 1000 x 2000 | KR10B-600 | 1,0 | 18 | 0,63 |
| 1000 x 2000 | KR10B-500 | 1,0 | 15 | 0,55 |
| 1000 x 2000 | KR10B-400 | 1,0 | 12 | 0,47 |
| 1000 x 2000 | HCV500/800 | 1,4 / 0,7 | 24 | 0,76 |
| 1000 x 2000 | HCV500/600 | 1,4 / 0,7 | 18 | 0,63 |
| 1000 x 2000 | HCV500/350 | 1,4 / 0,7 | 10 | 0,43 |
| 1000 x 2100 | KR10B-600 | 1,0 | 17 | 0,66 |
| 1000 x 2100 | KR10B-500 | 1,0 | 14 | 0,58 |
| 1000 x 2100 | KR10B-400 | 1,0 | 11 | 0,50 |
| 1000 x 2100 | HCV500/800 | 1,4 / 0,7 | 23 | 0,80 |
| 1000 x 2100 | HCV500/600 | 1,4 / 0,7 | 17 | 0,66 |
| 1000 x 2100 | HCV500/350 | 1,4 / 0,7 | 10 | 0,37 |
| 1000 x 2200 | KR10B-600 | 1,0 | 16 | 0,69 |
| 1000 x 2200 | KR10B-500 | 1,0 | 13 | 0,61 |
| 1000 x 2200 | KR10B-400 | 1,0 | 11 | 0,53 |
| 1000 x 2200 | HCV500/800 | 1,4 / 0,7 | 21 | 0,84 |

1.2.5.2. technical specification - top- and bottom-opening smoke exhaust windows opening inwards with chain actuators

| WINDOW SIZE** | ACTUATOR* | POWER CONSUMPTION FOR 24 V- / 48 V-*** | OPENING ANGLE | ACTIVE AERODYNAMIC AREA [Aa] |
|---------------|------------|--|---------------|------------------------------|
| B' x H' | | | | |
| [mm] | - | [A] | [°] | [m ²] |
| 1000 x 2200 | HCV500/600 | 1,4 / 0,7 | 16 | 0,68 |
| 1000 x 2200 | HCV500/350 | 1,4 / 0,7 | 9 | 0,39 |
| 1100 x 800 | KR10B-500 | 1,0 | 39 | 0,33 |
| 1100 x 800 | KR10B-400 | 1,0 | 31 | 0,28 |
| 1100 x 800 | HCV500/350 | 1,4 / 0,7 | 27 | 0,25 |
| 1100 x 900 | KR10B-600 | 1,0 | 42 | 0,39 |
| 1100 x 900 | KR10B-500 | 1,0 | 34 | 0,35 |
| 1100 x 900 | KR10B-400 | 1,0 | 27 | 0,30 |
| 1100 x 900 | HCV500/350 | 1,4 / 0,7 | 24 | 0,26 |
| 1100 x 1000 | KR10B-600 | 1,0 | 37 | 0,41 |
| 1100 x 1000 | KR10B-500 | 1,0 | 31 | 0,37 |
| 1100 x 1000 | KR10B-400 | 1,0 | 24 | 0,31 |
| 1100 x 1000 | HCV500/350 | 1,4 / 0,7 | 21 | 0,28 |
| 1100 x 1100 | KR10B-600 | 1,0 | 33 | 0,44 |
| 1100 x 1100 | KR10B-500 | 1,0 | 28 | 0,39 |
| 1100 x 1100 | KR10B-400 | 1,0 | 22 | 0,33 |
| 1100 x 1100 | HCV500/600 | 1,4 / 0,7 | 33 | 0,44 |
| 1100 x 1100 | HCV500/350 | 1,4 / 0,7 | 19 | 0,29 |
| 1100 x 1200 | KR10B-600 | 1,0 | 30 | 0,48 |
| 1100 x 1200 | KR10B-500 | 1,0 | 25 | 0,41 |
| 1100 x 1200 | KR10B-400 | 1,0 | 20 | 0,35 |
| 1100 x 1200 | HCV500/600 | 1,4 / 0,7 | 30 | 0,48 |
| 1100 x 1200 | HCV500/350 | 1,4 / 0,7 | 17 | 0,31 |
| 1100 x 1300 | KR10B-600 | 1,0 | 28 | 0,50 |
| 1100 x 1300 | KR10B-500 | 1,0 | 23 | 0,43 |
| 1100 x 1300 | KR10B-400 | 1,0 | 19 | 0,37 |
| 1100 x 1300 | HCV500/600 | 1,4 / 0,7 | 28 | 0,50 |
| 1100 x 1300 | HCV500/350 | 1,4 / 0,7 | 16 | 0,32 |
| 1100 x 1400 | KR10B-600 | 1,0 | 26 | 0,52 |
| 1100 x 1400 | KR10B-500 | 1,0 | 21 | 0,46 |
| 1100 x 1400 | KR10B-400 | 1,0 | 17 | 0,38 |
| 1100 x 1400 | HCV500/600 | 1,4 / 0,7 | 26 | 0,52 |
| 1100 x 1400 | HCV500/350 | 1,4 / 0,7 | 15 | 0,34 |
| 1100 x 1500 | KR10B-600 | 1,0 | 24 | 0,55 |
| 1100 x 1500 | KR10B-500 | 1,0 | 20 | 0,48 |
| 1100 x 1500 | KR10B-400 | 1,0 | 16 | 0,40 |
| 1100 x 1500 | HCV500/800 | 1,4 / 0,7 | 32 | 0,67 |
| 1100 x 1500 | HCV500/600 | 1,4 / 0,7 | 24 | 0,55 |
| 1100 x 1500 | HCV500/350 | 1,4 / 0,7 | 14 | 0,35 |
| 1100 x 1600 | KR10B-600 | 1,0 | 22 | 0,58 |
| 1100 x 1600 | KR10B-500 | 1,0 | 19 | 0,50 |
| 1100 x 1600 | KR10B-400 | 1,0 | 15 | 0,42 |
| 1100 x 1600 | HCV500/800 | 1,4 / 0,7 | 30 | 0,71 |
| 1100 x 1600 | HCV500/600 | 1,4 / 0,7 | 22 | 0,57 |

| WINDOW SIZE** | ACTUATOR* | POWER CONSUMPTION FOR 24 V- / 48 V-*** | OPENING ANGLE | ACTIVE AERODYNAMIC AREA [Aa] |
|---------------|------------|--|---------------|------------------------------|
| B' x H' | | | | |
| [mm] | - | [A] | [°] | [m ²] |
| 1100 x 1600 | HCV500/350 | 1,4 / 0,7 | 13 | 0,37 |
| 1100 x 1700 | KR10B-600 | 1,0 | 21 | 0,60 |
| 1100 x 1700 | KR10B-500 | 1,0 | 18 | 0,53 |
| 1100 x 1700 | KR10B-400 | 1,0 | 14 | 0,44 |
| 1100 x 1700 | HCV500/800 | 1,4 / 0,7 | 28 | 0,74 |
| 1100 x 1700 | HCV500/600 | 1,4 / 0,7 | 21 | 0,60 |
| 1100 x 1700 | HCV500/350 | 1,4 / 0,7 | 12 | 0,40 |
| 1100 x 1800 | KR10B-600 | 1,0 | 20 | 0,63 |
| 1100 x 1800 | KR10B-500 | 1,0 | 17 | 0,55 |
| 1100 x 1800 | KR10B-400 | 1,0 | 13 | 0,47 |
| 1100 x 1800 | HCV500/800 | 1,4 / 0,7 | 26 | 0,77 |
| 1100 x 1800 | HCV500/600 | 1,4 / 0,7 | 20 | 0,63 |
| 1100 x 1800 | HCV500/350 | 1,4 / 0,7 | 11 | 0,42 |
| 1100 x 1900 | KR10B-600 | 1,0 | 19 | 0,66 |
| 1100 x 1900 | KR10B-500 | 1,0 | 16 | 0,58 |
| 1100 x 1900 | KR10B-400 | 1,0 | 12 | 0,49 |
| 1100 x 1900 | HCV500/800 | 1,4 / 0,7 | 25 | 0,80 |
| 1100 x 1900 | HCV500/600 | 1,4 / 0,7 | 19 | 0,66 |
| 1100 x 1900 | HCV500/350 | 1,4 / 0,7 | 11 | 0,45 |
| 1100 x 2000 | KR10B-600 | 1,0 | 18 | 0,69 |
| 1100 x 2000 | KR10B-500 | 1,0 | 15 | 0,61 |
| 1100 x 2000 | KR10B-400 | 1,0 | 12 | 0,52 |
| 1100 x 2000 | HCV500/800 | 1,4 / 0,7 | 24 | 0,84 |
| 1100 x 2000 | HCV500/600 | 1,4 / 0,7 | 18 | 0,69 |
| 1100 x 2000 | HCV500/350 | 1,4 / 0,7 | 10 | 0,48 |
| 1100 x 2100 | KR10B-600 | 1,0 | 17 | 0,73 |
| 1100 x 2100 | KR10B-500 | 1,0 | 14 | 0,64 |
| 1100 x 2100 | KR10B-400 | 1,0 | 11 | 0,55 |
| 1100 x 2100 | HCV500/800 | 1,4 / 0,7 | 23 | 0,89 |
| 1100 x 2100 | HCV500/600 | 1,4 / 0,7 | 17 | 0,73 |
| 1100 x 2100 | HCV500/350 | 1,4 / 0,7 | 10 | 0,42 |
| 1100 x 2200 | KR10B-600 | 1,0 | 16 | 0,76 |
| 1100 x 2200 | KR10B-500 | 1,0 | 13 | 0,66 |
| 1100 x 2200 | KR10B-400 | 1,0 | 11 | 0,57 |
| 1100 x 2200 | HCV500/800 | 1,4 / 0,7 | 21 | 0,93 |
| 1100 x 2200 | HCV500/600 | 1,4 / 0,7 | 16 | 0,75 |
| 1100 x 2200 | HCV500/350 | 1,4 / 0,7 | 9 | 0,44 |
| 1200 x 800 | KR10B-500 | 1,0 | 39 | 0,36 |
| 1200 x 800 | KR10B-400 | 1,0 | 31 | 0,31 |
| 1200 x 800 | HCV500/350 | 1,4 / 0,7 | 27 | 0,28 |
| 1200 x 900 | KR10B-500 | 1,0 | 34 | 0,38 |
| 1200 x 900 | KR10B-400 | 1,0 | 27 | 0,33 |
| 1200 x 900 | HCV500/350 | 1,4 / 0,7 | 24 | 0,29 |
| 1200 x 1000 | KR10B-500 | 1,0 | 31 | 0,41 |

1.2.5.2. technical specification - top- and bottom-opening smoke exhaust windows opening inwards with chain actuators

| WINDOW SIZE** | ACTUATOR* | POWER CONSUMPTION FOR 24 V- / 48 V-*** | OPENING ANGLE | ACTIVE AERODYNAMIC AREA [Aa] |
|---------------|-------------|--|---------------|------------------------------|
| B' x H' | | | | |
| [mm] | - | [A] | [°] | [m ²] |
| 1200 x 1000 | KR10B-400 | 1,0 | 24 | 0,34 |
| 1200 x 1000 | HCV500/350 | 1,4 / 0,7 | 21 | 0,30 |
| 1200 x 1100 | KR10-600 | 1,0 | 33 | 0,49 |
| 1200 x 1100 | KR10B-500 | 1,0 | 28 | 0,44 |
| 1200 x 1100 | KR10B-400 | 1,0 | 22 | 0,36 |
| 1200 x 1100 | HCV500/600 | 1,4 / 0,7 | 33 | 0,49 |
| 1200 x 1100 | HCV500/350 | 1,4 / 0,7 | 19 | 0,32 |
| 1200 x 1200 | KR10B-600 | 1,0 | 30 | 0,52 |
| 1200 x 1200 | KR10B-500 | 1,0 | 25 | 0,45 |
| 1200 x 1200 | KR10B-400 | 1,0 | 20 | 0,38 |
| 1200 x 1200 | HCV500/600 | 1,4 / 0,7 | 30 | 0,51 |
| 1200 x 1200 | HCV500/350 | 1,4 / 0,7 | 17 | 0,33 |
| 1200 x 1300 | KR10B-600 | 1,0 | 28 | 0,54 |
| 1200 x 1300 | KR10B-500 | 1,0 | 23 | 0,47 |
| 1200 x 1300 | KR10B-400 | 1,0 | 19 | 0,40 |
| 1200 x 1300 | HCV500/600 | 1,4 / 0,7 | 28 | 0,54 |
| 1200 x 1300 | HCV500/350 | 1,4 / 0,7 | 16 | 0,35 |
| 1200 x 1400 | KR10B-600 | 1,0 | 26 | 0,57 |
| 1200 x 1400 | KR10B-500 | 1,0 | 21 | 0,50 |
| 1200 x 1400 | KR10B-400 | 1,0 | 17 | 0,42 |
| 1200 x 1400 | HCV500/600 | 1,4 / 0,7 | 26 | 0,57 |
| 1200 x 1400 | HCV500/350 | 1,4 / 0,7 | 15 | 0,37 |
| 1200 x 1500 | KR10B-600 | 1,0 | 24 | 0,60 |
| 1200 x 1500 | KR10B-500 | 1,0 | 20 | 0,53 |
| 1200 x 1500 | KR10B-400 | 1,0 | 16 | 0,44 |
| 1200 x 1500 | HCV500/800 | 1,4 / 0,7 | 32 | 0,73 |
| 1200 x 1500 | HCV500/600 | 1,4 / 0,7 | 24 | 0,60 |
| 1200 x 1500 | HCV500/350 | 1,4 / 0,7 | 14 | 0,39 |
| 1200 x 1600 | KR10B-600 | 1,0 | 22 | 0,63 |
| 1200 x 1600 | KR10B-500 | 1,0 | 19 | 0,55 |
| 1200 x 1600 | KR10B-400 | 1,0 | 15 | 0,46 |
| 1200 x 1600 | HCV500/800 | 1,4 / 0,7 | 30 | 0,77 |
| 1200 x 1600 | HCV500/600 | 1,4 / 0,7 | 22 | 0,63 |
| 1200 x 1600 | HCV500/350 | 1,4 / 0,7 | 13 | 0,41 |
| 1200 x 1700 | KR10B-600 | 1,0 | 21 | 0,66 |
| 1200 x 1700 | KR10B-500 | 1,0 | 18 | 0,58 |
| 1200 x 1700 | KR10B-400 | 1,0 | 14 | 0,49 |
| 1200 x 1700 | HCV500/800 | 1,4 / 0,7 | 28 | 0,80 |
| 1200 x 1700 | HCV500/600 | 1,4 / 0,7 | 21 | 0,66 |
| 1200 x 1700 | HCV500/350 | 1,4 / 0,7 | 12 | 0,44 |
| 1200 x 1800 | KR10B-600 | 1,0 | 20 | 0,70 |
| 1200 x 1800 | KR10B-500 | 1,0 | 17 | 0,60 |
| 1200 x 1800 | KR10B-400 | 1,0 | 13 | 0,50 |
| 1200 x 1800 | HCV500/1000 | 1,4 / 0,7 | 33 | 0,95 |

| WINDOW SIZE** | ACTUATOR* | POWER CONSUMPTION FOR 24 V- / 48 V-*** | OPENING ANGLE | ACTIVE AERODYNAMIC AREA [Aa] |
|---------------|-------------|--|---------------|------------------------------|
| B' x H' | | | | |
| [mm] | - | [A] | [°] | [m ²] |
| 1200 x 1800 | HCV500/800 | 1,4 / 0,7 | 26 | 0,83 |
| 1200 x 1800 | HCV500/600 | 1,4 / 0,7 | 20 | 0,69 |
| 1200 x 1800 | HCV500/350 | 1,4 / 0,7 | 11 | 0,45 |
| 1200 x 1900 | KR10B-600 | 1,0 | 19 | 0,73 |
| 1200 x 1900 | KR10B-500 | 1,0 | 16 | 0,63 |
| 1200 x 1900 | KR10B-400 | 1,0 | 12 | 0,53 |
| 1200 x 1900 | HCV500/1000 | 1,4 / 0,7 | 31 | 1,00 |
| 1200 x 1900 | HCV500/800 | 1,4 / 0,7 | 25 | 0,87 |
| 1200 x 1900 | HCV500/600 | 1,4 / 0,7 | 19 | 0,72 |
| 1200 x 1900 | HCV500/350 | 1,4 / 0,7 | 11 | 0,47 |
| 1200 x 2000 | KR10B-600 | 1,0 | 18 | 0,75 |
| 1200 x 2000 | KR10B-500 | 1,0 | 15 | 0,66 |
| 1200 x 2000 | KR10B-400 | 1,0 | 12 | 0,56 |
| 1200 x 2000 | HCV500/1000 | 1,4 / 0,7 | 30 | 1,05 |
| 1200 x 2000 | HCV500/800 | 1,4 / 0,7 | 24 | 0,91 |
| 1200 x 2000 | HCV500/600 | 1,4 / 0,7 | 18 | 0,75 |
| 1200 x 2000 | HCV500/350 | 1,4 / 0,7 | 10 | 0,50 |
| 1200 x 2100 | KR10B-600 | 1,0 | 17 | 0,79 |
| 1200 x 2100 | KR10B-500 | 1,0 | 14 | 0,69 |
| 1200 x 2100 | KR10B-400 | 1,0 | 11 | 0,59 |
| 1200 x 2100 | HCV500/1000 | 1,4 / 0,7 | 28 | 1,09 |
| 1200 x 2100 | HCV500/800 | 1,4 / 0,7 | 23 | 0,95 |
| 1200 x 2100 | HCV500/600 | 1,4 / 0,7 | 17 | 0,78 |
| 1200 x 2100 | HCV500/350 | 1,4 / 0,7 | 10 | 0,33 |
| 1200 x 2200 | KR10B-600 | 1,0 | 16 | 0,82 |
| 1200 x 2200 | KR10B-500 | 1,0 | 13 | 0,72 |
| 1200 x 2200 | KR10B-400 | 1,0 | 11 | 0,62 |
| 1200 x 2200 | HCV500/1000 | 1,4 / 0,7 | 27 | 1,15 |
| 1200 x 2200 | HCV500/800 | 1,4 / 0,7 | 21 | 1,00 |
| 1200 x 2200 | HCV500/600 | 1,4 / 0,7 | 16 | 0,81 |
| 1200 x 2200 | HCV500/350 | 1,4 / 0,7 | 9 | 0,34 |
| 1300 x 800 | KR10B-500 | 1,0 | 39 | 0,38 |
| 1300 x 800 | KR10B-400 | 1,0 | 31 | 0,33 |
| 1300 x 800 | HCV500/350 | 1,4 / 0,7 | 27 | 0,30 |
| 1300 x 900 | KR10B-500 | 1,0 | 34 | 0,41 |
| 1300 x 900 | KR10B-400 | 1,0 | 27 | 0,36 |
| 1300 x 900 | HCV500/350 | 1,4 / 0,7 | 24 | 0,31 |
| 1300 x 1000 | KR10B-500 | 1,0 | 31 | 0,44 |
| 1300 x 1000 | KR10B-400 | 1,0 | 24 | 0,36 |
| 1300 x 1000 | HCV500/350 | 1,4 / 0,7 | 21 | 0,32 |
| 1300 x 1100 | KR10B-500 | 1,0 | 28 | 0,46 |
| 1300 x 1100 | KR10B-400 | 1,0 | 22 | 0,38 |
| 1300 x 1100 | HCV500/600 | 1,4 / 0,7 | 33 | 0,53 |
| 1300 x 1100 | HCV500/350 | 1,4 / 0,7 | 19 | 0,34 |

1.2.5.2. technical specification - top- and bottom-opening smoke exhaust windows opening inwards with chain actuators

| WINDOW SIZE** | ACTUATOR* | POWER CONSUMPTION FOR 24 V- / 48 V-*** | OPENING ANGLE | ACTIVE AERODYNAMIC AREA [Aa] |
|---------------|-------------|--|---------------|------------------------------|
| B' x H' | | | | |
| [mm] | - | [A] | [°] | [m ²] |
| 1300 x 1200 | KR10B-500 | 1,0 | 25 | 0,49 |
| 1300 x 1200 | KR10B-400 | 1,0 | 20 | 0,41 |
| 1300 x 1200 | HCV500/600 | 1,4 / 0,7 | 30 | 0,56 |
| 1300 x 1200 | HCV500/350 | 1,4 / 0,7 | 17 | 0,36 |
| 1300 x 1300 | KR10B-500 | 1,0 | 23 | 0,51 |
| 1300 x 1300 | KR10B-400 | 1,0 | 19 | 0,43 |
| 1300 x 1300 | HCV500/600 | 1,4 / 0,7 | 28 | 0,59 |
| 1300 x 1300 | HCV500/350 | 1,4 / 0,7 | 16 | 0,38 |
| 1300 x 1400 | KR10B-500 | 1,0 | 21 | 0,54 |
| 1300 x 1400 | KR10B-400 | 1,0 | 17 | 0,45 |
| 1300 x 1400 | HCV500/600 | 1,4 / 0,7 | 26 | 0,61 |
| 1300 x 1400 | HCV500/350 | 1,4 / 0,7 | 15 | 0,40 |
| 1300 x 1500 | KR10B-500 | 1,0 | 20 | 0,56 |
| 1300 x 1500 | KR10B-400 | 1,0 | 16 | 0,47 |
| 1300 x 1500 | HCV500/800 | 1,4 / 0,7 | 32 | 0,79 |
| 1300 x 1500 | HCV500/600 | 1,4 / 0,7 | 24 | 0,64 |
| 1300 x 1500 | HCV500/350 | 1,4 / 0,7 | 14 | 0,42 |
| 1300 x 1600 | KR10B-500 | 1,0 | 19 | 0,59 |
| 1300 x 1600 | KR10B-400 | 1,0 | 15 | 0,49 |
| 1300 x 1600 | HCV500/800 | 1,4 / 0,7 | 30 | 0,84 |
| 1300 x 1600 | HCV500/600 | 1,4 / 0,7 | 22 | 0,67 |
| 1300 x 1600 | HCV500/350 | 1,4 / 0,7 | 13 | 0,43 |
| 1300 x 1700 | KR10B-600 | 1,0 | 21 | 0,71 |
| 1300 x 1700 | KR10B-500 | 1,0 | 18 | 0,61 |
| 1300 x 1700 | KR10B-400 | 1,0 | 14 | 0,51 |
| 1300 x 1700 | HCV500/800 | 1,4 / 0,7 | 28 | 0,87 |
| 1300 x 1700 | HCV500/600 | 1,4 / 0,7 | 21 | 0,71 |
| 1300 x 1700 | HCV500/350 | 1,4 / 0,7 | 12 | 0,46 |
| 1300 x 1800 | KR10B-600 | 1,0 | 20 | 0,74 |
| 1300 x 1800 | KR10B-500 | 1,0 | 17 | 0,64 |
| 1300 x 1800 | KR10B-400 | 1,0 | 13 | 0,54 |
| 1300 x 1800 | HCV500/1000 | 1,4 / 0,7 | 33 | 1,04 |
| 1300 x 1800 | HCV500/800 | 1,4 / 0,7 | 26 | 0,90 |
| 1300 x 1800 | HCV500/600 | 1,4 / 0,7 | 20 | 0,74 |
| 1300 x 1800 | HCV500/350 | 1,4 / 0,7 | 11 | 0,49 |
| 1300 x 1900 | KR10B-600 | 1,0 | 19 | 0,77 |
| 1300 x 1900 | KR10B-500 | 1,0 | 16 | 0,67 |
| 1300 x 1900 | KR10B-400 | 1,0 | 12 | 0,57 |
| 1300 x 1900 | HCV500/1000 | 1,4 / 0,7 | 31 | 1,09 |
| 1300 x 1900 | HCV500/800 | 1,4 / 0,7 | 25 | 0,94 |
| 1300 x 1900 | HCV500/600 | 1,4 / 0,7 | 19 | 0,77 |
| 1300 x 1900 | HCV500/350 | 1,4 / 0,7 | 11 | 0,52 |
| 1300 x 2000 | KR10B-600 | 1,0 | 18 | 0,81 |
| 1300 x 2000 | KR10B-500 | 1,0 | 15 | 0,70 |

| WINDOW SIZE** | ACTUATOR* | POWER CONSUMPTION FOR 24 V- / 48 V-*** | OPENING ANGLE | ACTIVE AERODYNAMIC AREA [Aa] |
|---------------|-------------|--|---------------|------------------------------|
| B' x H' | | | | |
| [mm] | - | [A] | [°] | [m ²] |
| 1300 x 2000 | KR10B-400 | 1,0 | 12 | 0,60 |
| 1300 x 2000 | HCV500/1000 | 1,4 / 0,7 | 30 | 1,15 |
| 1300 x 2000 | HCV500/800 | 1,4 / 0,7 | 24 | 0,98 |
| 1300 x 2000 | HCV500/600 | 1,4 / 0,7 | 18 | 0,80 |
| 1300 x 2000 | HCV500/350 | 1,4 / 0,7 | 10 | 0,55 |
| 1300 x 2100 | KR10B-600 | 1,0 | 17 | 0,85 |
| 1300 x 2100 | KR10B-500 | 1,0 | 14 | 0,75 |
| 1300 x 2100 | KR10B-400 | 1,0 | 11 | 0,64 |
| 1300 x 2100 | HCV500/1000 | 1,4 / 0,7 | 28 | 1,19 |
| 1300 x 2100 | HCV500/800 | 1,4 / 0,7 | 23 | 1,04 |
| 1300 x 2100 | HCV500/600 | 1,4 / 0,7 | 17 | 0,85 |
| 1300 x 2100 | HCV500/350 | 1,4 / 0,7 | 10 | 0,36 |
| 1300 x 2200 | KR10B-600 | 1,0 | 16 | 0,89 |
| 1300 x 2200 | KR10B-500 | 1,0 | 13 | 0,78 |
| 1300 x 2200 | KR10B-400 | 1,0 | 11 | 0,68 |
| 1300 x 2200 | HCV500/1000 | 1,4 / 0,7 | 27 | 1,24 |
| 1300 x 2200 | HCV500/800 | 1,4 / 0,7 | 21 | 1,09 |
| 1300 x 2200 | HCV500/600 | 1,4 / 0,7 | 16 | 0,89 |
| 1300 x 2200 | HCV500/350 | 1,4 / 0,7 | 9 | 0,37 |
| 1400 x 800 | KR10B-400 | 1,0 | 31 | 0,36 |
| 1400 x 800 | HCV500/350 | 1,4 / 0,7 | 27 | 0,32 |
| 1400 x 900 | KR10B-500 | 1,0 | 34 | 0,44 |
| 1400 x 900 | KR10B-400 | 1,0 | 27 | 0,38 |
| 1400 x 900 | HCV500/350 | 1,4 / 0,7 | 24 | 0,33 |
| 1400x 1000 | KR10B-500 | 1,0 | 31 | 0,48 |
| 1400x 1000 | KR10B-400 | 1,0 | 24 | 0,40 |
| 1400x 1000 | HCV500/350 | 1,4 / 0,7 | 21 | 0,35 |
| 1400 x 1100 | KR10B-500 | 1,0 | 28 | 0,50 |
| 1400 x 1100 | KR10B-400 | 1,0 | 22 | 0,42 |
| 1400 x 1100 | HCV500/600 | 1,4 / 0,7 | 33 | 0,57 |
| 1400 x 1100 | HCV500/350 | 1,4 / 0,7 | 19 | 0,37 |
| 1400 x 1200 | KR10B-500 | 1,0 | 25 | 0,53 |
| 1400 x 1200 | KR10B-400 | 1,0 | 20 | 0,44 |
| 1400 x 1200 | HCV500/600 | 1,4 / 0,7 | 30 | 0,61 |
| 1400 x 1200 | HCV500/350 | 1,4 / 0,7 | 17 | 0,39 |
| 1400 x 1300 | KR10B-500 | 1,0 | 23 | 0,55 |
| 1400 x 1300 | KR10B-400 | 1,0 | 19 | 0,46 |
| 1400 x 1300 | HCV500/600 | 1,4 / 0,7 | 28 | 0,64 |
| 1400 x 1300 | HCV500/350 | 1,4 / 0,7 | 16 | 0,41 |
| 1400 x 1400 | KR10B-500 | 1,0 | 21 | 0,58 |
| 1400 x 1400 | KR10B-400 | 1,0 | 17 | 0,48 |
| 1400 x 1400 | HCV500/600 | 1,4 / 0,7 | 26 | 0,67 |
| 1400 x 1400 | HCV500/350 | 1,4 / 0,7 | 15 | 0,43 |
| 1400 x 1500 | KR10B-500 | 1,0 | 20 | 0,61 |

1.2.5.2. technical specification - top- and bottom-opening smoke exhaust windows opening inwards with chain actuators

| WINDOW SIZE** | ACTUATOR* | POWER CONSUMPTION FOR 24 V- / 48 V-*** | OPENING ANGLE | ACTIVE AERODYNAMIC AREA [Aa] |
|---------------|-------------|--|---------------|------------------------------|
| B' x H' | | | | |
| [mm] | - | [A] | [°] | [m ²] |
| 1400 x 1500 | KR10B-400 | 1,0 | 16 | 0,50 |
| 1400 x 1500 | HCV500/800 | 1,4 / 0,7 | 32 | 0,85 |
| 1400 x 1500 | HCV500/600 | 1,4 / 0,7 | 24 | 0,70 |
| 1400 x 1500 | HCV500/350 | 1,4 / 0,7 | 14 | 0,44 |
| 1400 x 1600 | KR10B-500 | 1,0 | 19 | 0,64 |
| 1400 x 1600 | KR10B-400 | 1,0 | 15 | 0,53 |
| 1400 x 1600 | HCV500/800 | 1,4 / 0,7 | 30 | 0,91 |
| 1400 x 1600 | HCV500/600 | 1,4 / 0,7 | 22 | 0,73 |
| 1400 x 1600 | HCV500/350 | 1,4 / 0,7 | 13 | 0,47 |
| 1400 x 1700 | KR10B-500 | 1,0 | 18 | 0,66 |
| 1400 x 1700 | KR10B-400 | 1,0 | 14 | 0,56 |
| 1400 x 1700 | HCV500/800 | 1,4 / 0,7 | 28 | 0,94 |
| 1400 x 1700 | HCV500/600 | 1,4 / 0,7 | 21 | 0,76 |
| 1400 x 1700 | HCV500/350 | 1,4 / 0,7 | 12 | 0,50 |
| 1400 x 1800 | KR10B-500 | 1,0 | 17 | 0,70 |
| 1400 x 1800 | KR10B-400 | 1,0 | 13 | 0,59 |
| 1400 x 1800 | HCV500/1000 | 1,4 / 0,7 | 33 | 1,11 |
| 1400 x 1800 | HCV500/800 | 1,4 / 0,7 | 26 | 0,97 |
| 1400 x 1800 | HCV500/600 | 1,4 / 0,7 | 20 | 0,80 |
| 1400 x 1800 | HCV500/350 | 1,4 / 0,7 | 11 | 0,53 |
| 1400 x 1900 | KR10B-500 | 1,0 | 16 | 0,73 |
| 1400 x 1900 | KR10B-400 | 1,0 | 12 | 0,62 |
| 1400 x 1900 | HCV500/1000 | 1,4 / 0,7 | 31 | 1,16 |
| 1400 x 1900 | HCV500/800 | 1,4 / 0,7 | 25 | 1,01 |
| 1400 x 1900 | HCV500/600 | 1,4 / 0,7 | 19 | 0,83 |
| 1400 x 1900 | HCV500/350 | 1,4 / 0,7 | 11 | 0,56 |
| 1400 x 2000 | KR10B-500 | 1,0 | 15 | 0,75 |
| 1400 x 2000 | KR10B-400 | 1,0 | 12 | 0,63 |
| 1400 x 2000 | HCV500/1000 | 1,4 / 0,7 | 30 | 1,24 |
| 1400 x 2000 | HCV500/800 | 1,4 / 0,7 | 24 | 1,06 |
| 1400 x 2000 | HCV500/600 | 1,4 / 0,7 | 18 | 0,86 |
| 1400 x 2000 | HCV500/350 | 1,4 / 0,7 | 10 | 0,57 |
| 1400 x 2100 | KR10B-500 | 1,0 | 14 | 0,78 |
| 1400 x 2100 | KR10B-400 | 1,0 | 11 | 0,67 |
| 1400 x 2100 | HCV500/1000 | 1,4 / 0,7 | 28 | 1,28 |
| 1400 x 2100 | HCV500/800 | 1,4 / 0,7 | 23 | 1,11 |
| 1400 x 2100 | HCV500/600 | 1,4 / 0,7 | 17 | 0,90 |
| 1400 x 2100 | HCV500/350 | 1,4 / 0,7 | 10 | 0,39 |
| 1400 x 2200 | KR10B-500 | 1,0 | 13 | 0,82 |
| 1400 x 2200 | KR10B-400 | 1,0 | 11 | 0,71 |
| 1400 x 2200 | HCV500/1000 | 1,4 / 0,7 | 27 | 1,33 |
| 1400 x 2200 | HCV500/800 | 1,4 / 0,7 | 21 | 1,15 |
| 1400 x 2200 | HCV500/600 | 1,4 / 0,7 | 16 | 0,93 |
| 1400 x 2200 | HCV500/350 | 1,4 / 0,7 | 9 | 0,41 |

| WINDOW SIZE** | ACTUATOR* | POWER CONSUMPTION FOR 24 V- / 48 V-*** | OPENING ANGLE | ACTIVE AERODYNAMIC AREA [Aa] |
|---------------|-------------|--|---------------|------------------------------|
| B' x H' | | | | |
| [mm] | - | [A] | [°] | [m ²] |
| 1500 x 800 | KR10B-400 | 1,0 | 31 | 0,39 |
| 1500 x 800 | HCV500/350 | 1,4 / 0,7 | 27 | 0,35 |
| 1500 x 900 | KR10B-400 | 1,0 | 27 | 0,41 |
| 1500 x 900 | HCV500/350 | 1,4 / 0,7 | 24 | 0,36 |
| 1500 x 1000 | KR10B-400 | 1,0 | 24 | 0,43 |
| 1500 x 1000 | HCV500/350 | 1,4 / 0,7 | 21 | 0,38 |
| 1500 x 1100 | KR10B-400 | 1,0 | 22 | 0,45 |
| 1500 x 1100 | HCV500/600 | 1,4 / 0,7 | 33 | 0,61 |
| 1500 x 1100 | HCV500/350 | 1,4 / 0,7 | 19 | 0,40 |
| 1500 x 1200 | KR10B-500 | 1,0 | 25 | 0,57 |
| 1500 x 1200 | KR10B-400 | 1,0 | 20 | 0,47 |
| 1500 x 1200 | HCV500/600 | 1,4 / 0,7 | 30 | 0,66 |
| 1500 x 1200 | HCV500/350 | 1,4 / 0,7 | 17 | 0,42 |
| 1500 x 1300 | KR10B-500 | 1,0 | 23 | 0,60 |
| 1500 x 1300 | KR10B-400 | 1,0 | 19 | 0,50 |
| 1500 x 1300 | HCV500/600 | 1,4 / 0,7 | 28 | 0,69 |
| 1500 x 1300 | HCV500/350 | 1,4 / 0,7 | 16 | 0,44 |
| 1500 x 1400 | KR10B-500 | 1,0 | 21 | 0,62 |
| 1500 x 1400 | KR10B-400 | 1,0 | 17 | 0,52 |
| 1500 x 1400 | HCV500/600 | 1,4 / 0,7 | 26 | 0,71 |
| 1500 x 1400 | HCV500/350 | 1,4 / 0,7 | 15 | 0,45 |
| 1500 x 1500 | KR10B-500 | 1,0 | 20 | 0,64 |
| 1500 x 1500 | KR10B-400 | 1,0 | 16 | 0,53 |
| 1500 x 1500 | HCV500/800 | 1,4 / 0,7 | 32 | 0,91 |
| 1500 x 1500 | HCV500/600 | 1,4 / 0,7 | 24 | 0,73 |
| 1500 x 1500 | HCV500/350 | 1,4 / 0,7 | 14 | 0,47 |
| 1500 x 1600 | KR10B-500 | 1,0 | 19 | 0,67 |
| 1500 x 1600 | KR10B-400 | 1,0 | 15 | 0,56 |
| 1500 x 1600 | HCV500/800 | 1,4 / 0,7 | 30 | 0,96 |
| 1500 x 1600 | HCV500/600 | 1,4 / 0,7 | 22 | 0,77 |
| 1500 x 1600 | HCV500/350 | 1,4 / 0,7 | 13 | 0,50 |
| 1500 x 1700 | KR10B-500 | 1,0 | 18 | 0,70 |
| 1500 x 1700 | KR10B-400 | 1,0 | 14 | 0,59 |
| 1500 x 1700 | HCV500/800 | 1,4 / 0,7 | 28 | 0,99 |
| 1500 x 1700 | HCV500/600 | 1,4 / 0,7 | 21 | 0,80 |
| 1500 x 1700 | HCV500/350 | 1,4 / 0,7 | 12 | 0,53 |
| 1500 x 1800 | KR10B-500 | 1,0 | 17 | 0,73 |
| 1500 x 1800 | KR10B-400 | 1,0 | 13 | 0,61 |
| 1500 x 1800 | HCV500/1000 | 1,4 / 0,7 | 33 | 1,19 |
| 1500 x 1800 | HCV500/800 | 1,4 / 0,7 | 26 | 1,03 |
| 1500 x 1800 | HCV500/600 | 1,4 / 0,7 | 20 | 0,84 |
| 1500 x 1800 | HCV500/350 | 1,4 / 0,7 | 11 | 0,54 |
| 1500 x 1900 | KR10B-500 | 1,0 | 16 | 0,76 |
| 1500 x 1900 | KR10B-400 | 1,0 | 12 | 0,64 |

1.2.5.2. technical specification - top- and bottom-opening smoke exhaust windows opening inwards with chain actuators

| WINDOW SIZE** | ACTUATOR* | POWER CONSUMPTION FOR 24 V- / 48 V-*** | OPENING ANGLE | ACTIVE AERODYNAMIC AREA [Aa] |
|---------------|-------------|--|---------------|------------------------------|
| B' x H' | | | | |
| [mm] | - | [A] | [°] | [m ²] |
| 1500 x 1900 | HCV500/1000 | 1,4 / 0,7 | 31 | 1,25 |
| 1500 x 1900 | HCV500/800 | 1,4 / 0,7 | 25 | 1,07 |
| 1500 x 1900 | HCV500/600 | 1,4 / 0,7 | 19 | 0,87 |
| 1500 x 1900 | HCV500/350 | 1,4 / 0,7 | 11 | 0,58 |
| 1500 x 2000 | KR10B-500 | 1,0 | 15 | 0,81 |
| 1500 x 2000 | KR10B-400 | 1,0 | 12 | 0,68 |
| 1500 x 2000 | HCV500/1000 | 1,4 / 0,7 | 30 | 1,31 |
| 1500 x 2000 | HCV500/800 | 1,4 / 0,7 | 24 | 1,13 |
| 1500 x 2000 | HCV500/600 | 1,4 / 0,7 | 18 | 0,93 |
| 1500 x 2000 | HCV500/350 | 1,4 / 0,7 | 10 | 0,61 |
| 1500 x 2100 | KR10B-500 | 1,0 | 14 | 0,84 |
| 1500 x 2100 | KR10B-400 | 1,0 | 11 | 0,72 |
| 1500 x 2100 | HCV500/1000 | 1,4 / 0,7 | 28 | 1,36 |
| 1500 x 2100 | HCV500/800 | 1,4 / 0,7 | 23 | 1,18 |
| 1500 x 2100 | HCV500/600 | 1,4 / 0,7 | 17 | 0,97 |
| 1500 x 2100 | HCV500/350 | 1,4 / 0,7 | 10 | 0,42 |
| 1500 x 2200 | KR10B-500 | 1,0 | 13 | 0,89 |
| 1500 x 2200 | KR10B-400 | 1,0 | 11 | 0,76 |
| 1500 x 2200 | HCV500/1000 | 1,4 / 0,7 | 27 | 1,42 |
| 1500 x 2200 | HCV500/800 | 1,4 / 0,7 | 21 | 1,24 |
| 1500 x 2200 | HCV500/600 | 1,4 / 0,7 | 16 | 1,01 |
| 1500 x 2200 | HCV500/350 | 1,4 / 0,7 | 9 | 0,44 |
| 1600 x 800 | KR10B-400 | 1,0 | 31 | 0,41 |
| 1600 x 800 | HCV500/350 | 1,4 / 0,7 | 27 | 0,36 |
| 1600 x 900 | KR10B-400 | 1,0 | 27 | 0,44 |
| 1600 x 900 | HCV500/350 | 1,4 / 0,7 | 24 | 0,38 |
| 1600 x 1000 | KR10B-400 | 1,0 | 24 | 0,46 |
| 1600 x 1000 | HCV500/350 | 1,4 / 0,7 | 21 | 0,40 |
| 1600 x 1100 | KR10B-400 | 1,0 | 22 | 0,48 |
| 1600 x 1100 | HCV500/600 | 1,4 / 0,7 | 33 | 0,66 |
| 1600 x 1100 | HCV500/350 | 1,4 / 0,7 | 19 | 0,43 |
| 1600 x 1200 | KR10B-400 | 1,0 | 20 | 0,51 |
| 1600 x 1200 | HCV500/600 | 1,4 / 0,7 | 30 | 0,69 |
| 1600 x 1200 | HCV500/350 | 1,4 / 0,7 | 17 | 0,45 |
| 1600 x 1300 | KR10B-400 | 1,0 | 19 | 0,52 |
| 1600 x 1300 | HCV500/600 | 1,4 / 0,7 | 28 | 0,72 |
| 1600 x 1300 | HCV500/350 | 1,4 / 0,7 | 16 | 0,45 |
| 1600 x 1400 | KR10B-400 | 1,0 | 17 | 0,54 |
| 1600 x 1400 | HCV500/600 | 1,4 / 0,7 | 26 | 0,75 |
| 1600 x 1400 | HCV500/350 | 1,4 / 0,7 | 15 | 0,48 |
| 1600 x 1500 | KR10B-400 | 1,0 | 16 | 0,57 |
| 1600 x 1500 | HCV500/800 | 1,4 / 0,7 | 32 | 0,97 |
| 1600 x 1500 | HCV500/600 | 1,4 / 0,7 | 24 | 0,78 |
| 1600 x 1500 | HCV500/350 | 1,4 / 0,7 | 14 | 0,51 |

| WINDOW SIZE** | ACTUATOR* | POWER CONSUMPTION FOR 24 V- / 48 V-*** | OPENING ANGLE | ACTIVE AERODYNAMIC AREA [Aa] |
|---------------|-------------|--|---------------|------------------------------|
| B' x H' | | | | |
| [mm] | - | [A] | [°] | [m ²] |
| 1600 x 1600 | KR10B-400 | 1,0 | 15 | 0,60 |
| 1600 x 1600 | HCV500/800 | 1,4 / 0,7 | 30 | 1,03 |
| 1600 x 1600 | HCV500/600 | 1,4 / 0,7 | 22 | 0,82 |
| 1600 x 1600 | HCV500/350 | 1,4 / 0,7 | 13 | 0,54 |
| 1600 x 1700 | KR10B-400 | 1,0 | 14 | 0,62 |
| 1600 x 1700 | HCV500/800 | 1,4 / 0,7 | 28 | 1,06 |
| 1600 x 1700 | HCV500/600 | 1,4 / 0,7 | 21 | 0,86 |
| 1600 x 1700 | HCV500/350 | 1,4 / 0,7 | 12 | 0,55 |
| 1600 x 1800 | KR10B-500 | 1,0 | 17 | 0,77 |
| 1600 x 1800 | KR10B-400 | 1,0 | 13 | 0,65 |
| 1600 x 1800 | HCV500/1000 | 1,4 / 0,7 | 33 | 1,27 |
| 1600 x 1800 | HCV500/800 | 1,4 / 0,7 | 26 | 1,10 |
| 1600 x 1800 | HCV500/600 | 1,4 / 0,7 | 20 | 0,90 |
| 1600 x 1800 | HCV500/350 | 1,4 / 0,7 | 11 | 0,58 |
| 1600 x 1900 | KR10B-500 | 1,0 | 16 | 0,81 |
| 1600 x 1900 | KR10B-400 | 1,0 | 12 | 0,69 |
| 1600 x 1900 | HCV500/1000 | 1,4 / 0,7 | 31 | 1,34 |
| 1600 x 1900 | HCV500/800 | 1,4 / 0,7 | 25 | 1,15 |
| 1600 x 1900 | HCV500/600 | 1,4 / 0,7 | 19 | 0,93 |
| 1600 x 1900 | HCV500/350 | 1,4 / 0,7 | 11 | 0,62 |
| 1600 x 2000 | KR10B-500 | 1,0 | 15 | 0,85 |
| 1600 x 2000 | KR10B-400 | 1,0 | 12 | 0,73 |
| 1600 x 2000 | HCV500/1000 | 1,4 / 0,7 | 30 | 1,40 |
| 1600 x 2000 | HCV500/800 | 1,4 / 0,7 | 24 | 1,20 |
| 1600 x 2000 | HCV500/600 | 1,4 / 0,7 | 18 | 0,97 |
| 1600 x 2000 | HCV500/350 | 1,4 / 0,7 | 10 | 0,66 |
| 1600 x 2100 | KR10B-500 | 1,0 | 14 | 0,89 |
| 1600 x 2100 | KR10B-400 | 1,0 | 11 | 0,77 |
| 1600 x 2100 | HCV500/1000 | 1,4 / 0,7 | 28 | 1,45 |
| 1600 x 2100 | HCV500/800 | 1,4 / 0,7 | 23 | 1,25 |
| 1600 x 2100 | HCV500/600 | 1,4 / 0,7 | 17 | 1,02 |
| 1600 x 2100 | HCV500/350 | 1,4 / 0,7 | 10 | 0,45 |
| 1600 x 2200 | KR10B-500 | 1,0 | 13 | 0,92 |
| 1600 x 2200 | KR10B-400 | 1,0 | 11 | 0,78 |
| 1600 x 2200 | HCV500/1000 | 1,4 / 0,7 | 27 | 1,51 |
| 1600 x 2200 | HCV500/800 | 1,4 / 0,7 | 21 | 1,30 |
| 1600 x 2200 | HCV500/600 | 1,4 / 0,7 | 16 | 1,05 |
| 1600 x 2200 | HCV500/350 | 1,4 / 0,7 | 9 | 0,47 |
| 1700 x 800 | KR10B-400 | 1,0 | 31 | 0,44 |
| 1700 x 800 | HCV500/350 | 2x 1,4 / 2x 0,7 | 27 | 0,39 |
| 1700 x 900 | KR10B-400 | 1,0 | 27 | 0,47 |
| 1700 x 900 | HCV500/350 | 2x 1,4 / 2x 0,7 | 24 | 0,41 |
| 1700 x 1000 | KR10B-400 | 1,0 | 24 | 0,49 |
| 1700 x 1000 | HCV500/350 | 2x 1,4 / 2x 0,7 | 21 | 0,43 |

1.2.5.2. technical specification - top- and bottom-opening smoke exhaust windows opening inwards with chain actuators

| WINDOW SIZE** | ACTUATOR* | POWER CONSUMPTION FOR 24 V- / 48 V-*** | OPENING ANGLE | ACTIVE AERODYNAMIC AREA [Aa] |
|---------------|-------------|--|---------------|------------------------------|
| B' x H' | | | | |
| [mm] | - | [A] | [°] | [m ²] |
| 1700 x 1100 | KR10B-400 | 1,0 | 22 | 0,50 |
| 1700 x 1100 | HCV500/600 | 2x 1,4 / 2x 0,7 | 33 | 0,69 |
| 1700 x 1100 | HCV500/350 | 2x 1,4 / 2x 0,7 | 19 | 0,44 |
| 1700 x 1200 | KR10B-400 | 1,0 | 20 | 0,53 |
| 1700 x 1200 | HCV500/600 | 2x 1,4 / 2x 0,7 | 30 | 0,74 |
| 1700 x 1200 | HCV500/350 | 2x 1,4 / 2x 0,7 | 17 | 0,46 |
| 1700 x 1300 | KR10B-400 | 1,0 | 19 | 0,55 |
| 1700 x 1300 | HCV500/600 | 2x 1,4 / 2x 0,7 | 28 | 0,77 |
| 1700 x 1300 | HCV500/350 | 2x 1,4 / 2x 0,7 | 16 | 0,48 |
| 1700 x 1400 | KR10B-400 | 1,0 | 17 | 0,58 |
| 1700 x 1400 | HCV500/600 | 2x 1,4 / 2x 0,7 | 26 | 0,80 |
| 1700 x 1400 | HCV500/350 | 2x 1,4 / 2x 0,7 | 15 | 0,51 |
| 1700 x 1500 | KR10B-400 | 1,0 | 16 | 0,61 |
| 1700 x 1500 | HCV500/800 | 1,4 / 0,7 | 32 | 1,03 |
| 1700 x 1500 | HCV500/600 | 2x 1,4 / 2x 0,7 | 24 | 0,84 |
| 1700 x 1500 | HCV500/350 | 2x 1,4 / 2x 0,7 | 14 | 0,54 |
| 1700 x 1600 | KR10B-400 | 1,0 | 15 | 0,63 |
| 1700 x 1600 | HCV500/800 | 1,4 / 0,7 | 30 | 1,09 |
| 1700 x 1600 | HCV500/600 | 2x 1,4 / 2x 0,7 | 22 | 0,88 |
| 1700 x 1600 | HCV500/350 | 2x 1,4 / 2x 0,7 | 13 | 0,55 |
| 1700 x 1700 | KR10B-400 | 1,0 | 14 | 0,66 |
| 1700 x 1700 | HCV500/800 | 1,4 / 0,7 | 28 | 1,13 |
| 1700 x 1700 | HCV500/600 | 2x 1,4 / 2x 0,7 | 21 | 0,91 |
| 1700 x 1700 | HCV500/350 | 2x 1,4 / 2x 0,7 | 12 | 0,58 |
| 1700 x 1800 | KR10B-400 | 1,0 | 13 | 0,69 |
| 1700 x 1800 | HCV500/1000 | 1,4 / 0,7 | 33 | 1,34 |
| 1700 x 1800 | HCV500/800 | 1,4 / 0,7 | 26 | 1,16 |
| 1700 x 1800 | HCV500/600 | 2x 1,4 / 2x 0,7 | 20 | 0,96 |
| 1700 x 1800 | HCV500/350 | 2x 1,4 / 2x 0,7 | 11 | 0,62 |
| 1700 x 1900 | KR10B-400 | 1,0 | 12 | 0,73 |
| 1700 x 1900 | HCV500/1000 | 1,4 / 0,7 | 31 | 1,40 |
| 1700 x 1900 | HCV500/800 | 1,4 / 0,7 | 25 | 1,21 |
| 1700 x 1900 | HCV500/600 | 2x 1,4 / 2x 0,7 | 19 | 1,00 |
| 1700 x 1900 | HCV500/350 | 2x 1,4 / 2x 0,7 | 11 | 0,66 |
| 1700 x 2000 | KR10B-400 | 1,0 | 12 | 0,75 |
| 1700 x 2000 | HCV500/1000 | 1,4 / 0,7 | 30 | 1,47 |
| 1700 x 2000 | HCV500/800 | 1,4 / 0,7 | 24 | 1,27 |
| 1700 x 2000 | HCV500/600 | 2x 1,4 / 2x 0,7 | 18 | 1,03 |
| 1700 x 2000 | HCV500/350 | 2x 1,4 / 2x 0,7 | 10 | 0,67 |
| 1800 x 800 | KR10B-500 | 2x 1,0 | 39 | 0,54 |
| 1800 x 800 | KR10B-400 | 2x 1,0 | 31 | 0,47 |
| 1800 x 800 | HCV500/350 | 2x 1,4 / 2x 0,7 | 27 | 0,41 |
| 1800 x 900 | KR10B-500 | 2x 1,0 | 34 | 0,58 |
| 1800 x 900 | KR10B-400 | 2x 1,0 | 27 | 0,49 |

| WINDOW SIZE** | ACTUATOR* | POWER CONSUMPTION FOR 24 V- / 48 V-*** | OPENING ANGLE | ACTIVE AERODYNAMIC AREA [Aa] |
|---------------|-------------|--|---------------|------------------------------|
| B' x H' | | | | |
| [mm] | - | [A] | [°] | [m ²] |
| 1800 x 900 | HCV500/350 | 2x 1,4 / 2x 0,7 | 24 | 0,44 |
| 1800 x 1000 | KR10B-500 | 2x 1,0 | 31 | 0,63 |
| 1800 x 1000 | KR10B-400 | 2x 1,0 | 24 | 0,52 |
| 1800 x 1000 | HCV500/350 | 2x 1,4 / 2x 0,7 | 21 | 0,46 |
| 1800 x 1100 | KR10B-500 | 2x 1,0 | 28 | 0,64 |
| 1800 x 1100 | KR10B-400 | 2x 1,0 | 22 | 0,53 |
| 1800 x 1100 | HCV500/600 | 2x 1,4 / 2x 0,7 | 33 | 0,73 |
| 1800 x 1100 | HCV500/350 | 2x 1,4 / 2x 0,7 | 19 | 0,47 |
| 1800 x 1200 | KR10B-500 | 2x 1,0 | 25 | 0,67 |
| 1800 x 1200 | KR10B-400 | 2x 1,0 | 20 | 0,56 |
| 1800 x 1200 | HCV500/600 | 2x 1,4 / 2x 0,7 | 30 | 0,78 |
| 1800 x 1200 | HCV500/350 | 2x 1,4 / 2x 0,7 | 17 | 0,49 |
| 1800 x 1300 | KR10B-500 | 2x 1,0 | 23 | 0,70 |
| 1800 x 1300 | KR10B-400 | 2x 1,0 | 19 | 0,58 |
| 1800 x 1300 | HCV500/600 | 2x 1,4 / 2x 0,7 | 28 | 0,82 |
| 1800 x 1300 | HCV500/350 | 2x 1,4 / 2x 0,7 | 16 | 0,51 |
| 1800 x 1400 | KR10B-500 | 2x 1,0 | 21 | 0,74 |
| 1800 x 1400 | KR10B-400 | 2x 1,0 | 17 | 0,61 |
| 1800 x 1400 | HCV500/600 | 2x 1,4 / 2x 0,7 | 26 | 0,85 |
| 1800 x 1400 | HCV500/350 | 2x 1,4 / 2x 0,7 | 15 | 0,54 |
| 1800 x 1500 | KR10B-500 | 2x 1,0 | 20 | 0,78 |
| 1800 x 1500 | KR10B-400 | 2x 1,0 | 16 | 0,64 |
| 1800 x 1500 | HCV500/800 | 1,4 / 0,7 | 32 | 1,08 |
| 1800 x 1500 | HCV500/600 | 2x 1,4 / 2x 0,7 | 24 | 0,88 |
| 1800 x 1500 | HCV500/350 | 2x 1,4 / 2x 0,7 | 14 | 0,56 |
| 1800 x 1600 | KR10B-500 | 2x 1,0 | 19 | 0,81 |
| 1800 x 1600 | KR10B-400 | 2x 1,0 | 15 | 0,66 |
| 1800 x 1600 | HCV500/800 | 1,4 / 0,7 | 30 | 1,13 |
| 1800 x 1600 | HCV500/600 | 2x 1,4 / 2x 0,7 | 22 | 0,92 |
| 1800 x 1600 | HCV500/350 | 2x 1,4 / 2x 0,7 | 13 | 0,59 |
| 1800 x 1700 | KR10B-500 | 2x 1,0 | 18 | 0,82 |
| 1800 x 1700 | KR10B-400 | 2x 1,0 | 14 | 0,69 |
| 1800 x 1700 | HCV500/800 | 1,4 / 0,7 | 28 | 1,18 |
| 1800 x 1700 | HCV500/600 | 2x 1,4 / 2x 0,7 | 21 | 0,94 |
| 1800 x 1700 | HCV500/350 | 2x 1,4 / 2x 0,7 | 12 | 0,62 |
| 1800 x 1800 | KR10B-500 | 2x 1,0 | 17 | 0,86 |
| 1800 x 1800 | KR10B-400 | 2x 1,0 | 13 | 0,73 |
| 1800 x 1800 | HCV500/1000 | 1,4 / 0,7 | 33 | 1,41 |
| 1800 x 1800 | HCV500/800 | 1,4 / 0,7 | 26 | 1,22 |
| 1800 x 1800 | HCV500/600 | 2x 1,4 / 2x 0,7 | 20 | 0,99 |
| 1800 x 1800 | HCV500/350 | 2x 1,4 / 2x 0,7 | 11 | 0,66 |
| 1800 x 1900 | KR10B-500 | 2x 1,0 | 16 | 0,89 |
| 1800 x 1900 | KR10B-400 | 2x 1,0 | 12 | 0,75 |
| 1800 x 1900 | HCV500/1000 | 1,4 / 0,7 | 31 | 1,49 |

1.2.5.2. technical specification - top- and bottom-opening smoke exhaust windows opening inwards with chain actuators

| WINDOW SIZE** | ACTUATOR* | POWER CONSUMPTION FOR 24 V- / 48 V-*** | OPENING ANGLE | ACTIVE AERODYNAMIC AREA [Aa] |
|---------------|------------|--|---------------|------------------------------|
| B' x H' | | | | |
| [mm] | - | [A] | [°] | [m ²] |
| 1800 x 1900 | HCV500/800 | 1,4 / 0,7 | 25 | 1,27 |
| 1800 x 1900 | HCV500/600 | 2x 1,4 / 2x 0,7 | 19 | 1,03 |
| 1800 x 1900 | HCV500/350 | 2x 1,4 / 2x 0,7 | 11 | 0,67 |
| 1900 x 800 | KR10B-500 | 2x 1,0 | 39 | 0,58 |
| 1900 x 800 | KR10B-400 | 2x 1,0 | 31 | 0,50 |
| 1900 x 800 | HCV500/350 | 2x 1,4 / 2x 0,7 | 27 | 0,44 |
| 1900 x 900 | KR10B-500 | 2x 1,0 | 34 | 0,61 |
| 1900 x 900 | KR10B-400 | 2x 1,0 | 27 | 0,52 |
| 1900 x 900 | HCV500/350 | 2x 1,4 / 2x 0,7 | 24 | 0,46 |
| 1900 x 1000 | KR10B-500 | 2x 1,0 | 31 | 0,65 |
| 1900 x 1000 | KR10B-400 | 2x 1,0 | 24 | 0,53 |
| 1900 x 1000 | HCV500/350 | 2x 1,4 / 2x 0,7 | 21 | 0,47 |
| 1900 x 1100 | KR10B-500 | 2x 1,0 | 28 | 0,68 |
| 1900 x 1100 | KR10B-400 | 2x 1,0 | 22 | 0,56 |
| 1900 x 1100 | HCV500/600 | 2x 1,4 / 2x 0,7 | 33 | 0,78 |
| 1900 x 1100 | HCV500/350 | 2x 1,4 / 2x 0,7 | 19 | 0,49 |
| 1900 x 1200 | KR10B-500 | 2x 1,0 | 25 | 0,71 |
| 1900 x 1200 | KR10B-400 | 2x 1,0 | 20 | 0,59 |
| 1900 x 1200 | HCV500/600 | 2x 1,4 / 2x 0,7 | 30 | 0,83 |
| 1900 x 1200 | HCV500/350 | 2x 1,4 / 2x 0,7 | 17 | 0,52 |
| 1900 x 1300 | KR10B-500 | 2x 1,0 | 23 | 0,75 |
| 1900 x 1300 | KR10B-400 | 2x 1,0 | 19 | 0,62 |
| 1900 x 1300 | HCV500/600 | 2x 1,4 / 2x 0,7 | 28 | 0,86 |
| 1900 x 1300 | HCV500/350 | 2x 1,4 / 2x 0,7 | 16 | 0,54 |
| 1900 x 1400 | KR10B-500 | 2x 1,0 | 21 | 0,78 |
| 1900 x 1400 | KR10B-400 | 2x 1,0 | 17 | 0,64 |
| 1900 x 1400 | HCV500/600 | 2x 1,4 / 2x 0,7 | 26 | 0,89 |
| 1900 x 1400 | HCV500/350 | 2x 1,4 / 2x 0,7 | 15 | 0,56 |
| 1900 x 1500 | KR10B-500 | 2x 1,0 | 20 | 0,80 |
| 1900 x 1500 | KR10B-400 | 2x 1,0 | 16 | 0,66 |
| 1900 x 1500 | HCV500/800 | 1,4 / 0,7 | 32 | 1,14 |
| 1900 x 1500 | HCV500/600 | 2x 1,4 / 2x 0,7 | 24 | 0,91 |
| 1900 x 1500 | HCV500/350 | 2x 1,4 / 2x 0,7 | 14 | 0,58 |
| 1900 x 1600 | KR10B-500 | 2x 1,0 | 19 | 0,83 |
| 1900 x 1600 | KR10B-400 | 2x 1,0 | 15 | 0,69 |
| 1900 x 1600 | HCV500/800 | 1,4 / 0,7 | 30 | 1,20 |
| 1900 x 1600 | HCV500/600 | 2x 1,4 / 2x 0,7 | 22 | 0,96 |
| 1900 x 1600 | HCV500/350 | 2x 1,4 / 2x 0,7 | 13 | 0,61 |
| 1900 x 1700 | KR10B-500 | 2x 1,0 | 18 | 0,87 |
| 1900 x 1700 | KR10B-400 | 2x 1,0 | 14 | 0,73 |
| 1900 x 1700 | HCV500/800 | 1,4 / 0,7 | 28 | 1,25 |
| 1900 x 1700 | HCV500/600 | 2x 1,4 / 2x 0,7 | 21 | 1,00 |
| 1900 x 1700 | HCV500/350 | 2x 1,4 / 2x 0,7 | 12 | 0,65 |
| 1900 x 1800 | KR10B-500 | 2x 1,0 | 17 | 0,90 |

| WINDOW SIZE** | ACTUATOR* | POWER CONSUMPTION FOR 24 V- / 48 V-*** | OPENING ANGLE | ACTIVE AERODYNAMIC AREA [Aa] |
|---------------|-------------|--|---------------|------------------------------|
| B' x H' | | | | |
| [mm] | - | [A] | [°] | [m ²] |
| 1900 x 1800 | KR10B-400 | 2x 1,0 | 13 | 0,75 |
| 1900 x 1800 | HCV500/1000 | 1,4 / 0,7 | 33 | 1,49 |
| 1900 x 1800 | HCV500/800 | 1,4 / 0,7 | 26 | 1,30 |
| 1900 x 1800 | HCV500/600 | 2x 1,4 / 2x 0,7 | 20 | 1,05 |
| 1900 x 1800 | HCV500/350 | 2x 1,4 / 2x 0,7 | 11 | 0,67 |
| 2000 x 800 | KR10B-500 | 2x 1,0 | 39 | 0,61 |
| 2000 x 800 | KR10B-400 | 2x 1,0 | 31 | 0,52 |
| 2000 x 800 | HCV500/350 | 2x 1,4 / 2x 0,7 | 27 | 0,46 |
| 2000 x 900 | KR10B-600 | 2x 1,0 | 42 | 0,72 |
| 2000 x 900 | KR10B-500 | 2x 1,0 | 34 | 0,65 |
| 2000 x 900 | KR10B-400 | 2x 1,0 | 27 | 0,55 |
| 2000 x 900 | HCV500/350 | 2x 1,4 / 2x 0,7 | 24 | 0,49 |
| 2000 x 1000 | KR10B-600 | 2x 1,0 | 37 | 0,77 |
| 2000 x 1000 | KR10B-500 | 2x 1,0 | 31 | 0,69 |
| 2000 x 1000 | KR10B-400 | 2x 1,0 | 24 | 0,56 |
| 2000 x 1000 | HCV500/350 | 2x 1,4 / 2x 0,7 | 21 | 0,50 |
| 2000 x 1100 | KR10B-600 | 2x 1,0 | 33 | 0,82 |
| 2000 x 1100 | KR10B-500 | 2x 1,0 | 28 | 0,72 |
| 2000 x 1100 | KR10B-400 | 2x 1,0 | 22 | 0,59 |
| 2000 x 1100 | HCV500/600 | 2x 1,4 / 2x 0,7 | 33 | 0,81 |
| 2000 x 1100 | HCV500/350 | 2x 1,4 / 2x 0,7 | 19 | 0,52 |
| 2000 x 1200 | KR10B-600 | 2x 1,0 | 30 | 0,88 |
| 2000 x 1200 | KR10B-500 | 2x 1,0 | 25 | 0,75 |
| 2000 x 1200 | KR10B-400 | 2x 1,0 | 20 | 0,62 |
| 2000 x 1200 | HCV500/600 | 2x 1,4 / 2x 0,7 | 30 | 0,87 |
| 2000 x 1200 | HCV500/350 | 2x 1,4 / 2x 0,7 | 17 | 0,55 |
| 2000 x 1300 | KR10B-600 | 2x 1,0 | 28 | 0,89 |
| 2000 x 1300 | KR10B-500 | 2x 1,0 | 23 | 0,77 |
| 2000 x 1300 | KR10B-400 | 2x 1,0 | 19 | 0,63 |
| 2000 x 1300 | HCV500/600 | 2x 1,4 / 2x 0,7 | 28 | 0,89 |
| 2000 x 1300 | HCV500/350 | 2x 1,4 / 2x 0,7 | 16 | 0,56 |
| 2000 x 1400 | KR10B-600 | 2x 1,0 | 26 | 0,93 |
| 2000 x 1400 | KR10B-500 | 2x 1,0 | 21 | 0,80 |
| 2000 x 1400 | KR10B-400 | 2x 1,0 | 17 | 0,66 |
| 2000 x 1400 | HCV500/600 | 2x 1,4 / 2x 0,7 | 26 | 0,92 |
| 2000 x 1400 | HCV500/350 | 2x 1,4 / 2x 0,7 | 15 | 0,58 |
| 2000 x 1500 | KR10B-600 | 2x 1,0 | 24 | 0,97 |
| 2000 x 1500 | KR10B-500 | 2x 1,0 | 20 | 0,84 |
| 2000 x 1500 | KR10B-400 | 2x 1,0 | 16 | 0,69 |
| 2000 x 1500 | HCV500/800 | 2x 1,4 / 2x 0,7 | 32 | 1,20 |
| 2000 x 1500 | HCV500/600 | 2x 1,4 / 2x 0,7 | 24 | 0,96 |
| 2000 x 1500 | HCV500/350 | 2x 1,4 / 2x 0,7 | 14 | 0,61 |
| 2000 x 1600 | KR10B-600 | 2x 1,0 | 22 | 1,01 |
| 2000 x 1600 | KR10B-500 | 2x 1,0 | 19 | 0,88 |

1.2.5.2. technical specification - top- and bottom-opening smoke exhaust windows opening inwards with chain actuators

| WINDOW SIZE** | ACTUATOR* | POWER CONSUMPTION FOR 24 V- / 48 V-*** | OPENING ANGLE | ACTIVE AERODYNAMIC AREA [Aa] |
|---------------|------------|--|---------------|------------------------------|
| B' x H' | | | | |
| [mm] | - | [A] | [°] | [m ²] |
| 2000 x 1600 | KR10B-400 | 2x 1,0 | 15 | 0,73 |
| 2000 x 1600 | HCV500/800 | 2x 1,4 / 2x 0,7 | 30 | 1,27 |
| 2000 x 1600 | HCV500/600 | 2x 1,4 / 2x 0,7 | 22 | 1,01 |
| 2000 x 1600 | HCV500/350 | 2x 1,4 / 2x 0,7 | 13 | 0,65 |
| 2000 x 1700 | KR10B-600 | 2x 1,0 | 21 | 1,06 |
| 2000 x 1700 | KR10B-500 | 2x 1,0 | 18 | 0,91 |
| 2000 x 1700 | KR10B-400 | 2x 1,0 | 14 | 0,75 |
| 2000 x 1700 | HCV500/800 | 2x 1,4 / 2x 0,7 | 28 | 1,32 |
| 2000 x 1700 | HCV500/600 | 2x 1,4 / 2x 0,7 | 21 | 1,06 |
| 2000 x 1700 | HCV500/350 | 2x 1,4 / 2x 0,7 | 12 | 0,67 |
| 2100 x 800 | KR10B-500 | 2x 1,0 | 39 | 0,64 |
| 2100 x 800 | KR10B-400 | 2x 1,0 | 31 | 0,55 |
| 2100 x 800 | HCV500/350 | 2x 1,4 / 2x 0,7 | 27 | 0,49 |
| 2100 x 900 | KR10B-600 | 2x 1,0 | 42 | 0,76 |
| 2100 x 900 | KR10B-500 | 2x 1,0 | 34 | 0,68 |
| 2100 x 900 | KR10B-400 | 2x 1,0 | 27 | 0,58 |
| 2100 x 900 | HCV500/350 | 2x 1,4 / 2x 0,7 | 24 | 0,50 |
| 2100 x 1000 | KR10B-600 | 2x 1,0 | 37 | 0,81 |
| 2100 x 1000 | KR10B-500 | 2x 1,0 | 31 | 0,72 |
| 2100 x 1000 | KR10B-400 | 2x 1,0 | 24 | 0,59 |
| 2100 x 1000 | HCV500/350 | 2x 1,4 / 2x 0,7 | 21 | 0,52 |
| 2100 x 1100 | KR10B-600 | 2x 1,0 | 33 | 0,86 |
| 2100 x 1100 | KR10B-500 | 2x 1,0 | 28 | 0,76 |
| 2100 x 1100 | KR10B-400 | 2x 1,0 | 22 | 0,62 |
| 2100 x 1100 | HCV500/600 | 2x 1,4 / 2x 0,7 | 33 | 0,86 |
| 2100 x 1100 | HCV500/350 | 2x 1,4 / 2x 0,7 | 19 | 0,55 |
| 2100 x 1200 | KR10B-600 | 2x 1,0 | 30 | 0,92 |
| 2100 x 1200 | KR10B-500 | 2x 1,0 | 25 | 0,79 |
| 2100 x 1200 | KR10B-400 | 2x 1,0 | 20 | 0,66 |
| 2100 x 1200 | HCV500/600 | 2x 1,4 / 2x 0,7 | 30 | 0,92 |
| 2100 x 1200 | HCV500/350 | 2x 1,4 / 2x 0,7 | 17 | 0,58 |
| 2100 x 1300 | KR10B-600 | 2x 1,0 | 28 | 0,94 |
| 2100 x 1300 | KR10B-500 | 2x 1,0 | 23 | 0,80 |
| 2100 x 1300 | KR10B-400 | 2x 1,0 | 19 | 0,66 |
| 2100 x 1300 | HCV500/600 | 2x 1,4 / 2x 0,7 | 28 | 0,93 |
| 2100 x 1300 | HCV500/350 | 2x 1,4 / 2x 0,7 | 16 | 0,58 |
| 2100 x 1400 | KR10B-600 | 2x 1,0 | 26 | 0,98 |
| 2100 x 1400 | KR10B-500 | 2x 1,0 | 21 | 0,84 |
| 2100 x 1400 | KR10B-400 | 2x 1,0 | 17 | 0,69 |
| 2100 x 1400 | HCV500/600 | 2x 1,4 / 2x 0,7 | 26 | 0,97 |
| 2100 x 1400 | HCV500/350 | 2x 1,4 / 2x 0,7 | 15 | 0,61 |
| 2100 x 1500 | KR10B-600 | 2x 1,0 | 24 | 1,02 |
| 2100 x 1500 | KR10B-500 | 2x 1,0 | 20 | 0,88 |
| 2100 x 1500 | KR10B-400 | 2x 1,0 | 16 | 0,73 |

| WINDOW SIZE** | ACTUATOR* | POWER CONSUMPTION FOR 24 V- / 48 V-*** | OPENING ANGLE | ACTIVE AERODYNAMIC AREA [Aa] |
|---------------|------------|--|---------------|------------------------------|
| B' x H' | | | | |
| [mm] | - | [A] | [°] | [m ²] |
| 2100 x 1500 | HCV500/800 | 2x 1,4 / 2x 0,7 | 32 | 1,26 |
| 2100 x 1500 | HCV500/600 | 2x 1,4 / 2x 0,7 | 24 | 1,02 |
| 2100 x 1500 | HCV500/350 | 2x 1,4 / 2x 0,7 | 14 | 0,64 |
| 2100 x 1600 | KR10B-600 | 2x 1,0 | 22 | 1,07 |
| 2100 x 1600 | KR10B-500 | 2x 1,0 | 19 | 0,92 |
| 2100 x 1600 | KR10B-400 | 2x 1,0 | 15 | 0,75 |
| 2100 x 1600 | HCV500/800 | 2x 1,4 / 2x 0,7 | 30 | 1,34 |
| 2100 x 1600 | HCV500/600 | 2x 1,4 / 2x 0,7 | 22 | 1,06 |
| 2100 x 1600 | HCV500/350 | 2x 1,4 / 2x 0,7 | 13 | 0,66 |
| 2200 x 800 | KR10B-500 | 2x 1,0 | 39 | 0,66 |
| 2200 x 800 | KR10B-400 | 2x 1,0 | 31 | 0,58 |
| 2200 x 800 | HCV500/350 | 2x 1,4 / 2x 0,7 | 27 | 0,51 |
| 2200 x 900 | KR10B-600 | 2x 1,0 | 42 | 0,80 |
| 2200 x 900 | KR10B-500 | 2x 1,0 | 34 | 0,71 |
| 2200 x 900 | KR10B-400 | 2x 1,0 | 27 | 0,60 |
| 2200 x 900 | HCV500/350 | 2x 1,4 / 2x 0,7 | 24 | 0,52 |
| 2200 x 1000 | KR10B-600 | 2x 1,0 | 37 | 0,85 |
| 2200 x 1000 | KR10B-500 | 2x 1,0 | 31 | 0,76 |
| 2200 x 1000 | KR10B-400 | 2x 1,0 | 24 | 0,62 |
| 2200 x 1000 | HCV500/350 | 2x 1,4 / 2x 0,7 | 21 | 0,55 |
| 2200 x 1100 | KR10B-600 | 2x 1,0 | 33 | 0,90 |
| 2200 x 1100 | KR10B-500 | 2x 1,0 | 28 | 0,80 |
| 2200 x 1100 | KR10B-400 | 2x 1,0 | 22 | 0,66 |
| 2200 x 1100 | HCV500/600 | 2x 1,4 / 2x 0,7 | 33 | 0,90 |
| 2200 x 1100 | HCV500/350 | 2x 1,4 / 2x 0,7 | 19 | 0,58 |
| 2200 x 1200 | KR10B-600 | 2x 1,0 | 30 | 0,94 |
| 2200 x 1200 | KR10B-500 | 2x 1,0 | 25 | 0,81 |
| 2200 x 1200 | KR10B-400 | 2x 1,0 | 20 | 0,67 |
| 2200 x 1200 | HCV500/600 | 2x 1,4 / 2x 0,7 | 30 | 0,94 |
| 2200 x 1200 | HCV500/350 | 2x 1,4 / 2x 0,7 | 17 | 0,59 |
| 2200 x 1300 | KR10B-600 | 2x 1,0 | 28 | 0,98 |
| 2200 x 1300 | KR10B-500 | 2x 1,0 | 23 | 0,84 |
| 2200 x 1300 | KR10B-400 | 2x 1,0 | 19 | 0,70 |
| 2200 x 1300 | HCV500/600 | 2x 1,4 / 2x 0,7 | 28 | 0,98 |
| 2200 x 1300 | HCV500/350 | 2x 1,4 / 2x 0,7 | 16 | 0,61 |
| 2200 x 1400 | KR10B-600 | 2x 1,0 | 26 | 1,03 |
| 2200 x 1400 | KR10B-500 | 2x 1,0 | 21 | 0,88 |
| 2200 x 1400 | KR10B-400 | 2x 1,0 | 17 | 0,73 |
| 2200 x 1400 | HCV500/600 | 2x 1,4 / 2x 0,7 | 26 | 1,02 |
| 2200 x 1400 | HCV500/350 | 2x 1,4 / 2x 0,7 | 15 | 0,64 |
| 2200 x 1500 | KR10B-600 | 2x 1,0 | 24 | 1,07 |
| 2200 x 1500 | KR10B-500 | 2x 1,0 | 20 | 0,93 |
| 2200 x 1500 | KR10B-400 | 2x 1,0 | 16 | 0,77 |
| 2200 x 1500 | HCV500/800 | 2x 1,4 / 2x 0,7 | 32 | 1,32 |

1.2.5.2. technical specification - top- and bottom-opening smoke exhaust windows opening inwards with chain actuators

| WINDOW SIZE** | ACTUATOR* | POWER CONSUMPTION FOR 24 V- / 48 V-*** | OPENING ANGLE | ACTIVE AERODYNAMIC AREA [Aa] |
|---------------|------------|--|---------------|------------------------------|
| B' x H' | | | | |
| [mm] | - | [A] | [°] | [m ²] |
| 2200 x 1500 | HCV500/600 | 2x 1,4 / 2x 0,7 | 24 | 1,07 |
| 2200 x 1500 | HCV500/350 | 2x 1,4 / 2x 0,7 | 14 | 0,68 |
| 2200 x 1600 | KR10B-600 | 2x 1,0 | 22 | 1,11 |
| 2200 x 1600 | KR10B-500 | 2x 1,0 | 19 | 0,97 |
| 2200 x 1600 | KR10B-400 | 2x 1,0 | 15 | 0,79 |
| 2200 x 1600 | HCV500/800 | 2x 1,4 / 2x 0,7 | 30 | 1,37 |
| 2200 x 1600 | HCV500/600 | 2x 1,4 / 2x 0,7 | 22 | 1,11 |
| 2200 x 1600 | HCV500/350 | 2x 1,4 / 2x 0,7 | 13 | 0,70 |
| 2300 x 800 | KR10B-500 | 2x 1,0 | 39 | 0,69 |
| 2300 x 800 | KR10B-400 | 2x 1,0 | 31 | 0,61 |
| 2300 x 800 | HCV500/350 | 2x 1,4 / 2x 0,7 | 27 | 0,54 |
| 2300 x 900 | KR10B-600 | 2x 1,0 | 42 | 0,84 |
| 2300 x 900 | KR10B-500 | 2x 1,0 | 34 | 0,74 |
| 2300 x 900 | KR10B-400 | 2x 1,0 | 27 | 0,62 |
| 2300 x 900 | HCV500/350 | 2x 1,4 / 2x 0,7 | 24 | 0,55 |
| 2300 x 1000 | KR10B-600 | 2x 1,0 | 37 | 0,88 |
| 2300 x 1000 | KR10B-500 | 2x 1,0 | 31 | 0,79 |
| 2300 x 1000 | KR10B-400 | 2x 1,0 | 24 | 0,65 |
| 2300 x 1000 | HCV500/350 | 2x 1,4 / 2x 0,7 | 21 | 0,58 |
| 2300 x 1100 | KR10B-600 | 2x 1,0 | 33 | 0,94 |
| 2300 x 1100 | KR10B-500 | 2x 1,0 | 28 | 0,83 |
| 2300 x 1100 | KR10B-400 | 2x 1,0 | 22 | 0,68 |
| 2300 x 1100 | HCV500/600 | 2x 1,4 / 2x 0,7 | 33 | 0,94 |
| 2300 x 1100 | HCV500/350 | 2x 1,4 / 2x 0,7 | 19 | 0,60 |
| 2300 x 1200 | KR10B-600 | 2x 1,0 | 30 | 0,99 |
| 2300 x 1200 | KR10B-500 | 2x 1,0 | 25 | 0,84 |
| 2300 x 1200 | KR10B-400 | 2x 1,0 | 20 | 0,70 |
| 2300 x 1200 | HCV500/600 | 2x 1,4 / 2x 0,7 | 30 | 0,99 |
| 2300 x 1200 | HCV500/350 | 2x 1,4 / 2x 0,7 | 17 | 0,61 |
| 2300 x 1200 | KR10B-600 | 2x 1,0 | 28 | 1,03 |
| 2300 x 1200 | KR10B-500 | 2x 1,0 | 23 | 0,88 |
| 2300 x 1200 | KR10B-400 | 2x 1,0 | 19 | 0,73 |
| 2300 x 1200 | HCV500/600 | 2x 1,4 / 2x 0,7 | 28 | 1,03 |
| 2300 x 1200 | HCV500/350 | 2x 1,4 / 2x 0,7 | 16 | 0,64 |
| 2300 x 1400 | KR10B-600 | 2x 1,0 | 26 | 1,08 |
| 2300 x 1400 | KR10B-500 | 2x 1,0 | 21 | 0,93 |
| 2300 x 1400 | KR10B-400 | 2x 1,0 | 17 | 0,76 |
| 2300 x 1400 | HCV500/600 | 2x 1,4 / 2x 0,7 | 26 | 1,07 |
| 2300 x 1400 | HCV500/350 | 2x 1,4 / 2x 0,7 | 15 | 0,67 |
| 2300 x 1500 | KR10B-600 | 2x 1,0 | 24 | 1,11 |
| 2300 x 1500 | KR10B-500 | 2x 1,0 | 20 | 0,97 |
| 2300 x 1500 | KR10B-400 | 2x 1,0 | 16 | 0,79 |
| 2300 x 1500 | HCV500/800 | 2x 1,4 / 2x 0,7 | 32 | 1,36 |
| 2300 x 1500 | HCV500/600 | 2x 1,4 / 2x 0,7 | 24 | 1,11 |

| WINDOW SIZE** | ACTUATOR* | POWER CONSUMPTION FOR 24 V- / 48 V-*** | OPENING ANGLE | ACTIVE AERODYNAMIC AREA [Aa] |
|---------------|------------|--|---------------|------------------------------|
| B' x H' | | | | |
| [mm] | - | [A] | [°] | [m ²] |
| 2300 x 1500 | HCV500/350 | 2x 1,4 / 2x 0,7 | 14 | 0,69 |
| 2400 x 800 | KR10B-500 | 2x 1,0 | 39 | 0,72 |
| 2400 x 800 | KR10B-400 | 2x 1,0 | 31 | 0,63 |
| 2400 x 800 | HCV500/350 | 2x 1,4 / 2x 0,7 | 27 | 0,56 |
| 2400 x 900 | KR10B-600 | 2x 1,0 | 42 | 0,88 |
| 2400 x 900 | KR10B-500 | 2x 1,0 | 34 | 0,77 |
| 2400 x 900 | KR10B-400 | 2x 1,0 | 27 | 0,65 |
| 2400 x 900 | HCV500/350 | 2x 1,4 / 2x 0,7 | 24 | 0,57 |
| 2400 x 1000 | KR10B-600 | 2x 1,0 | 37 | 0,92 |
| 2400 x 1000 | KR10B-500 | 2x 1,0 | 31 | 0,83 |
| 2400 x 1000 | KR10B-400 | 2x 1,0 | 24 | 0,68 |
| 2400 x 1000 | HCV500/350 | 2x 1,4 / 2x 0,7 | 21 | 0,60 |
| 2400 x 1100 | KR10B-600 | 2x 1,0 | 33 | 0,97 |
| 2400 x 1100 | KR10B-500 | 2x 1,0 | 28 | 0,85 |
| 2400 x 1100 | KR10B-400 | 2x 1,0 | 22 | 0,69 |
| 2400 x 1100 | HCV500/600 | 2x 1,4 / 2x 0,7 | 33 | 0,97 |
| 2400 x 1100 | HCV500/350 | 2x 1,4 / 2x 0,7 | 19 | 0,61 |
| 2400 x 1200 | KR10B-600 | 2x 1,0 | 30 | 1,03 |
| 2400 x 1200 | KR10B-500 | 2x 1,0 | 25 | 0,88 |
| 2400 x 1200 | KR10B-400 | 2x 1,0 | 20 | 0,73 |
| 2400 x 1200 | HCV500/600 | 2x 1,4 / 2x 0,7 | 30 | 1,03 |
| 2400 x 1200 | HCV500/350 | 2x 1,4 / 2x 0,7 | 17 | 0,64 |
| 2400 x 1300 | KR10B-600 | 2x 1,0 | 28 | 1,08 |
| 2400 x 1300 | KR10B-500 | 2x 1,0 | 23 | 0,92 |
| 2400 x 1300 | KR10B-400 | 2x 1,0 | 19 | 0,76 |
| 2400 x 1300 | HCV500/600 | 2x 1,4 / 2x 0,7 | 28 | 1,08 |
| 2400 x 1300 | HCV500/350 | 2x 1,4 / 2x 0,7 | 16 | 0,67 |
| 2400 x 1400 | KR10B-600 | 2x 1,0 | 26 | 1,11 |
| 2400 x 1400 | KR10B-500 | 2x 1,0 | 21 | 0,97 |
| 2400 x 1400 | KR10B-400 | 2x 1,0 | 17 | 0,80 |
| 2400 x 1400 | HCV500/600 | 2x 1,4 / 2x 0,7 | 26 | 1,10 |
| 2400 x 1400 | HCV500/350 | 2x 1,4 / 2x 0,7 | 15 | 0,70 |
| 2500 x 800 | KR10B-500 | 2x 1,0 | 39 | 0,76 |
| 2500 x 800 | KR10B-400 | 2x 1,0 | 31 | 0,66 |
| 2500 x 800 | HCV500/350 | 2x 1,4 / 2x 0,7 | 27 | 0,59 |
| 2500 x 900 | KR10B-500 | 2x 1,0 | 34 | 0,80 |
| 2500 x 900 | KR10B-400 | 2x 1,0 | 27 | 0,68 |
| 2500 x 900 | HCV500/350 | 2x 1,4 / 2x 0,7 | 24 | 0,60 |
| 2500 x 1000 | KR10B-600 | 2x 1,0 | 37 | 0,96 |
| 2500 x 1000 | KR10B-500 | 2x 1,0 | 31 | 0,86 |
| 2500 x 1000 | KR10B-400 | 2x 1,0 | 24 | 0,71 |
| 2500 x 1000 | HCV500/350 | 2x 1,4 / 2x 0,7 | 21 | 0,63 |
| 2500 x 1100 | KR10B-600 | 2x 1,0 | 33 | 1,01 |
| 2500 x 1100 | KR10B-500 | 2x 1,0 | 28 | 0,88 |

1.2.5.2. technical specification - top- and bottom-opening smoke exhaust windows opening inwards with chain actuators

| WINDOW SIZE** | ACTUATOR* | POWER CONSUMPTION FOR 24 V- / 48 V-*** | OPENING ANGLE | ACTIVE AERODYNAMIC AREA [Aa] |
|---------------|------------|--|---------------|------------------------------|
| B' x H' | | | | |
| [mm] | - | [A] | [°] | [m ²] |
| 2500 x 1100 | KR10B-400 | 2x 1,0 | 22 | 0,72 |
| 2500 x 1100 | HCV500/600 | 2x 1,4 / 2x 0,7 | 33 | 1,01 |
| 2500 x 1100 | HCV500/350 | 2x 1,4 / 2x 0,7 | 19 | 0,64 |
| 2500 x 1200 | KR10B-600 | 2x 1,0 | 30 | 1,08 |
| 2500 x 1200 | KR10B-500 | 2x 1,0 | 25 | 0,92 |
| 2500 x 1200 | KR10B-400 | 2x 1,0 | 20 | 0,76 |
| 2500 x 1200 | HCV500/600 | 2x 1,4 / 2x 0,7 | 30 | 1,08 |
| 2500 x 1200 | HCV500/350 | 2x 1,4 / 2x 0,7 | 17 | 0,66 |
| 2500 x 1300 | KR10B-600 | 2x 1,0 | 28 | 1,13 |
| 2500 x 1300 | KR10B-500 | 2x 1,0 | 23 | 0,96 |
| 2500 x 1300 | KR10B-400 | 2x 1,0 | 19 | 0,80 |
| 2500 x 1300 | HCV500/600 | 2x 1,4 / 2x 0,7 | 28 | 1,12 |
| 2500 x 1300 | HCV500/350 | 2x 1,4 / 2x 0,7 | 16 | 0,70 |
| 2500 x 1400 | KR10B-600 | 2x 1,0 | 26 | 1,14 |
| 2500 x 1400 | KR10B-500 | 2x 1,0 | 21 | 0,98 |
| 2500 x 1400 | KR10B-400 | 2x 1,0 | 17 | 0,81 |
| 2500 x 1400 | HCV500/600 | 2x 1,4 / 2x 0,7 | 26 | 1,14 |
| 2500 x 1400 | HCV500/350 | 2x 1,4 / 2x 0,7 | 15 | 0,72 |
| 2600 x 800 | KR10B-500 | 2x 1,0 | 39 | 0,78 |
| 2600 x 800 | KR10B-400 | 2x 1,0 | 31 | 0,69 |
| 2600 x 800 | HCV500/350 | 2x 1,4 / 2x 0,7 | 27 | 0,61 |
| 2600 x 900 | KR10B-500 | 2x 1,0 | 34 | 0,84 |
| 2600 x 900 | KR10B-400 | 2x 1,0 | 27 | 0,71 |
| 2600 x 900 | HCV500/350 | 2x 1,4 / 2x 0,7 | 24 | 0,62 |
| 2600 x 1000 | KR10B-500 | 2x 1,0 | 31 | 0,90 |
| 2600 x 1000 | KR10B-400 | 2x 1,0 | 24 | 0,74 |
| 2600 x 1000 | HCV500/350 | 2x 1,4 / 2x 0,7 | 21 | 0,65 |
| 2600 x 1100 | KR10B-500 | 2x 1,0 | 28 | 0,92 |
| 2600 x 1100 | KR10B-400 | 2x 1,0 | 22 | 0,75 |
| 2600 x 1100 | HCV500/600 | 2x 1,4 / 2x 0,7 | 33 | 1,05 |
| 2600 x 1100 | HCV500/350 | 2x 1,4 / 2x 0,7 | 19 | 0,66 |
| 2600 x 1200 | KR10B-600 | 2x 1,0 | 30 | 1,12 |
| 2600 x 1200 | KR10B-500 | 2x 1,0 | 25 | 0,96 |
| 2600 x 1200 | KR10B-400 | 2x 1,0 | 20 | 0,79 |
| 2600 x 1200 | HCV500/600 | 2x 1,4 / 2x 0,7 | 30 | 1,12 |
| 2600 x 1200 | HCV500/350 | 2x 1,4 / 2x 0,7 | 17 | 0,69 |
| 2600 x 1300 | KR10B-600 | 2x 1,0 | 28 | 1,17 |
| 2600 x 1300 | KR10B-500 | 2x 1,0 | 23 | 1,01 |
| 2600 x 1300 | KR10B-400 | 2x 1,0 | 19 | 0,83 |
| 2600 x 1300 | HCV500/600 | 2x 1,4 / 2x 0,7 | 28 | 1,17 |
| 2600 x 1300 | HCV500/350 | 2x 1,4 / 2x 0,7 | 16 | 0,73 |
| 2700 x 800 | KR10B-500 | 2x 1,0 | 39 | 0,81 |
| 2700 x 800 | KR10B-400 | 2x 1,0 | 31 | 0,71 |
| 2700 x 800 | HCV500/350 | 2x 1,4 / 2x 0,7 | 27 | 0,63 |

| WINDOW SIZE** | ACTUATOR* | POWER CONSUMPTION FOR 24 V- / 48 V-*** | OPENING ANGLE | ACTIVE AERODYNAMIC AREA [Aa] |
|---------------|------------|--|---------------|------------------------------|
| B' x H' | | | | |
| [mm] | - | [A] | [°] | [m ²] |
| 2700 x 900 | KR10B-500 | 2x 1,0 | 34 | 0,87 |
| 2700 x 900 | KR10B-400 | 2x 1,0 | 27 | 0,74 |
| 2700 x 900 | HCV500/350 | 2x 1,4 / 2x 0,7 | 24 | 0,65 |
| 2700 x 1000 | KR10B-500 | 2x 1,0 | 31 | 0,94 |
| 2700 x 1000 | KR10B-400 | 2x 1,0 | 24 | 0,77 |
| 2700 x 1000 | HCV500/350 | 2x 1,4 / 2x 0,7 | 21 | 0,68 |
| 2700 x 1100 | KR10B-500 | 2x 1,0 | 28 | 0,96 |
| 2700 x 1100 | KR10B-400 | 2x 1,0 | 22 | 0,78 |
| 2700 x 1100 | HCV500/600 | 2x 1,4 / 2x 0,7 | 33 | 1,10 |
| 2700 x 1100 | HCV500/350 | 2x 1,4 / 2x 0,7 | 19 | 0,69 |
| 2700 x 1200 | KR10B-600 | 2x 1,0 | 30 | 1,17 |
| 2700 x 1200 | KR10B-500 | 2x 1,0 | 25 | 1,00 |
| 2700 x 1200 | KR10B-400 | 2x 1,0 | 20 | 0,83 |
| 2700 x 1200 | HCV500/600 | 2x 1,4 / 2x 0,7 | 30 | 1,17 |
| 2700 x 1200 | HCV500/350 | 2x 1,4 / 2x 0,7 | 17 | 0,72 |
| 2700 x 1300 | KR10B-600 | 2x 1,0 | 28 | 1,19 |
| 2700 x 1300 | KR10B-500 | 2x 1,0 | 23 | 1,02 |
| 2700 x 1300 | KR10B-400 | 2x 1,0 | 19 | 0,84 |
| 2700 x 1300 | HCV500/600 | 2x 1,4 / 2x 0,7 | 28 | 1,19 |
| 2700 x 1300 | HCV500/350 | 2x 1,4 / 2x 0,7 | 16 | 0,74 |

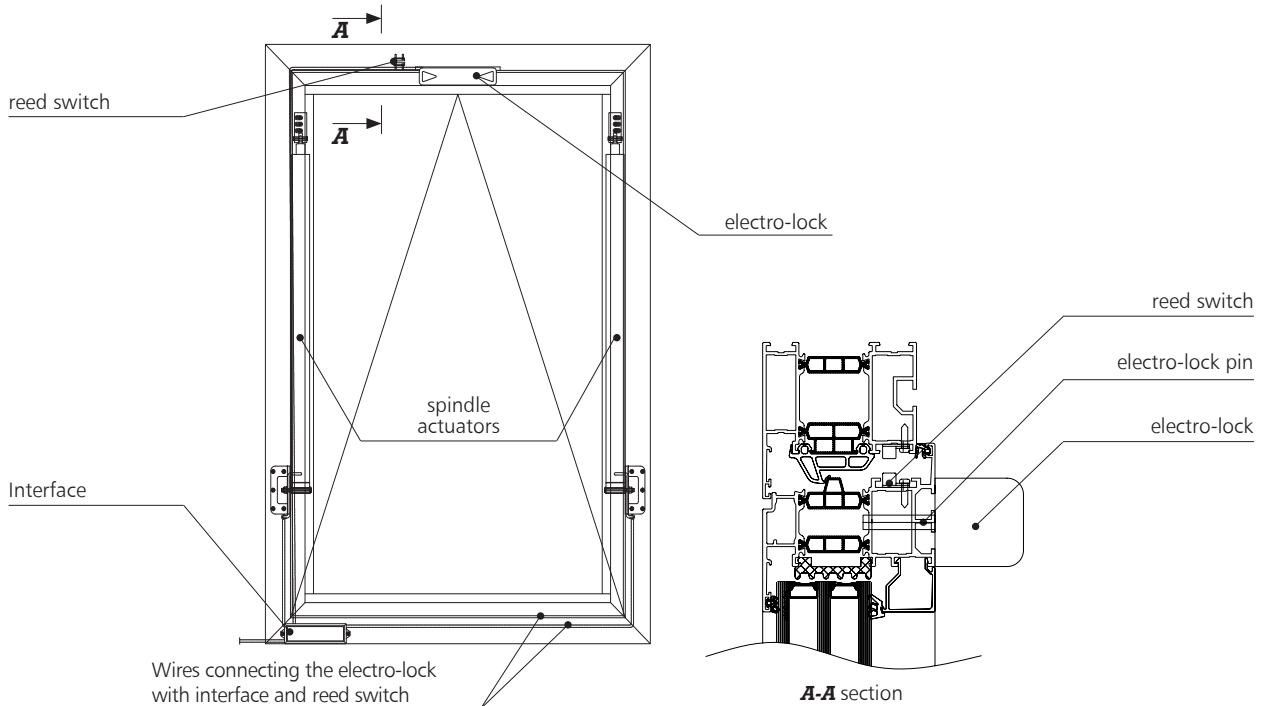
(*) Actuators of type HCV 500/xxx may be supplied with 24V- or 48V-. HCV 500/xxx actuator with voltage 230V~ and power consumption 0.13A may be used as an equivalent of each specified HCV 500/xxx actuator. KR10B actuators are supplied with 24V-.

(**) It is possible to make intermediate dimensions of the smoke exhaust window between the values given in the table. The size of the active aerodynamic area for these dimensions is determined by linear interpolation.

(***) Power consumption given for the list of actuators used in a given smoke exhaust window.

1.2.6. technical specification - application of electro-lock in windows with spindle actuators

The automatic electro-lock for smoke and air exhaust windows provides protection and safety. It is mounted in place of the handle, where after receiving 24 V voltage it rotates and moves the peripheral hardware. This guarantees resistance of the leaf against wind load and suitable, tamper-proof leaf-to-frame connection. The electro-lock works with the: interface, reed switch and the actuators. Standard peripheral hardware is used for installation. Electro-lock specification: 24 V-; 1.0 A; 10 Nm.



| | | H' - window height [mm] | | | | | | | | | | | | | | |
|------------------------|------|-------------------------|-----|------|------|------|------|------|------|------|------|------|------|------|------|------|
| | | 800 | 900 | 1000 | 1100 | 1200 | 1300 | 1400 | 1500 | 1600 | 1700 | 1800 | 1900 | 2000 | 2100 | 2200 |
| B' - window width [mm] | 800 | • | • | • | • | • | • | • | • | • | • | • | • | • | • | • |
| | 900 | • | • | • | • | • | • | • | • | • | • | • | • | • | • | • |
| | 1000 | • | • | • | • | • | • | • | • | • | • | • | • | • | • | • |
| | 1100 | • | • | • | • | • | • | • | • | • | • | • | • | • | • | • |
| | 1200 | • | • | • | • | • | • | • | • | • | • | • | • | • | • | • |
| | 1300 | • | • | • | • | • | • | • | • | • | • | • | • | • | • | • |
| | 1400 | • | • | • | • | • | • | • | • | • | • | • | • | • | • | • |
| | 1500 | • | • | • | • | • | • | • | • | • | • | • | • | • | • | • |
| | 1600 | • | • | • | • | • | • | • | • | • | • | • | • | • | • | • |
| | 1700 | • | • | • | • | • | • | • | • | • | • | • | • | • | • | • |
| | 1800 | • | • | • | • | • | • | • | • | • | • | • | • | • | • | • |
| | 1900 | • | • | • | • | • | • | • | • | • | • | • | • | • | • | • |
| | 2000 | • | • | • | • | • | • | • | • | • | • | • | • | • | • | • |
| | 2100 | • | • | • | • | • | • | • | • | • | • | • | • | • | • | • |
| | 2200 | • | • | • | • | • | • | • | • | • | • | • | • | • | • | • |
| | 2300 | • | • | • | • | • | • | • | • | • | • | • | • | • | • | • |
| | 2400 | • | • | • | • | • | • | • | • | • | • | • | • | • | • | • |
| 2500 | • | • | • | • | • | • | • | • | • | • | • | • | • | • | • | |
| 2600 | • | • | • | • | • | • | • | • | • | • | • | • | • | • | • | |
| 2700 | • | • | • | • | • | • | • | • | • | • | • | • | • | • | • | |

- dimensional range of electro-lock windows
- dimensional range of windows without electro-lock
- area beyond availability

2. smoke exhaust window control system

Electrically controlled natural smoke exhausting systems are usually designed in staircases of low and medium-rise buildings and in other escape routes, such as office aisles, or passages and atria in shopping malls.

Smoke exhaust windows can be triggered manually, e.g. by pressing the emergency pushbutton, automatically through smoke detectors or remotely through the smoke detection system. In such case, the system starts to operate in the initial phase of the fire, improving the evacuation conditions for the users of the facility, and with more extensive control systems it is also possible to change the smoke exhaust scenario as the fire conditions change.

A frequent addition to the smoke exhaust window control system are switches for manual activation of daily ventilation. The daily ventilation system may be equipped with a weather monitoring unit with a wind-rain sensor. In case of adverse weather conditions wind and rain sensor automatically closes the windows opened for daily ventilation.

ELECTRIC SPINDLE ACTUATORS

Fig. 107 - Spindle actuator type S



Fig. 108 - Spindle actuator type G

ELECTRIC CHAIN ACTUATORS

Fig. 109 - Chain actuator type KR10B



Fig. 110 - Chain actuator type HCV, HCVA

2.1. 24 V- spindle electric actuators

24 V- electric spindle motors are used to open smoke exhaust windows as well as for daily ventilation. They are powered by 24 V-. The actuator casing is made of anodized aluminium. They are equipped as standard with an anti-interference capacitor, overload switch and reed switches. Protection grade IP40 for type G actuators, operating mode S2 (according to DIN EN 0530), available options IP42, IP54 and IP42 for type S actuators.

2.1.1. type G spindle electric actuators

| ACTUATOR TYPE | SUPPLY VOLTAGE | NOMINAL POWER CONSUMPTION | ACTUATOR STROKE | DIMENSIONS (LxBxH) | MAXIMUM OPERATING TEMPERATURE |
|---------------|----------------|---------------------------|-----------------|--------------------|-------------------------------|
| | [V] | [A] | [mm] | [mm] | [°C] |
| G26G/H-550 | 24 | 2,6 | 550 | 839 x 58 x 47 | -25 ÷ +60 |
| G26G/H-600 | 24 | 2,6 | 600 | 889 x 58 x 47 | -25 ÷ +60 |
| G26G/H-750 | 24 | 2,6 | 750 | 1039 x 58 x 47 | -25 ÷ +60 |
| G40H-830 | 24 | 4,0 | 830 | 1119 x 58 x 47 | -25 ÷ +60 |

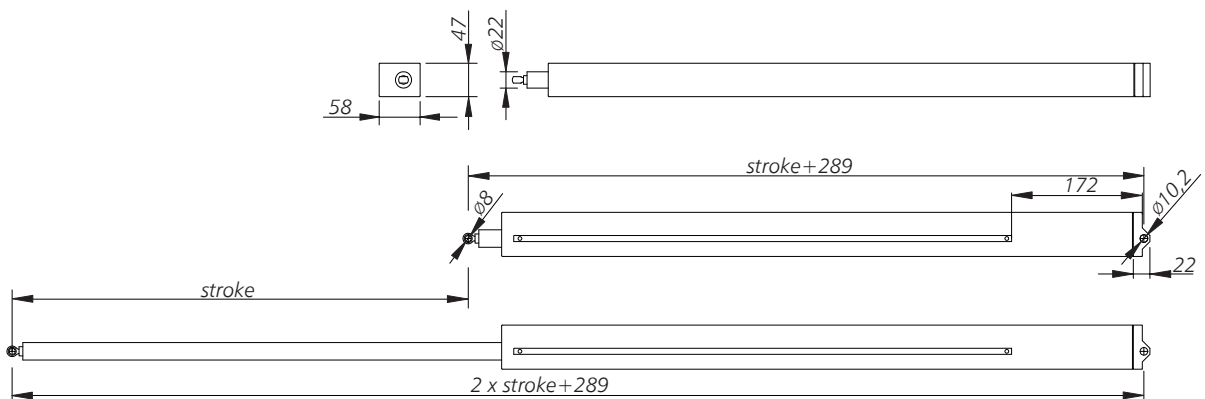


Fig. 111 - Dimensions of type G electric spindle actuator [mm]

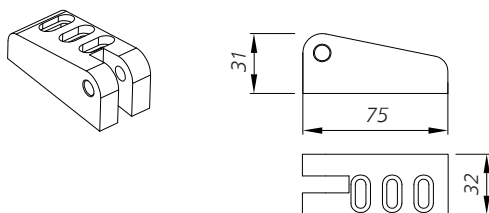


Fig. 112 - Top console for mounting type G spindle actuator on the smoke exhaust window, dimensions [mm]

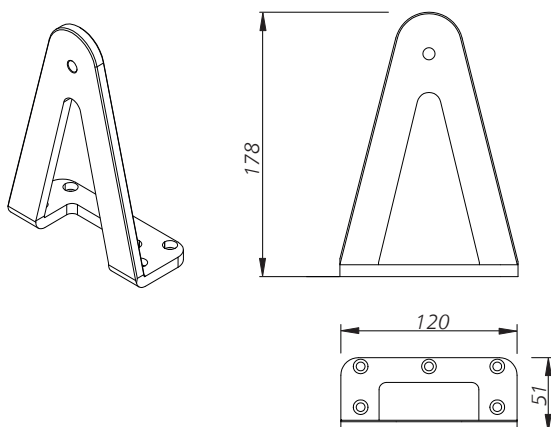


Fig. 113 - Bottom bracket for mounting type G spindle actuator on the smoke exhaust window, dimensions [mm]

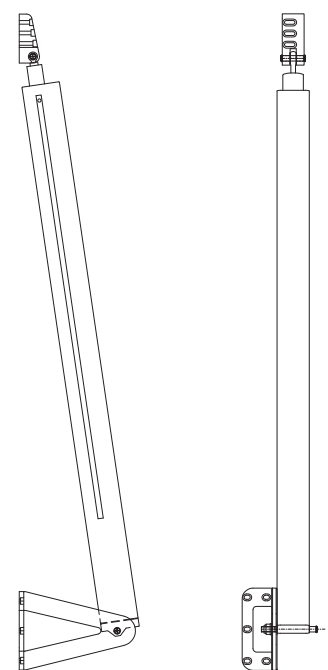


Fig. 114 - Type G spindle actuator with upper and lower console mounted

2.1.1. type G spindle electric actuator with shifted pivot point

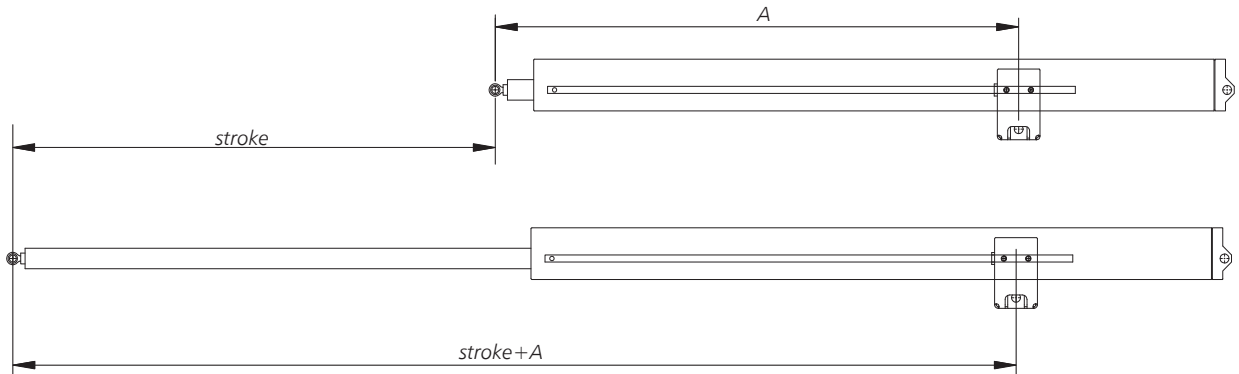


Fig. 115 - Dimensions of type G spindle actuator with shifted pivot point

A - dimension depends on opening angle and height of the window

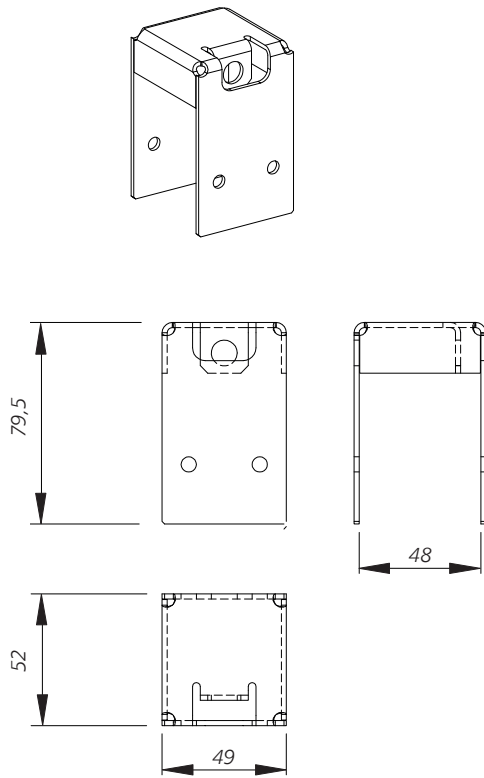


Fig. 116 - Sliding console for mounting type G spindle actuator with shifted pivot point on the smoke exhaust window, dimensions [mm]

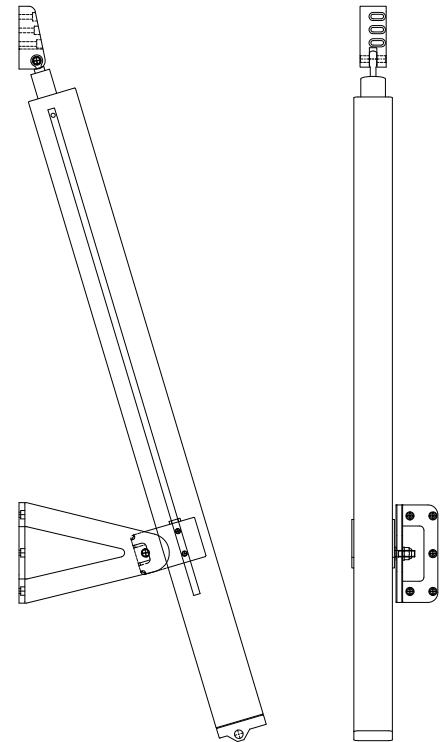


Fig. 117 - Type G spindle actuator with upper and lower console mounted with shifted pivot point

2.1.2. type S spindle electric actuators

| ACTUATOR TYPE | SUPPLY VOLTAGE | NOMINAL POWER CONSUMPTION | ACTUATOR STROKE | DIMENSIONS (LxØ) | MAXIMUM OPERATING TEMPERATURE |
|---------------|----------------|---------------------------|-----------------|------------------|-------------------------------|
| | [V] | [A] | [mm] | [mm] | [°C] |
| S08B-200 | 24 | 0,8 | 200 | 452 x 36 | -25 ÷ +60 |
| S08B-300 | 24 | 0,8 | 300 | 552 x 36 | -25 ÷ +60 |
| S10C-350 | 24 | 1,0 | 350 | 602 x 36 | -25 ÷ +60 |
| S10C-400 | 24 | 1,0 | 400 | 652 x 36 | -25 ÷ +60 |
| S10C-450 | 24 | 1,0 | 450 | 702 x 36 | -25 ÷ +60 |

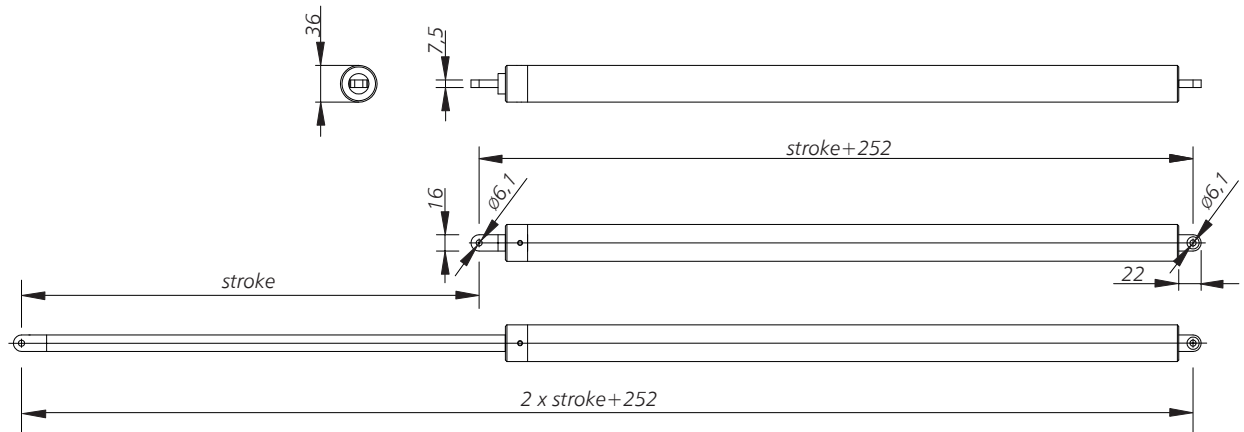


Fig. 118 - Dimensions of type S electric spindle actuator [mm]

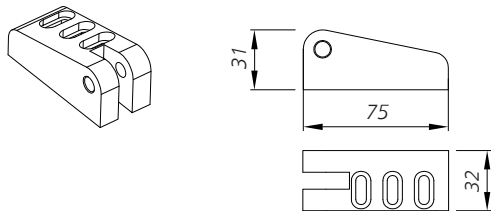


Fig. 119 - Top console for mounting type S spindle actuator on the smoke exhaust window, dimensions [mm]

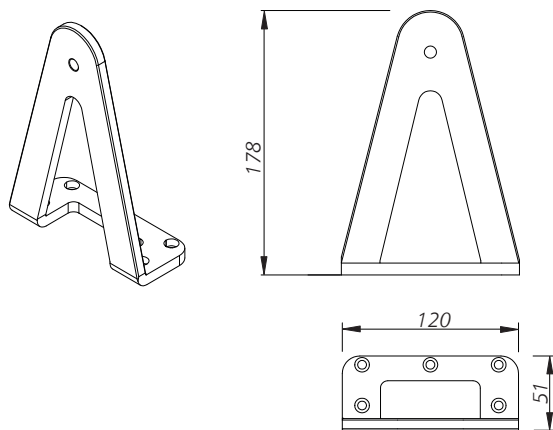


Fig. 120 - Bottom bracket for mounting type S spindle actuator on the smoke exhaust window, dimensions [mm]

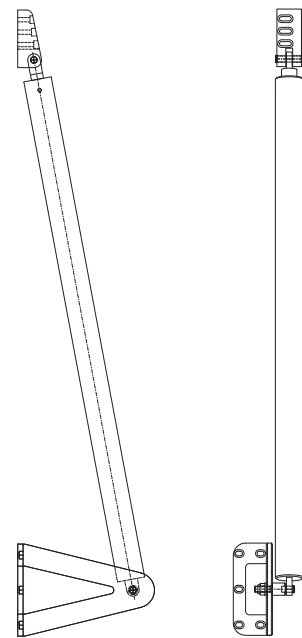


Fig. 121 - Type S spindle actuator with upper and lower console mounted

2.1.2. type S spindle electric actuator with shifted pivot point

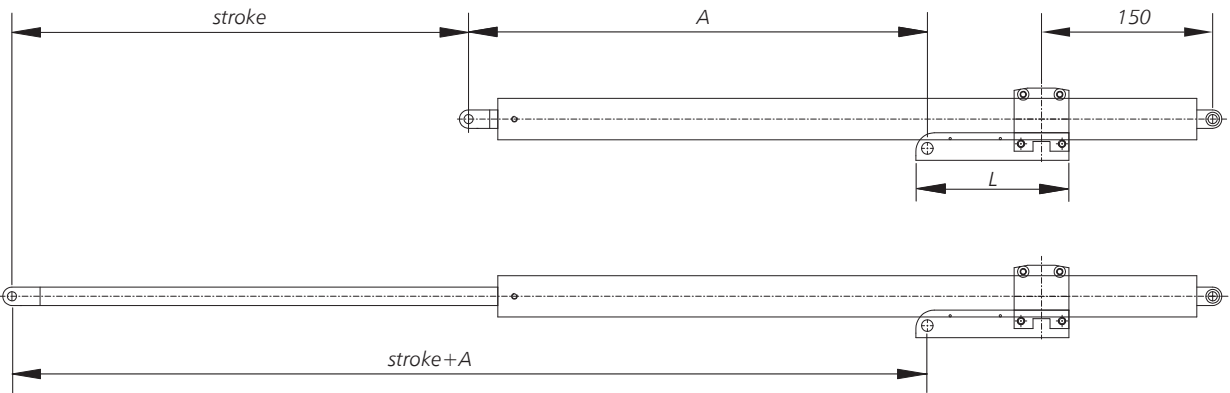


Fig. 122 - Dimensions of type S spindle electric actuator with shifted pivot point [mm]

A, L - dimensions depends on opening angle and window height

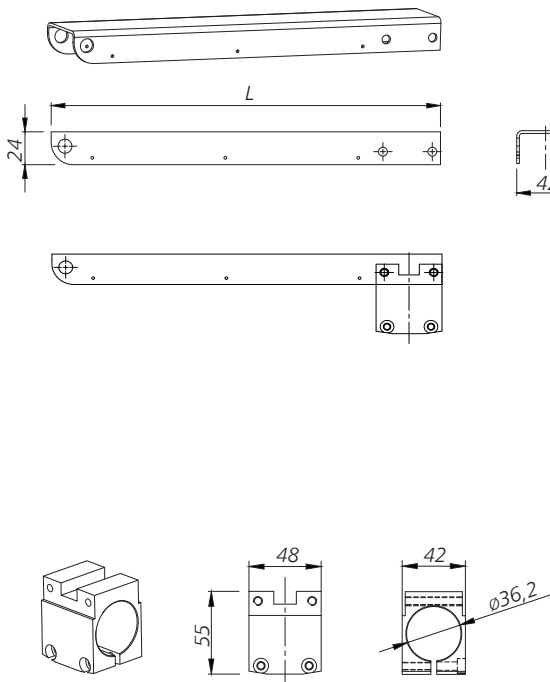


Fig. 123 - Sliding console for mounting type S spindle actuator with shifted pivot point on the smoke exhaust window, dimensions [mm]

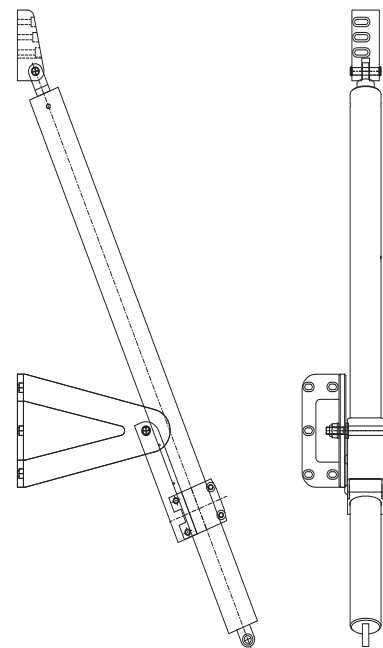


Fig. 124 - Type S spindle actuator with upper and lower console mounted with shifted pivot point

2.2. 24 V- / 48 V- electric chain actuators

24 V- or 48 V- electric chain actuators are used for opening smoke exhaust windows as well as for daily ventilation. They are supplied with 24 V- or 48 V- DC. The actuator casing is made of anodized aluminium. They are equipped as standard with an anti-interference capacitor, overload switch and reed switches. IP20 protection grade.

2.2.1. type KR10B electric chain actuator

| ACTUATOR TYPE | SUPPLY VOLTAGE | NOMINAL POWER CONSUMPTION | ACTUATOR STROKE | DIMENSIONS (LxBxH) | MAXIMUM OPERATING TEMPERATURE |
|---------------|----------------|---------------------------|-----------------|--------------------|-------------------------------|
| | [V] | [A] | [mm] | [mm] | [°C] |
| KR10B | 24 | 1,0 | 400 | 594 x 47 x 35 | -20 ÷ +60 |
| KR10B | 24 | 1,0 | 500 | 694 x 47 x 35 | -20 ÷ +60 |
| KR10B | 24 | 1,0 | 600 | 794 x 47 x 35 | -20 ÷ +60 |

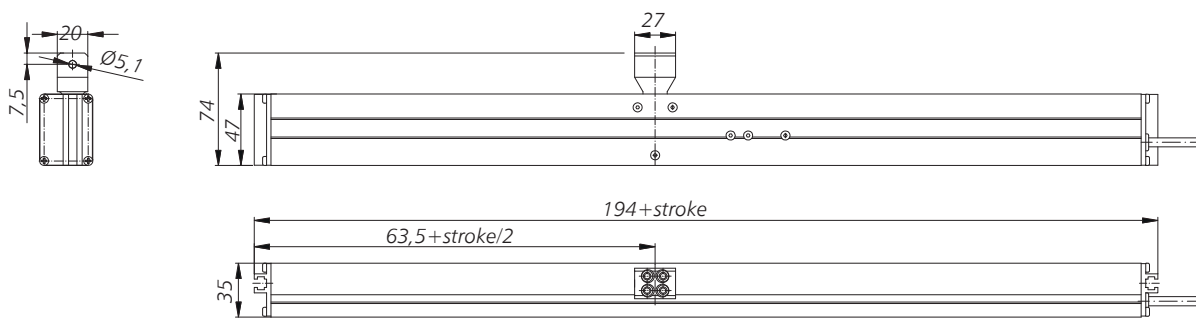


Fig. 125 - Dimensions of KR10B electric chain actuator [mm]



Fig. 126 - KR10B chain actuator with consoles for outward opening window



Fig. 127 - KR10B chain actuator with consoles for inward opening window

2.2.2. HCV electric chain actuator (24 V- / 48 V-)

Electric chain drive in a stylish, anodised aluminium casing. The push/pull force of the actuators is 500 N / 500 N. Maximum holding force 2000 N. Full load speed up to 10 mm/sec; speed at nominal load up to 17 mm/sec (depending on chain length). Two different speeds can be set: for daily ventilation and for the smoke exhausting function. Electronically controlled cut-off in end position and emergency stop on overload. Heat-resistant 2.5 m long silicone connection cable. IP32 protection grade.

| ACTUATOR TYPE | SUPPLY VOLTAGE | NOMINAL POWER CONSUMPTION | ACTUATOR STROKE | DIMENSIONS (LxBxH) | MAXIMUM OPERATING TEMPERATURE |
|---------------|----------------|---------------------------|-----------------|--------------------|-------------------------------|
| | [V] | [A] | [mm] | [mm] | [°C] |
| HCV 500/350 | 24 | 1,4 | 350 | 436 x 51 x 40 | -25 ÷ +75 |
| | 48 | 0,7 | | | |
| HCV 500/600 | 24 | 1,4 | 600 | 561 x 51 x 40 | -25 ÷ +75 |
| | 48 | 0,7 | | | |
| HCV 500/800 | 24 | 1,4 | 800 | 661 x 51 x 40 | -25 ÷ +75 |
| | 48 | 0,7 | | | |
| HCV 500/1000 | 24 | 1,4 | 1000 | 766 x 51 x 40 | -25 ÷ +75 |
| | 48 | 0,7 | | | |

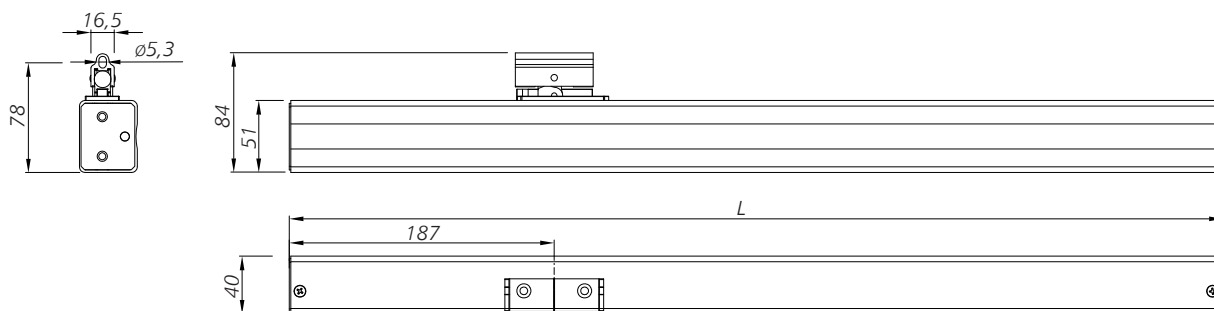


Fig. 128 - Dimensions of HCV electric chain actuator [mm]



Fig. 129 - HCV chain actuator with consoles for outward opening window



Fig. 130 - HCV chain actuator with consoles for inward opening window

2.3. HCVA electric chain actuators (~230 V-)

Electric chain drive in a stylish, anodised aluminium casing. The push/pull force of the actuators is 500 N / 500 N. Maximum holding force 2000 N. Full load speed up to 10 mm/s (depending on chain length). Electronically controlled cut-off in end position and emergency stop on overload. Heat-resistant 2.5 m long silicone connection cable. IP32 protection grade.

| ACTUATOR TYPE | SUPPLY VOLTAGE | NOMINAL POWER CONSUMPTION | ACTUATOR STROKE | DIMENSIONS (LxBxH) | MAXIMUM OPERATING TEMPERATURE |
|---------------|----------------|---------------------------|-----------------|--------------------|-------------------------------|
| | [V] | [W] | [mm] | [mm] | [°C] |
| HCVA 500/350 | 230 | 30 | 350 | 586 x 51 x 40 | -5 ÷ +55 |
| HCVA 500/600 | 230 | 30 | 600 | 711 x 51 x 40 | -5 ÷ +55 |
| HCVA 500/800 | 230 | 30 | 800 | 811 x 51 x 40 | -5 ÷ +55 |
| HCVA 500/1000 | 230 | 30 | 1000 | 916 x 51 x 40 | -5 ÷ +55 |

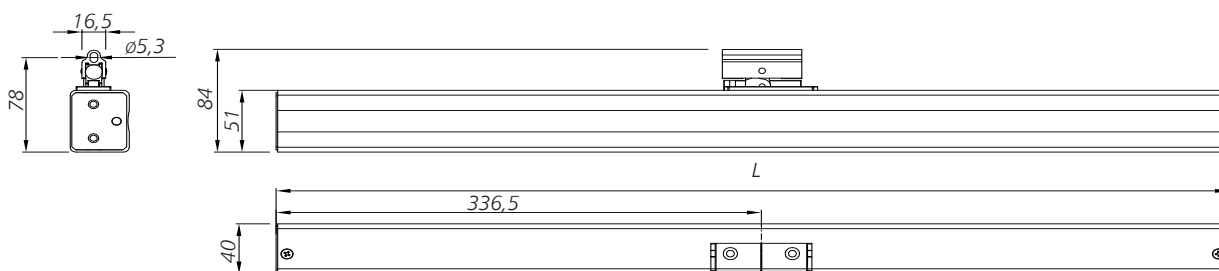


Fig. 131 - Dimensions of HCVA electric chain actuator [mm]



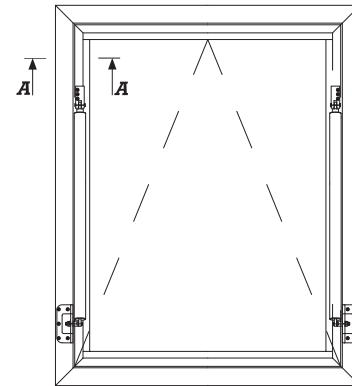
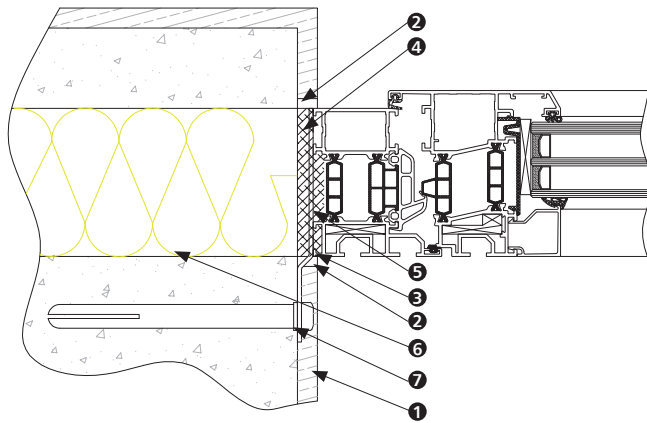
Fig. 132 - HCVA chain actuator with consoles for outward opening window



Fig. 133 - HCVA chain actuator with consoles for inward opening window

3. smoke exhaust window installation

3.1. smoke exhaust window mounted in a three-layer wall

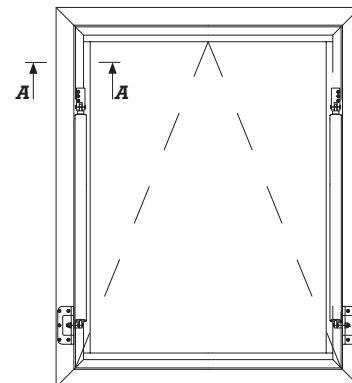
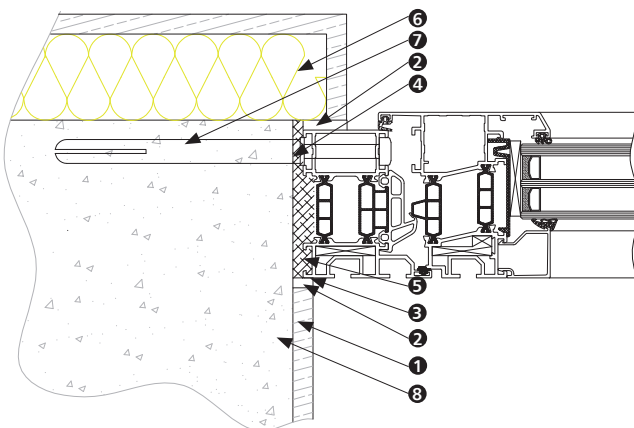


1 - plaster
2 - sealing tape, expandable
3 - interface insulation
(neutral silicone)

4 - polyurethane sealing foam
5 - installation gap (10 - 30 mm)
6 - thermal insulation

7 - mounting anchor / dowel

3.2. wall-mounted smoke exhaust window with external insulation

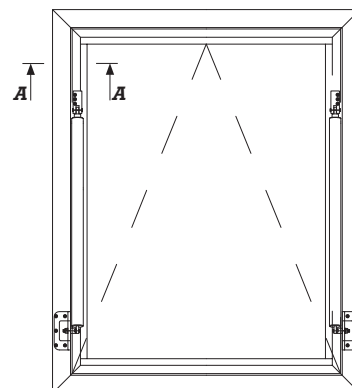
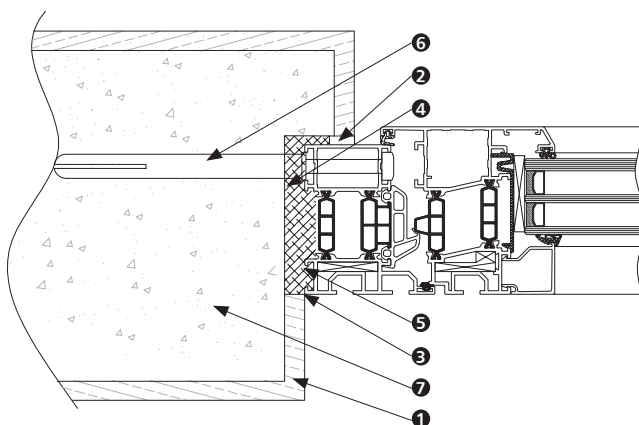


1 - plaster
2 - sealing tape, expandable
3 - interface insulation
(neutral silicone)

4 - polyurethane sealing foam
5 - installation gap (10 - 30 mm)
6 - thermal insulation

7 - dowel
8 - bearing wall

3.3. smoke exhaust window mounted in the wall with external reveal



1 - plaster
2 - sealing tape, expandable
3 - interface insulation
(neutral silicone)

4 - polyurethane sealing foam
5 - installation gap (10 - 30 mm)
6 - dowel

7 - bearing wall

3.4. connection of inward- or outward-opening smoke exhaust window with facade

